

## Worldwide Sumitomo Network

### U.S.A.

Sumitomo Machinery Corporation of America  
4200 Holland Blvd.  
Chesapeake, VA 23323  
U.S.A.  
Tel: (1)757-485-3355  
Fax: (1)757-487-3193

### Canada

SM-Cydo of Canada, Ltd.  
Via dell' Artigianato 231-20010  
870 Equestrian Court Oakville  
Ontario, Canada L6L 6L7  
Tel: (1)905-469-1050  
Fax: (1)905-469-1055

### Mexico

SM-Cydo De Mexico, S.A. de C.V.  
Calle "C" No. 506A Parque Industrial  
Almacentro Apodaca, N. L., Mexico 66600  
Tel: (52)81-8369-3697  
Fax: (52)81-8369-3699

### Brazil

SM-Cydo Redutores Do Brasil Ltda.  
Av. Fagundes Filho, 191 Metro Sao Judas  
Edificio Houston-Sala H123 Sao Paulo-SP  
Brazil 04304-010  
Tel: (55)11-5585-3600  
Fax: (55)11-5585-9990

### Chile

SM-Cydo De Chile, Ltda.  
San Pablo Ave, 3507 Quinta Noma,  
Santiago, Chile  
Tel: (56)2-786-6963  
Fax: (56)2-786-6964

### Argentina

SM-Cydo De Argentina S.A.  
Montes de Oca #6719, (B1606BMG) Munro,  
Buenos Aires, Argentina  
Tel: (54)11-4765-5288  
Fax: (54)11-4765-5517

### United Kingdom

SM-Cydo U.K. Ltd.  
Marfleet, Kingston Upon Hull HU9 5RA,  
United Kingdom  
Tel: (44)1482-790340  
Fax: (44)1482-790321

### France

SM-Cydo France E.U.R.L.  
65775 Avenue Jean Mermoz  
F-93126 La Courmeuve France  
Tel: (33)149-929494  
Fax: (33)149-929490

### Italy

SM-Cydo Italy Srl  
Via dell' Artigianato 231-20010  
Cornaredo (MI), Italy  
Tel: (39)02-9356-2121  
Fax: (39)02-9356-9893

### Netherlands

SM-Cydo Benelux BV  
Den Engelsman 16D NL-6026 RB  
Maarheeze The Netherlands  
Tel: (31)495599777  
Fax: (31)495593177

### Sweden

SM-Cydo Scandinavia AB  
Företagsvägen 30A S-232 37  
Ärlöv Sweden  
Tel: (46)40430220  
Fax: (46)40431001

### Spain

SM-Cydo Iberia,S.L.  
C/Landabarrí N°4 Escalera 1, 2ª Izqda Leioa  
48940 Vizcaya Spain  
Tel: (34)944-805 389  
Fax: (34)944-801 550

### Germany

Sumitomo (SHI) Cydo Drive Germany, GmbH  
Cyclostraße 92  
D-85229 Markt Indersdorf  
Germany  
Tel: (49)8136-66-0  
Fax: (49)8136-5771

### Austria

SCG Branch Austria Office  
Gruentalerstraße, 30A A-4028 Linz, Austria  
Tel: (43)732-330 958  
Fax: (43)732-331 978

### China

Sumitomo (SHI) Cydo Drive China, Ltd.  
26F, Raffles City No.268, Xizang  
Road Central, Shanghai 200001 China  
Tel: (86)21-6340-4000  
Fax: (86)21-6340-3673

### Hong Kong

SM-Cydo of Hong Kong Co., Ltd.  
Unit 1802, 18/F, Park Building, 476  
Castle Peak Road, Kowloon, Hong Kong  
Tel: (852)2460-1881  
Fax: (852)2460-1882

### Singapore

Sumitomo (SHI) Cydo Drive Asia Pacific Pte. Ltd.  
No.36 Tuas South Street 3,  
Singapore 638031  
Tel: (65)6863-2238  
Fax: (65)6863-4238

### Malaysia

SM-Cydo of (Malaysia) Sdn. Bhd.  
No.2, Jalan BP 4/1,  
Bandar Bukit Puchong, 47100 Puchong,  
Selangor Darul Ehsan, Malaysia  
Tel: (60)3-8061-2909  
Fax: (60)3-8061-3909

### Thailand

SM-Cydo (Thailand) Co., Ltd.  
195, Empire Tower  
Unit 1504, 15th Floor  
South Sathorn Road, Yannawa Sathorn  
Bangkok 10120, Thailand  
Tel: (66)2-670-0998  
Fax: (66)2-670-0999

### Vietnam

Sumitomo (SHI) Cydo-Drive Asia Pacific Pte. Ltd.  
Representative Office in Hochi Minh City  
Floor 4, 99 Nguyen Thi Minh Khai Street  
World Ben Thanh, District 1, HCM City, Vietnam  
Tel: (84)8-925-6504  
Fax: (84)8-925-6505

### Australia

SM-Cydo (Australia) Pty., Ltd.  
9 HolbecheRd, Arndell Park, NSW, 2148  
Australia  
Postal: PO Box 319 Doonside NSW, 2767  
Tel: (61)2-8811-6555  
Fax: (61)2-8811-6500  
National Telephone Number: 1 3000 DRIVE

### Philippines

Sumitomo (SHI) Cydo Drive Asia Pacific Pte. Ltd.  
Representative Office in Philippines  
Unit 23E Burgundy Corporate Tower  
252 Sen. Gil Puyat Ave. Makati City, Philippines  
Tel: (63)2-888-5866  
Fax: (63)2-843-0021

### India

Sumi-Cydo India Pet. Ltd.  
759/17, Ramkripa Apartment, Flat No.2,  
First Floor Capt. A. Ranade Path,  
Deccan Gymkhana, Pune 411004.  
Maharashtra, India  
Tel: (91)202-5653760  
Fax: (91)202-5653755

### Taiwan

Tatung SM-Cydo Co., Ltd.  
22 Chungshan N. Road  
3rd., Sec. Taipei, Taiwan, 104 R.O.C.  
Tel: (886)2-2595-7275  
Fax: (886)2-2595-5594

### Korea

Sumitomo (SHI) Cydo Drive Korea Ltd.  
Royal Bldg. 9F Rm. 913,  
5 Dangju-dong Chongro-ku,  
Seoul, Korea 110-721  
Tel: (82)2-730-0151  
Fax: (82)2-730-0156

### Japan

Sumitomo Heavy Industries, Ltd.  
ThinkPark Tower 1-1, Osaki 2-Chome  
Shinagawa-ku, Tokyo 141-6025,  
Japan  
Tel: (81)3-6737-2511  
Fax: (81)3-6866-5160

# Sumitomo Drive Technologies

*Always on the Move*

# ALTAX<sup>®</sup> NEO

CW15



## Introducing ALTAX<sup>®</sup> NEO

ALTAX NEO Series, a new addition to the ALTAX line of gearmotors that have established a strong reputation since its launch in 1993.

While maintaining the compactness of the ALTAX<sub>α</sub> series, ALTAX NEO has adopted the both-side supported mechanism that holds the cycloid disc, the core component of Cyclo Speed Reducer, from both sides. The models with a brake also feature a low-noise brake.

The series caters to a broad range of applications as a compact and low-noise gearmotor.



### CYCLO<sup>®</sup> Speed Reducer

Unlike an involute-tooth gear, Cyclo Speed Reducer is an internal planetary-gearing reducer that features the cycloid disc, which has a unique smooth tooth profile (epitrochoidal parallel curve).

The internal gear also has teeth of a distinctive circular-arc profile, which enables smooth rotation. The reducer mechanism is made of Chromium bearing steel, which offers excellent abrasion resistance and fatigue resistance.

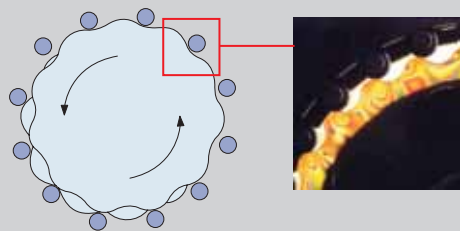

#### CYCLO<sup>®</sup> SPEED REDUCER

All torque transmitting parts roll, not grind.

The gear tooth profile of the Cyclo<sup>®</sup> reducer enables the sharing of the load by a number of teeth, thus not susceptible to tooth breakage.

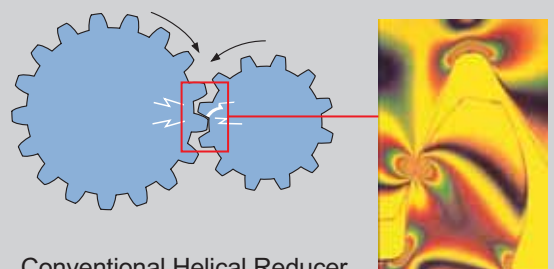

#### Conventional Helical Reducer

Involute gears allow for small tooth engagement rate.

Torque transmitting parts grind, wear, and can break off with the sliding contact.

## 1. Low Noise

### Both-Side Supported Mechanism<sup>\*1</sup>

Supporting the cycloid disc and other reducer mechanism from both sides

### Traction Drive<sup>\*2</sup>

Quiet operation without noise from teeth meshing

### High Tooth-Count and High Tooth Contact

Significantly increased number of teeth mesh simultaneously

### Low Noise Brake<sup>\*3</sup>

Low-noise brake is now the standard instead of being optional.

\*1: Models with frame sizes which do not end with "R" or "S."  
 \*2: Models with frame sizes ending with "R" or "S."  
 \*3: Excluding 90W and 2.2kW inverter motors.

## 2. Compactness

### Compact Design

Major installation dimensions are compatible with ALTAX  $\alpha$  models, which is reputed for their compactness.

### Smallest Flange in the Industry

ALTAX NEO has a concentric shaft structure unlike a regular gearmotor. This is to achieve the industry's smallest flange size. The flange and the motor is concentric for a compact design.

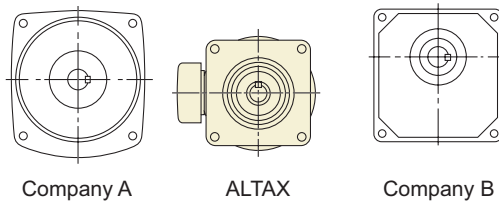

Company A

ALTAX

Company B

## 3. Usability

### Universal Mounting Direction

There are no limits in installation direction for all models. Users have the freedom of design to suit application.

### Maintenance-Free

All models are grease-lubricated, eliminating the need for maintenance for a long time. Our unit are shipped with grease packed for immediate use.

## 4. Wide Variety

ALTAX NEO offers a wide variation of motors. Users can choose an exact unit to match their needs. They also comply to standards in various countries.

Three-phase motor  
 Single-phase motor  
 Motor for inverter  
 Motor with brake  
 High-efficiency motor

Outdoor motor  
 Increased safety type motor  
 Special voltage motor  
 Overseas specifications motor



CSA Standard



EC Directive



UL Certification



CCC

## Table of Contents

	Page
Nomenclature .....	3
List of Models .....	3
Standard Specification .....	4
Model Selection .....	5
Reference for Model Selection .....	6
Notes for Selecting a Traction Model .....	8
Selection Tables and Dimension Tables	
Three-Phase Motor .....	
90W .....	9
0.1kW .....	10
0.2kW .....	11
0.25kW .....	12
0.4kW .....	13
0.55kW .....	14
0.75kW .....	15
1.1kW .....	16
1.5kW .....	17
2.2kW .....	18
Single-Phase Motor	
90 W .....	19
0.1kW .....	20
0.2kW .....	21
0.4kW .....	22
Three-Phase Motor for Inverter	
0.1kW .....	23
0.2kW .....	24
0.4kW .....	25
0.75kW .....	26
1.5kW .....	27
2.2kW .....	28
Technical Data	
Moment of Inertia J-GD <sup>2</sup> .....	29
Slow Speed Shaft Direction .....	30
Actual Reduction Ratio .....	30
Lubrication .....	30
Characteristics of Global Motor .....	31
Characteristics of Brakes .....	33
Connection .....	35
Standard Paint Properties .....	36
Color .....	36
Warranty Standard .....	38
Safety Precautions .....	38

### Both-Side Supported Structure

Patent No. 02888674

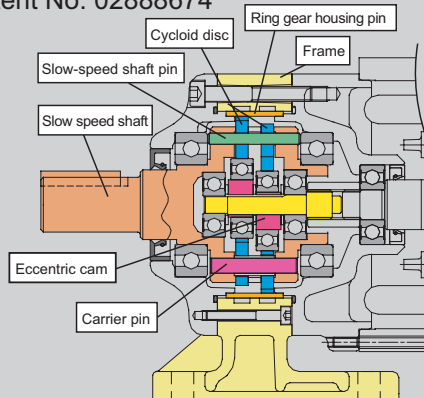

### High Tooth-Count and High Tooth Contact Gear

Patent No. 02639847

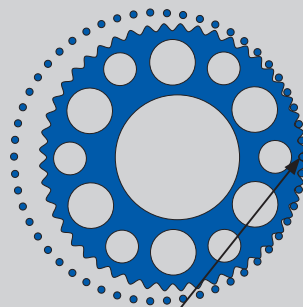

Large number of teeth come in contact simultaneously

### Traction Drive

Patent Pending



The models with the frame size ending with "R" or "S" use traction drive for the planetary mechanism.

### Noise Reduction

The Mechanism enables quieter operation than regular gearmotors without contact noise. (Up to 5dB (A) lower than our gearmotors of the equivalent size)





# Standard Specification

## Standard Specifications

### ALTAX NEO Three-Phase / Single-Phase Gearmotor

Type	Item	Standard Specification	Standard Specification with Built-in Brake	
Motor Part	Three-Phase Motor	Capacity Range	Note: 90W - 2.2kW, 4-pole	Note: 90W - 2.2kW, 4-pole RB, FB brake (non-asbestos lining)
		Enclosure	IP44 (indoor), totally-enclosed fan-cooled type (The 90W and 0.1kW models are the totally-closed self-cooled type)	IP44 (indoor), totally-enclosed fan-cooled type (The 90W and 0.1kW models are the totally-closed self-cooled type)
		Power Source	Three-rated power sources 200V 50/60Hz, 220V 60Hz or 400V 50/60Hz, 440V 60Hz	Three-rated power source 200V 50/60Hz, 220V 60Hz or 400V 50/60Hz, 440V 60Hz
		Insulation	90W - 0.4kW 4-pole: E 0.55 - 2.2kW 4-pole: B	90W - 0.4kW 4-pole: E (B for brake) 0.55 - 2.2kW 4-pole: B (B for brake)
		Time Rating	Continuous rating	Continuous rating
		Starting System	Direct connection	Direct connection
		Leading Wiring (Lug Type)	90W - 2.2kW 4-pole: 3 cables	90W - 2.2kW 4-pole: 5 cables
		Standard	JIS compliant	JIS compliant
	Single-Phase Motor		Induction	Induction
		Capacity Range	Note: 90W - 0.4 kW, 4-pole	Note: 90W - 0.4 kW, 4-pole RB, FB brake (non-asbestos lining)
		Enclosure	IP44 (indoor), totally-enclosed fan-cooled type	IP44 (indoor), totally-enclosed fan-cooled type
		Power Source	100V, 200V 50/60Hz (dual voltage) 100V 50/60Hz for 90W	100V, 200V 50/60Hz (dual voltage) 100V 50/60Hz for 90W
		Insulation	90W 4-pole: E 0.1 - 0.4kW 4-pole: B	90W 4-pole: E (B for the brake) 0.1 - 0.4kW 4-pole: B (B for the brake)
		Time Rating	Continuous rating	Continuous rating
		Starting System	90W 4-pole: Capacitor-run 0.1 - 0.4kW 4 pole: Capacitor-start / Capacitor-run	90W 4-pole: Capacitor-run 0.1 - 0.4kW 4 pole: Capacitor-start / Capacitor-run
		Leading Wiring (Lug Type)	90W 4-pole: 3 cables 0.1 - 0.4kW 4-pole: 6 cables	90W 4-pole: 5 cables 0.1 - 0.4kW 4-pole: 8 cables
	Standard	JIS compliant	JIS compliant	
	Motor for Inverter	Capacity Range	Note: 0.1 - 2.2kW, 4-pole	Note: 0.1 - 2.2kW, 4-pole FB brake (non-asbestos lining)
		Enclosure	IP44 (indoor), totally-enclosed fan-cooled type	IP44 (indoor), totally-enclosed fan-cooled type
		Power Source	200V 60Hz, 220V 60Hz	200V 60Hz, 220V 60Hz
		Insulation	B (6 - 60Hz fixed torque)	B (B for the brake)
		Time Rating	Continuous rating (6 - 60Hz fixed torque)	Continuous rating (6 - 60Hz fixed torque)
		Leading Wiring (Lug Type)	0.1 - 2.2kW 4-pole: 3 cables	0.1 - 2.2kW 4-pole: 5 cables
		Standard	JIS compliant	JIS compliant
	Gear Part	Lubrication Method	Grease lubricated (filled with grease at factory shipment)	
		Material	Casing: Aluminum alloy (Cast iron for the frame size 5117, 5117DR, 5127, 5127DA, 5127DR, and 5127DS)	
	Ambient Conditions	Installation Location	Indoor (minimal dust and humidity)	
		Ambient Temperature	-10 ~ +40°C	
Ambient Humidity		Nomore than 85% with no condensation		
Altitude		No more than 1,000m		
Atmosphere		Well-ventilated location, free of corrosive gas, explosive gas, vapors, and dust		
Installation Angle		Universal (No restriction)		
Painting		Paint type: Acrylic urethane Paint color: (Munsell 5Y8/1 or equivalent)		

Note: ASTERO Gearmotor is used for the parallel shaft of three-phase or single-phase motor up to 60W (6 - 60W).

Refer to the specific catalog for details.

# Model Selection

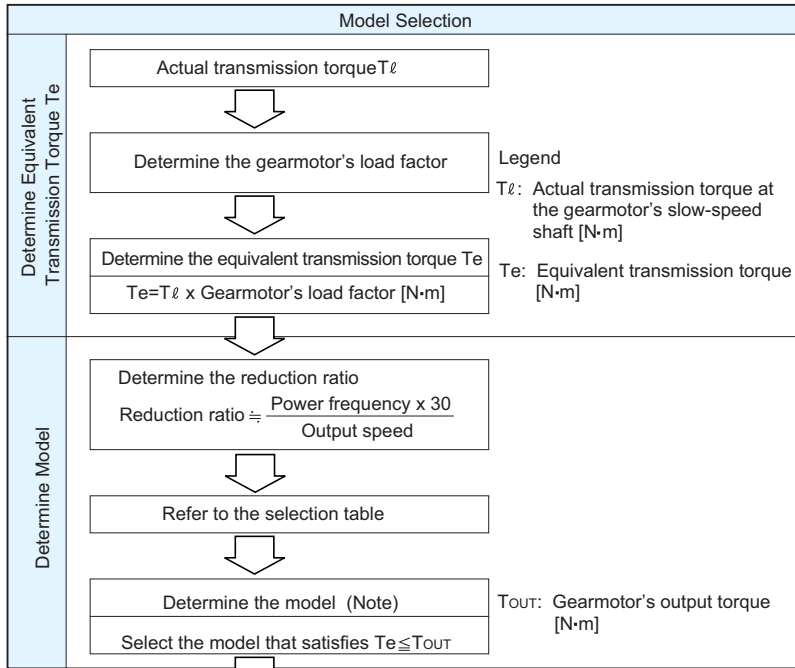

Note: Models with "R" or "S" at the end of the nomenclature are the traction drive type. Make sure to read page 8 for cautions on traction drive types.

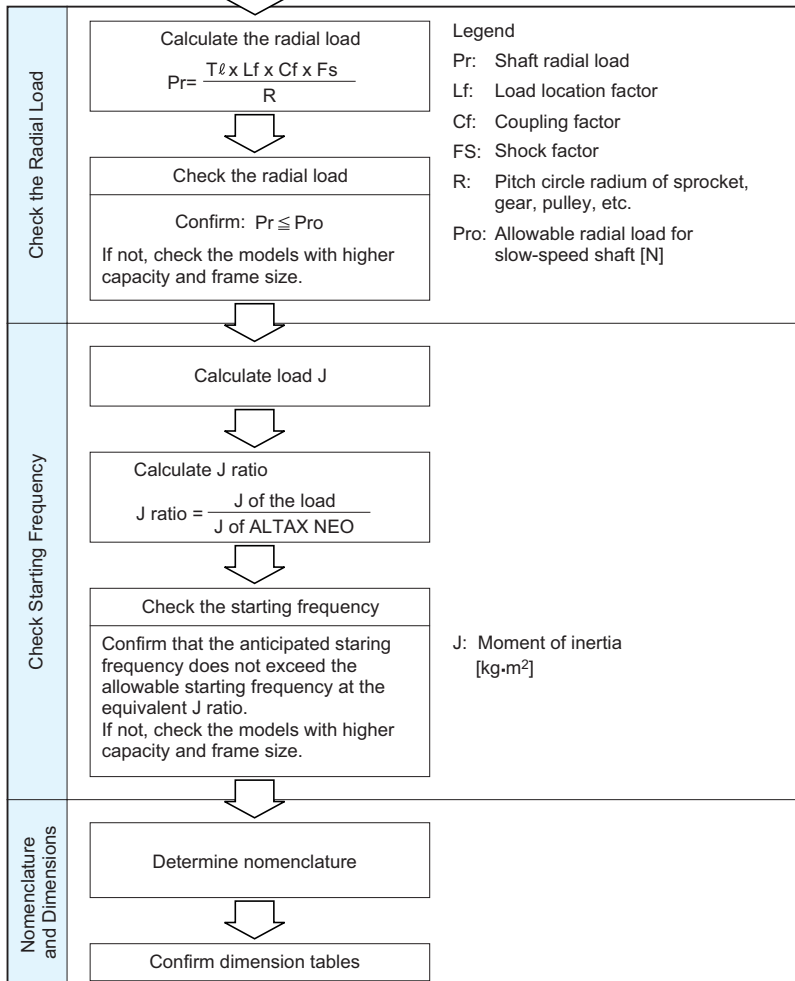

# Reference for Model Selection

ALTAX NEO gearmotor is designed for 10 hours operation per day with uniform load.

## 1. Gearmotor's Load Factor

Table 1

Daily Duty Load Condition	Up to 10 Hours per Day	10 - 24 Hours per Day	Main Applications
Uniform Load	1	1.2	Conveyor (uniform load), pump (centrifugal), food processing machine (rice milling machine, can filling machine), elevator (uniform load), plastic molding machine, agitator (liquid), bar screen
Light Shock Load	1.2	1.35	Conveyor (heavy duty, not uniformly fed), food processing machine (beet slicer, dough mixer, meat grinder), elevator (heavy load), agitator (liquids & solids, liquids variable density), feeder (belt, apron, screw), thickener, flocculater, general tools (for main shaft)
Heavy Shock Load	1.5	1.6	Punching press, tapping machine, crusher mill, hoist (heavy load), barking drum, log haul, cutter, plater

## 2. Shaft Radial Load

When attaching ALTAX NEO gearmotor to a chain wheel or pulley, make sure of the radial load of the shaft. The radial load must be smaller than the allowable radial load for slow-speed shaft. Calculate radial load by the following formula.

$$\text{Shaft radial load } P_r = \frac{T_\ell \times L_f \times C_f \times F_s}{R} \text{ [N]}$$

$T_\ell$ : Actual transmission torque at ALTAX NEO's slow-speed shaft [N·m]

$L_f$ : Load location factor

$C_f$ : Coupling factor

$F_s$ : Shock factor

$R$ : Pitch circle radius of sprocket, gear, pulley, etc. [m]

Table 2: Load Location Factor  $L_f$

Load Location	$L_f$
Shaft Base	0.8
Shaft Center	1.0
Shaft End	1.4

Table 3: Coupling Factor  $C_f$

Coupling Method	$C_f$
Chain	1
Gear	1.25
V-belt	1.5

Table 4: Shock Factor  $F_s$

Degree of Shock	$F_s$
Practically No Shock	1
Light Shock	1~1.2
Severe Shock	1.4~1.6

## 3. Allowable Starting Frequency

Large load moment of inertia generates a large torque momentarily at the time of starting (or when stopping for models with brake). Keep the starting frequency within the allowable range as shown below. It is determined according to the coupling method and the size of inertia involved. Also check the motor's allowable thermal capacity on page 7.

Table 5: Allowable Starting Frequency

J: Moment of Inertia

Coupling with the Load	J ratio $\left( \frac{\text{Motor-shaft Equivalent Load } J}{\text{Motor Equivalent ALTAX NEO } J} \right)$	Allowable Starting Frequency
Direct Coupling with No Play	2	5 times per hour
	1.5	Once per minute
	0.6 and smaller	10 times per minute
Chain Coupling with Play	1	5 times per hour
	0.75	Once per minute
	0.4 and smaller	7 times per minute

Note: For a short period of time, the gearmotor may be used at more than the allowable frequency. Consult us for confirmation.

# Reference for Model Selection

Table 6: Motor's Allowable Thermal Capacity (C x Z)

Motor Output [kW]	Allowable C x Z				Motor's Moment of Inertia [kg·m <sup>2</sup> ]		Motor GD <sup>2</sup> [kgf·m <sup>2</sup> ]	
	(Up to 35%ED)	(Over 35%ED - up to 50%ED)	(Over 50%ED - up to 80%ED)	(Over 80%ED - up to 100%ED)	Standard	With Brake	Standard	With Brake
0.1	3200	3000	2000	1200	0.00033	0.00035	0.0013	0.0014
0.2	2200	2800	2800	2500	0.00050	0.00055	0.002	0.0022
0.25	2200	2800	2800	2500	0.00050	0.00055	0.002	0.0022
0.4	1800	2200	1500	1500	0.00065	0.00068	0.0026	0.0027
0.55	1800	2200	1500	1500	0.00101	0.00111	0.00405	0.00445
0.75	1400	1400	800	500	0.00120	0.00130	0.0048	0.0052
1.1	1400	1400	800	500	0.00185	0.00208	0.0074	0.0083
1.5	1200	1200	500	400	0.00213	0.00235	0.0085	0.0094
2.2	1000	900	400	200	0.00333	0.00373	0.0133	0.0149
3.0	1000	900	400	200	0.00700	0.00810	0.0281	0.0325
3.7	800	800	800	700	0.00848	0.00958	0.0339	0.0383
5.5	300	300	200	150	0.01143	0.01253	0.0457	0.0501

Calculate C x Z by below steps (1)-(3). The value must be less than allowable C x Z listed in Table 6.

(1) Calculate C using formula below.

$$\text{SI units } C = \frac{J_M + J_L}{J_M}$$

$$\text{Gravitational units } C = \frac{GD_M^2 + GD_L^2}{GD_M^2}$$

J<sub>M</sub>: Moment of inertia of motor [kg·m<sup>2</sup>]

GD<sub>M</sub><sup>2</sup>: GD<sup>2</sup> of motor [kgf·m<sup>2</sup>]

J<sub>L</sub>: Total moment of inertia (excluding motor) at motor shaft [kg·m<sup>2</sup>]

GD<sub>L</sub><sup>2</sup>: Total GD<sup>2</sup> (excluding motor) at motor shaft [kgf·m<sup>2</sup>]

(2) Calculate Z (number of starting times/hour)

(a) Operating period consists of "operation time t<sub>a</sub> [sec]" and "stop time t<sub>b</sub> [sec]." Motor is started with speed n<sub>r</sub> [times/cycle] in this period.

$$Z_r = \frac{3600n_r}{t_a + t_b} \quad [\text{times/hr}]$$

(b) Be careful inching [times/cycle] per each cycle (t<sub>a</sub> + t<sub>b</sub>). Make sure to convert inching per hour (Z<sub>i</sub>) into number of starting per hour.

$$Z_i = \frac{3600n_i}{t_a + t_b} \quad [\text{times/hr}]$$

(c) Calculate Z [times/hr] from (a) and (b).

$$Z = Z_r + \frac{1}{2} Z_i = \frac{3600}{t_a + t_b} \cdot \left( n_r + \frac{1}{2} n_i \right) \quad [\text{times/hr}]$$

(3) Calculate C multiplied by Z.

Use the C obtained in step (1) and Z in step (2).

(4) Obtain the duty cycle %ED. Check with table above.

$$\%ED = \frac{t_a}{t_a + t_b} \times 100$$



# Notes for Selecting a Traction Model

## Notes for Selecting a Traction Model

The models that have "R" or "S" at the end of the frame size (for example, 507R, 5107DR, and 5127DS) are traction-drive models. They are suitable for normal applications, but consult us for confirmation for the following applications:

### (1) Load and Application

Consult us for applications involving particularly severe impact load (crushers, breakers, high-speed cutting machines) or variable load (crank/cam motions).

### (2) Applications Requiring High-Precision Positioning

Actual reduction ratio of traction-drive models fluctuates slightly, depending to the operation and load condition.

Actual reduction ratio = Nominal reduction ratio x (0.997 to 1.003)

Consult us for applications requiring high-precision positioning (for example, printers, labelers, automation devices, and elevators).

Be especially careful when combining the both support type (gear without motor) with a servo motor.

# Gearmotors, Flange Mount Type (CNVM), Foot Mount Type (CNHM) 90W Three-Phase Motor

## Selection Tables

Reduction Ratio	Output Speed		Input Capacity Symbol	Frame Size	Reduction Ratio	Output Torque Tout				Allowable Radial Load Pro				Dimension Table No.				
	r/min					N·m		kg·m		N		kgf		CNVM	CNHM			
	50Hz	60Hz				50Hz	60Hz	50Hz	60Hz	50Hz	60Hz	50Hz	60Hz					
Nomenclature details: p. 3																		
6	242	292	009	-	5067	(-B)	-	6	3.38	2.80	0.344	0.285	540	540	55.0	55.0	V1	H1
8	181	219	009	-	5067	(-B)	-	8	4.50	3.73	0.459	0.380	687	687	70.0	70.0		
11	132	159	009	-	5067	(-B)	-	11	6.19	5.13	0.631	0.523	687	687	70.0	70.0		
13	112	135	009	-	5067	(-B)	-	13	7.32	6.07	0.746	0.618	687	687	70.0	70.0		
15	96.7	117	009	-	5067	(-B)	-	15	8.45	7.00	0.861	0.713	883	883	90.0	90.0		
17	85.3	103	009	-	5067	(-B)	-	17	9.57	7.93	0.976	0.809	883	883	90.0	90.0		
21	69.0	83.3	009	-	5067	(-B)	-	21	11.8	9.80	1.21	0.999	1180	1180	120	120		
25	58.0	70.0	009	-	5067	(-B)	-	25	14.1	11.7	1.44	1.19	1180	1180	120	120		
29	50.0	60.3	009	-	5067	(-B)	-	29	16.3	13.5	1.66	1.38	1230	1230	125	125		
35	41.4	50.0	009	-	5067	(-B)	-	35	19.7	16.3	2.01	1.66	1230	1230	125	125		
43	33.7	40.7	009	-	5067	(-B)	-	43	24.2	20.1	2.47	2.05	1230	1230	125	125		
51	28.4	34.3	009	-	5067	(-B)	-	51	28.7	23.8	2.93	2.43	1230	1230	125	125		

- Note: 1. Output motor speed is the representative value at 1450r/min (50Hz) and 1750r/min (60Hz). Refer to page 31 for details.  
 2. Radial load at slow speed shaft is the value at the middle of the slow speed shaft.  
 3. Figure in the bracket ( ) shows the dimension for types with brake.  
 4. Outdoor type, dustproof type with brake, and some type for special power source or overseas specification are combined with motor, capacity 0.1kW, frame size of 506H.

## Dimension Tables

Figure in the bracket ( ) shows the dimension for types with brake.

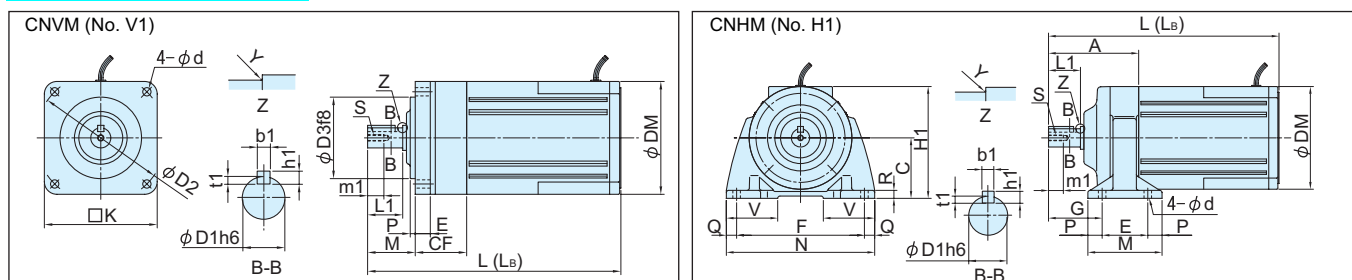

No.	Model	Main Body										Motor		Slow-speed Shaft Unit							Mass	
		CF	d	E	L	(L <sub>b</sub> )	M	P	D2	D3	K	J	DM	L1	m1	S	Y	D1	b1	h1	t1	kg
V1	CNVM009-5067(-B)-Reduction Ratio	41	6.6	12	202	261	38	4	104	65	90	-	90	28	13	M5	0.5	16	5	5	3	4 (4.5)

No.	Model	Main Body												Motor		Slow-speed Shaft Unit							Mass				
		A	C	d	E	F	G	H1	L	(L <sub>b</sub> )	M	N	P	Q	R	V	J	DM	L1	m1	S	Y	D1	b1	h1	t1	kg
H1	CNHM009-5067(-B)-Reduction Ratio	79	53	6.6	40	112	47	98	202	261	65	130	12.5	9	7	45	-	90	28	13	M5	0.5	16	5	5	3	4 (4.5)

# Gearmotors, Flange Mount Type (CNVM), Foot Mount Type (CNHM) 0.1kW Three-Phase Motor

## Selection Tables

Reduction Ratio	Output Speed		Input Capacity Symbol	Frame Size	Reduction Ratio	Output Torque Tout				Allowable Radial Load Pro				Dimension Table No.		
	r/min					N·m		kg·m		N		kgf		CNVM	CNHM	
	50Hz	60Hz				50Hz	60Hz	50Hz	60Hz	50Hz	60Hz	50Hz	60Hz			
Nomenclature details: p. 3																
3	483	583	01	- 507R	(-B)	- 3	1.88	1.56	0.191	0.159	235	235	24.0	24.0	V1	H1
5	290	350	01	- 507R	(-B)	- 5	3.13	2.59	0.319	0.264	392	392	40.0	40.0		
6	242	292	01	- 5067	(-B)	- 6	3.75	3.11	0.383	0.317	540	540	55.0	55.0	V2	H2
8	181	219	01	- 5067	(-B)	- 8	5.01	4.15	0.510	0.423	687	687	70.0	70.0		
11	132	159	01	- 5067	(-B)	- 11	6.88	5.70	0.702	0.581	687	687	70.0	70.0		
13	112	135	01	- 5067	(-B)	- 13	8.13	6.74	0.829	0.687	687	687	70.0	70.0		
15	96.7	117	01	- 5067	(-B)	- 15	9.39	7.78	0.957	0.793	883	883	90.0	90.0		
17	85.3	103	01	- 5067	(-B)	- 17	10.6	8.81	1.08	0.898	883	883	90.0	90.0		
21	69.0	83.3	01	- 5067	(-B)	- 21	13.1	10.9	1.34	1.11	1180	1180	120	120		
25	58.0	70.0	01	- 5067	(-B)	- 25	15.6	13.0	1.59	1.32	1180	1180	120	120		
29	50.0	60.3	01	- 5067	(-B)	- 29	18.1	15.0	1.85	1.53	1230	1230	125	125		
35	41.4	50.0	01	- 5067	(-B)	- 35	21.9	18.1	2.23	1.85	1230	1230	125	125		
43	33.7	40.7	01	- 5067	(-B)	- 43	26.9	22.3	2.74	2.27	1230	1230	125	125		
51	28.4	34.3	01	- 5067	(-B)	- 51	31.9	26.4	3.25	2.70	1230	1230	125	125		
59	24.6	29.7	01	- 5077	(-B)	- 59	36.9	30.6	3.76	3.12	1670	1670	170	170	V3	H3
71	20.4	24.6	01	- 5077	(-B)	- 71	44.4	36.8	4.53	3.75	1670	1670	170	170		
87	16.7	20.1	01	- 5087	(-B)	- 87	54.4	45.1	5.55	4.60	2700	2700	275	275	V4	H4
103	13.8	16.7	01	- 5097	(-B)	- 103	62.2	51.6	6.34	5.26	3430	3430	350	350	V5	H5
119	12.2	14.7	01	- 5097	(-B)	- 119	74.5	61.7	7.59	6.29	3430	3430	350	350		
145	10.0	12.1	01	- 5097DR	(-B)	- 145	86.0	71.2	8.76	7.26	3430	3430	350	350	V6	H6
175	8.29	10.0	01	- 5097DR	(-B)	- 175	104	86.0	10.6	8.76	3430	3430	350	350		
215	6.74	8.14	01	- 5097DR	(-B)	- 215	127	106	13.0	10.8	3430	3430	350	350		
255	5.69	6.86	01	- 5097DR	(-B)	- 255	151	125	15.4	12.8	3430	3430	350	350		
295	4.92	5.93	01	- 5097DR	(-B)	- 295	*174	145	*17.8	14.8	3430	3430	350	350		
355	4.08	4.93	01	- 5097DR	(-B)	- 355	*176	174	*18.0	17.8	3430	3430	350	350		
435	3.33	4.02	01	- 5107DR	(-B)	- 435	258	214	26.3	21.8	4660	4660	475	475	V7	H7
559	2.59	3.13	01	- 5107DA	(-B)	- 559	331	275	33.8	28.0	4660	4660	475	475	V8	H8
649	2.23	2.70	01	- 5107DA	(-B)	- 649	*363	319	*37.0	32.5	4660	4660	475	475		
731	1.98	2.39	01	- 5107DA	(-B)	- 731	*400	359	*40.8	36.6	4660	4660	475	475		
841	1.72	2.08	01	- 5127DA	(-B)	- 841	499	413	50.8	42.1	7260	7260	740	740	V9	H9
1003	1.45	1.74	01	- 5127DA	(-B)	- 1003	595	493	60.6	50.2	7260	7260	740	740		

- Note: 1. Output motor speed is the representative value at 1450r/min (50Hz) and 1750r/min (60Hz). Refer to page 31 for details.  
 2. Radial load at slow speed shaft is the value at the middle of the slow speed shaft.  
 3. Be careful for the models with asterisk, "\*" They are models with torque limitation.  
 4. Figure in the bracket ( ) shows the dimension for types with brake.  
 5. Models with "R" at the end of the nomenclature are the traction drive type. Make sure to read page 8 for cautions on traction drive types.

## Dimension Tables

Figure in the bracket ( ) shows the dimension for types with brake.

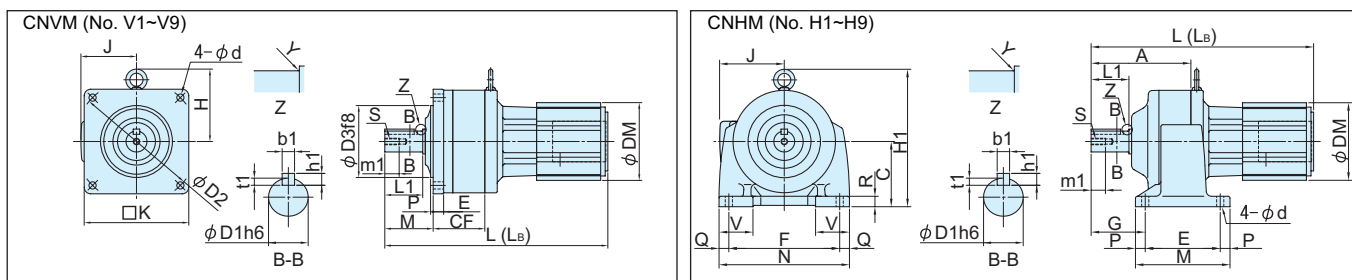

No.	Model	Main Body										Motor		Slow-speed Shaft Unit								Mass kg	
		CF	d	E	L	(L <sub>b</sub> )	M	P	D2	D3	H	K	J	DM	L1	m1	S	Y	D1	b1	h1		t1
V1	CNVM01-507R(-B)-Reduction Ratio	28	9	13	214	249	46	4	130	75	-	110	85	119	32	16	M6	0.4	18	6	6	3.5	6 (7)
V2	CNVM01-5067(-B)-Reduction Ratio	41	6.6	12	202	261	38	4	104	65	-	90	85	119	32	13	M5	0.5	16	5	5	3	4 (4.5)
V3	CNVM01-5077(-B)-Reduction Ratio	42	9	13	224	259	46	4	130	75	-	110	85	119	32	16	M6	1	18	6	6	3.5	5.5 (7)
V4	CNVM01-5087(-B)-Reduction Ratio	47	9	13	237	272	54	4	130	75	-	110	85	119	40	16	M6	1	22	6	6	3.5	6 (7.5)
V5	CNVM01-5097(-B)-Reduction Ratio	63	11	14	280	315	66	4	165	95	-	140	85	119	50	19	M8	2	28	8	7	4	8.5 (10)
V6	CNVM01-5097DR(-B)-Reduction Ratio	63	11	14	311	346	66	4	165	95	-	140	85	119	50	19	M8	2	28	8	7	4	9.5 (11)
V7	CNVM01-5107DR(-B)-Reduction Ratio	79	11	16	341	376	74	4	190	110	111	160	85	119	58	22	M10	2	32	10	8	5	13 (14)
V8	CNVM01-5107DA(-B)-Reduction Ratio	166	11	16	376	411	74	4	190	110	120	160	85	119	58	22	M10	2	32	10	8	5	14 (15)
V9	CNVM01-5127DA(-B)-Reduction Ratio	198	14	20	442	477	93	6	235	150	138	205	85	119	75	28	M12	3	42	12	8	5	32 (34)

No.	Model	Main Body												Motor		Slow-speed Shaft Unit								Mass kg			
		A	C	d	E	F	G	H1	L	(L <sub>b</sub> )	M	N	P	Q	R	V	J	DM	L1	m1	S	Y	D1		b1	h1	t1
H1	CNHM01-507R(-B)-Reduction Ratio	74	71	9	75	120	49	124	214	249	99	144	12	12	12	50	85	119	32	16	M6	0.4	18	6	6	3.5	6 (7)
H2	CNHM01-5067(-B)-Reduction Ratio	79	53	6.6	40	112	47	98	202	261	65	130	12.5	9	7	45	-	90	28	13	M5	0.5	16	5	5	3	4 (4.5)
H3	CNHM01-5077(-B)-Reduction Ratio	88	71	9	75	120	49	124	224	259	99	144	12	12	12	39	85	119	32	16	M6	1	18	6	6	3.5	6 (7.5)
H4	CNHM01-5087(-B)-Reduction Ratio	101	80	9	75	120	57	133	237	272	99	144	12	12	12	39	85	119	40	16	M6	1	22	6	6	3.5	6 (8)
H5	CNHM01-5097(-B)-Reduction Ratio	129	90	11	90	150	75	157	280	315	120	180	15	15	14	44	85	119	50	19	M8	2	28	8	7	4	9 (11)
H6	CNHM01-5097DR(-B)-Reduction Ratio	129	90	11	90	150	75	157	311	346	120	180	15	15	14	44	85	119	50	19	M8	2	28	8	7	4	10 (11)
H7	CNHM01-5107DR(-B)-Reduction Ratio	153	100	11	115	170	83	211	341	376	145	200	15	15	16	52	85	119	58	22	M10	2	32	10	8	5	14 (15)
H8	CNHM01-5107DA(-B)-Reduction Ratio	240	100	11	115	170	83	220	376	411	145	200	15	15	16	52	85	119	58	22	M10	2	32	10	8	5	15 (16)
H9	CNHM01-5127DA(-B)-Reduction Ratio	291	120	14	150	210	102	258	442	477	150	210	20	25	20	65	85	119	75	28	M12	3	42	12	8	5	34 (36)











# Gearmotors, Flange Mount Type (CNVM), Foot Mount Type (CNHM) 0.55kW Three-Phase Motor

## Selection Tables

Reduction Ratio	Output Speed		Input Capacity Symbol	Frame Size	Reduction Ratio	Output Torque Tout				Allowable Radial Load Pro				Dimension Table No.	
	r/min					N·m		kg·m		N		kgf		CNVM	CNHM
	50Hz	60Hz				50Hz	60Hz	50Hz	60Hz	50Hz	60Hz	50Hz	60Hz		
3	483	583	CNVM (Flange Mount) CNHM (Foot Mount)	08 - 508R (-B) -	3	10.3	8.55	1.05	0.872	603	603	62.0	62.0	V1	H1
5	290	350			5	17.2	14.3	1.75	1.45	1000	1000	102	102		
6	242	292			6	20.6	17.1	2.10	1.74	1000	1000	102	102	V2	H2
8	181	219			8	27.5	22.8	2.81	2.33	1000	1000	102	102		
11	132	159			11	37.9	31.4	3.86	3.20	1470	1470	150	150		
13	112	135			13	44.7	37.1	4.56	3.78	1470	1470	150	150		
15	96.7	117			15	51.6	42.8	5.26	4.36	1600	1600	163	163	V3	H3
17	85.3	103			17	58.5	48.5	5.96	4.94	1810	1810	185	185		
21	69.0	83.3			21	72.3	59.9	7.37	6.10	3430	3430	350	350		
25	58.0	70.0			25	86.0	71.3	8.77	7.27	3430	3430	350	350	V4	H4
29	50.0	60.3			29	99.8	82.7	10.2	8.43	3430	3430	350	350		
35	41.4	50.0			35	120	99.8	12.3	10.2	3430	3430	350	350		
43	33.7	40.7			43	148	123	15.1	12.5	3430	3430	350	350	V5	H5
51	28.4	34.3			51	176	145	17.9	14.8	3430	3430	350	350		
59	24.6	29.7			59	203	168	20.7	17.1	4660	4660	475	475		
71	20.4	24.6			71	244	202	24.9	20.6	4660	4660	475	475	V5	H5
87	16.7	20.1			87	299	248	30.5	25.3	4660	4660	475	475		
105	13.8	16.7			105	342	284	34.9	28.9	7260	7260	740	740		
125	11.6	14.0			125	408	338	41.5	34.4	7260	7260	740	740	V5	H5
145	10.0	12.1			145	473	392	48.2	39.9	7260	7260	740	740		
175	8.29	10.0	175	571	473	58.2	48.2	7260	7260	740	740				
215	6.74	8.14	215	701	581	71.5	59.2	7260	7260	740	740	V5	H5		
255	5.69	6.86	255	*740	689	*75.4	70.2	7260	7260	740	740				
295	4.92	5.93	295	*762	*762	*77.7	*77.7	7260	7260	740	740				
355	4.08	4.93	355	*604	*604	*61.5	*61.5	7260	7260	740	740	V5	H5		
435	3.33	4.02	435	*774	*774	*78.9	*78.9	7260	7260	740	740				

- Note: 1. Output motor speed is the representative value at 1450r/min (50Hz) and 1750r/min (60Hz). Refer to page 31 for details.  
 2. Radial load at slow speed shaft is the value at the middle of the slow speed shaft.  
 3. Be careful for the models with asterisk, "\*" They are models with torque limitation.  
 4. Figure in the bracket ( ) shows the dimension for types with brake.  
 5. Models with "R" at the end of the nomenclature are the traction drive type. Make sure to read page 8 for cautions on traction drive types.

## Dimension Tables

Figure in the bracket ( ) shows the dimension for types with brake.

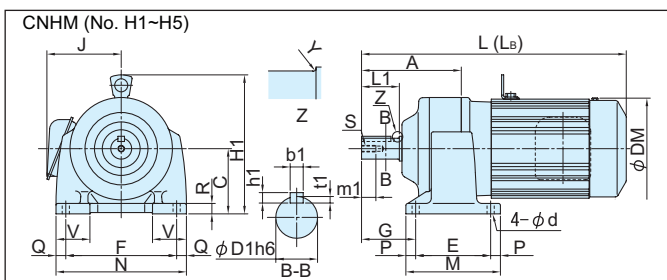
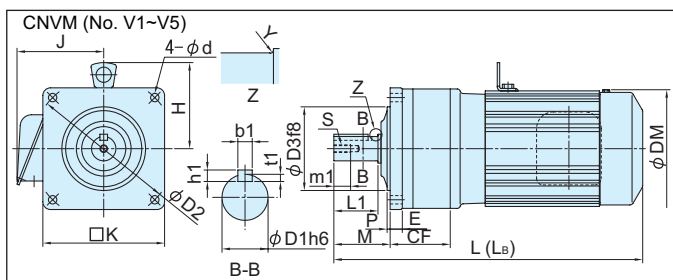

No.	Model	Main Body										Motor		Slow-speed Shaft Unit							Mass kg		
		CF	d	E	L	(L <sub>B</sub> )	M	P	D2	D3	H	K	J	DM	L1	m1	S	Y	D1	b1		h1	t1
V1	CNVM08-508R(-B)-Reduction Ratio	57	9	13	353	396	54	4	130	75	-	113	114	155	40	16	M6	0.4	22	6	6	3.5	12 (14)
V2	CNVM08-5087(-B)-Reduction Ratio	47	9	13	350	393	54	4	130	75	-	110	114	155	40	16	M6	1	22	6	6	3.5	10 (13)
V3	CNVM08-5097(-B)-Reduction Ratio	63	11	14	378	421	66	4	165	95	-	140	114	155	50	19	M8	2	28	8	7	4	12 (15)
V4	CNVM08-5107(-B)-Reduction Ratio	79	11	16	406	449	74	4	190	110	113	160	114	155	58	22	M10	2	32	10	8	5	16 (18)
V5	CNVM08-5127DR(-B)-Reduction Ratio	172	14	20	507	550	93	6	235	150	138	205	114	155	75	28	M12	3	42	12	8	5	36 (39)

No.	Model	Main Body										Motor		Slow-speed Shaft Unit							Mass kg						
		A	C	d	E	F	G	H1	L	(L <sub>B</sub> )	M	N	P	Q	R	V	J	DM	L1	m1		S	Y	D1	b1	h1	t1
H1	CNHM08-508R(-B)-Reduction Ratio	111	80	9	75	120	57	193	353	396	99	144	12	12	13	50	114	155	40	16	M6	0.4	22	6	6	3.5	12 (14)
H2	CNHM08-5087(-B)-Reduction Ratio	101	80	9	75	120	57	193	350	393	99	144	12	12	13	39	114	155	40	16	M6	1	22	6	6	3.5	10 (13)
H3	CNHM08-5097(-B)-Reduction Ratio	129	90	11	90	150	75	203	378	421	120	180	15	15	14	44	114	155	50	19	M8	2	28	8	7	4	13 (16)
H4	CNHM08-5107(-B)-Reduction Ratio	153	100	11	115	170	83	213	406	449	145	200	15	15	16	52	114	155	58	22	M10	2	32	10	8	5	17 (19)
H5	CNHM08-5127DR(-B)-Reduction Ratio	265	120	14	150	210	102	258	507	550	190	260	20	25	20	65	114	155	75	28	M12	3	42	12	8	5	37 (39)

# Gearmotors, Flange Mount Type (CNVM), Foot Mount Type (CNHM) 0.75kW Three-Phase Motor

## Selection Tables

Reduction Ratio	Output Speed		Input Capacity Symbol	Frame Size	Reduction Ratio	Output Torque Tout				Allowable Radial Load Pro				Dimension Table No.	
	r/min					N·m		kg·m		N		kgf		CNVM	CNHM
	50Hz	60Hz				50Hz	60Hz	50Hz	60Hz	50Hz	60Hz	50Hz	60Hz		
Nomenclature details: p. 3															
3	483	583	1	- 508R (-B)	3	14.1	11.7	1.44	1.19	603	603	62.0	62.0	V1	H1
5	290	350	1	- 508R (-B)	5	23.5	19.4	2.39	1.98	1000	1000	102	102	V2	H2
6	242	292	1	- 5087 (-B)	6	28.2	23.3	2.87	2.38	1000	1000	102	102	V3	H3
8	181	219	1	- 5087 (-B)	8	37.5	31.1	3.83	3.17	1000	1000	102	102		
11	132	159	1	- 5097 (-B)	11	51.6	42.8	5.26	4.36	2450	2450	250	250		
13	112	135	1	- 5097 (-B)	13	61.0	50.5	6.22	5.15	2750	2750	280	280		
15	96.7	117	1	- 5097 (-B)	15	70.4	58.3	7.18	5.95	2850	2850	290	290		
17	85.3	103	1	- 5097 (-B)	17	79.8	66.1	8.13	6.74	3240	3240	330	330		
21	69.0	83.3	1	- 5097 (-B)	21	98.5	81.7	10.0	8.32	3430	3430	350	350		
25	58.0	70.0	1	- 5097 (-B)	25	117	97.2	12.0	9.91	3430	3430	350	350		
29	50.0	60.3	1	- 5097 (-B)	29	136	113	13.9	11.5	3430	3430	350	350		
35	41.4	50.0	1	- 5097 (-B)	35	164	136	16.7	13.9	3430	3430	350	350		
43	33.7	40.7	1	- 5097 (-B)	43	202	167	20.6	17.0	3430	3430	350	350		
51	28.4	34.3	1	- 5107 (-B)	51	239	198	24.4	20.2	4660	4660	475	475	V4	H4
59	24.6	29.7	1	- 5107 (-B)	59	277	229	28.2	23.4	4660	4660	475	475	V5	H5
71	20.4	24.6	1	- 5117 (-B)	71	333	276	34.0	28.1	5690	5690	580	580		
87	16.7	20.1	1	- 5117 (-B)	87	408	338	41.6	34.5	5690	5690	580	580		
105	13.8	16.7	1	- 5127DR (-B)	105	467	387	47.6	39.4	7260	7260	740	740	V6	H6
125	11.6	14.0	1	- 5127DR (-B)	125	556	460	56.6	46.9	7260	7260	740	740		
145	10.0	12.1	1	- 5127DR (-B)	145	645	534	65.7	54.4	7260	7260	740	740		
175	8.29	10.0	1	- 5127DR (-B)	175	*664	645	*67.7	65.7	7260	7260	740	740		
215	6.74	8.14	1	- 5127DR (-B)	215	*711	*711	*72.5	*72.5	7260	7260	740	740		
255	5.69	6.86	1	- 5127DR (-B)	255	*740	*740	*75.4	*75.4	7260	7260	740	740		

- Note: 1. Output motor speed is the representative value at 1450r/min (50Hz) and 1750r/min (60Hz). Refer to page 31 for details.  
 2. Radial load at slow speed shaft is the value at the middle of the slow speed shaft.  
 3. Be careful for the models with asterisk, "\*" They are models with torque limitation.  
 4. Figure in the bracket ( ) shows the dimension for types with brake.  
 5. Models with "R" at the end of the nomenclature are the traction drive type. Make sure to read page 8 for cautions on traction drive types.

## Dimension Tables

Figure in the bracket ( ) shows the dimension for types with brake.

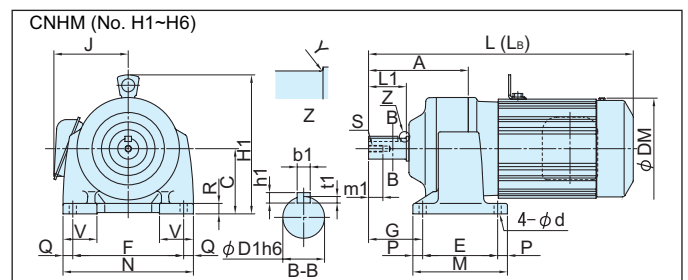
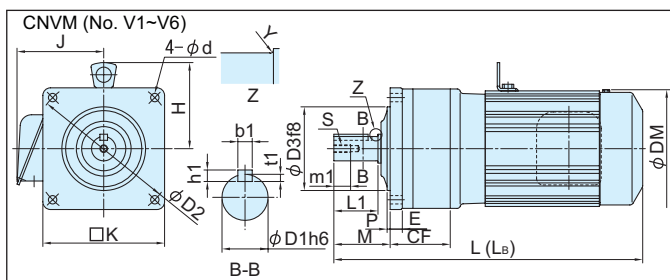

No.	Model	Main Body										Motor		Slow-speed Shaft Unit							Mass		
		CF	d	E	L (L <sub>b</sub> )	M	P	D2	D3	H	K	J	DM	L1	m1	S	Y	D1	b1	h1	t1	kg	
V1	CNVM1-508R(-B)-Reduction Ratio	57	9	13	353	396	54	4	130	75	-	113	114	155	40	16	M6	0.4	22	6	6	3.5	13 (15)
V2	CNVM1-5087(-B)-Reduction Ratio	47	9	13	350	393	54	4	130	75	-	110	114	155	40	16	M6	1	22	6	6	3.5	11 (14)
V3	CNVM1-5097(-B)-Reduction Ratio	63	11	14	378	421	66	4	165	90	-	140	114	155	50	19	M8	2	28	8	7	4	13 (16)
V4	CNVM1-5107(-B)-Reduction Ratio	79	11	16	406	449	74	4	190	110	113	160	114	155	58	22	M10	2	32	10	8	5	17 (19)
V5	CNVM1-5117(-B)-Reduction Ratio	88	14	18	445	488	86	6	215	130	113	185	114	155	68	22	M10	3	38	10	8	5	29 (31)
V6	CNVM1-5127DR(-B)-Reduction Ratio	172	14	20	507	550	93	6	235	150	138	205	114	155	75	28	M12	3	42	12	8	5	37 (40)

No.	Model	Main Body										Motor		Slow-speed Shaft Unit							Mass						
		A	C	d	E	F	G	H1	L (L <sub>b</sub> )	M	N	P	Q	R	V	J	DM	L1	m1	S	Y	D1	b1	h1	t1	kg	
H1	CNHM1-508R(-B)-Reduction Ratio	111	80	9	75	120	57	193	353	396	99	144	12	12	13	50	114	155	40	16	M6	0.4	22	6	6	3.5	13 (15)
H2	CNHM1-5087(-B)-Reduction Ratio	101	80	9	75	120	57	193	350	393	99	144	12	12	13	39	114	155	40	16	M6	1	22	6	6	3.5	11 (14)
H3	CNHM1-5097(-B)-Reduction Ratio	129	90	11	90	150	75	203	378	421	120	180	15	15	14	44	114	155	50	19	M8	2	28	8	7	4	14 (17)
H4	CNHM1-5107(-B)-Reduction Ratio	153	100	11	115	170	83	213	406	449	145	200	15	15	16	52	114	155	58	22	M10	2	32	10	8	5	18 (20)
H5	CNHM1-5117(-B)-Reduction Ratio	174	120	14	135	190	95	233	445	488	175	230	20	20	18	60	114	155	68	22	M10	3	38	10	8	5	31 (34)
H6	CNHM1-5127DR(-B)-Reduction Ratio	265	120	14	150	210	102	258	507	550	190	260	20	25	20	65	114	155	75	28	M12	3	42	12	8	5	37 (40)

# Gearmotors, Flange Mount Type (CNVM), Foot Mount Type (CNHM)

## 1.1kW Three-Phase Motor

### Selection Tables

Reduction Ratio	Output Speed		Input Capacity Symbol	Frame Size	Reduction Ratio	Output Torque Tout				Allowable Radial Load Pro				Dimension Table No.		
	r/min					N·m		kg·m		N		kgf		CNVM	CNHM	
	50Hz	60Hz				50Hz	60Hz	50Hz	60Hz	50Hz	60Hz					
Nomenclature details: p. 3																
3	483	583	1H	- 509R	(-B)	- 3	20.6	17.1	2.10	1.74	948	948	97.0	97.0	V1	H1
5	290	350	1H	- 509R	(-B)	- 5	34.4	28.5	3.51	2.91	1580	1580	161	161	V2	H2
6	242	292	1H	- 5097	(-B)	- 6	41.3	34.2	4.21	3.49	1960	1960	200	200		
8	181	219	1H	- 5097	(-B)	- 8	55.1	45.6	5.61	4.65	2450	2450	250	250		
11	132	159	1H	- 5097	(-B)	- 11	75.7	62.7	7.72	6.39	2450	2450	250	250		
13	112	135	1H	- 5097	(-B)	- 13	89.5	74.1	9.12	7.56	2750	2750	280	280		
15	96.7	117	1H	- 5097	(-B)	- 15	103	85.5	10.5	8.72	2850	2850	290	290	V3	H3
17	85.3	103	1H	- 5097	(-B)	- 17	117	96.9	11.9	9.88	3240	3240	330	330		
21	69.0	83.3	1H	- 5097	(-B)	- 21	145	120	14.7	12.2	3430	3430	350	350		
25	58.0	70.0	1H	- 5097	(-B)	- 25	172	143	17.5	14.5	3430	3430	350	350		
29	50.0	60.3	1H	- 5107	(-B)	- 29	200	165	20.3	16.9	4660	4660	475	475		
35	41.4	50.0	1H	- 5107	(-B)	- 35	241	200	24.6	20.3	4660	4660	475	475	V4	H4
43	33.7	40.7	1H	- 5107	(-B)	- 43	296	245	30.2	25.0	4660	4660	475	475		
51	28.4	34.3	1H	- 5107	(-B)	- 51	351	291	35.8	29.6	4500	4660	459	475		
59	24.6	29.7	1H	- 5117	(-B)	- 59	406	336	41.4	34.3	5690	5690	580	580		
71	20.4	24.6	1H	- 5117	(-B)	- 71	489	405	49.8	41.3	5690	5690	580	580		
87	16.7	20.1	1H	- 5127	(-B)	- 87	599	496	61.0	50.6	7260	7260	740	740	V5	H5

- Note: 1. Output motor speed is the representative value at 1450r/min (50Hz) and 1750r/min (60Hz). Refer to page 31 for details.  
 2. Radial load at slow speed shaft is the value at the middle of the slow speed shaft.  
 3. Figure in the bracket ( ) shows the dimension for types with brake.  
 4. Models with "R" at the end of the nomenclature are the traction drive type. Make sure to read page 8 for cautions on traction drive types.

### Dimension Tables

Figure in the bracket ( ) shows the dimension for types with brake.

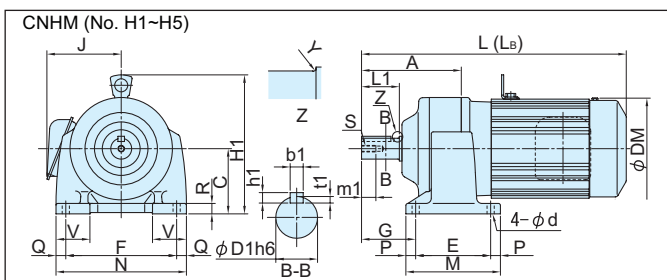
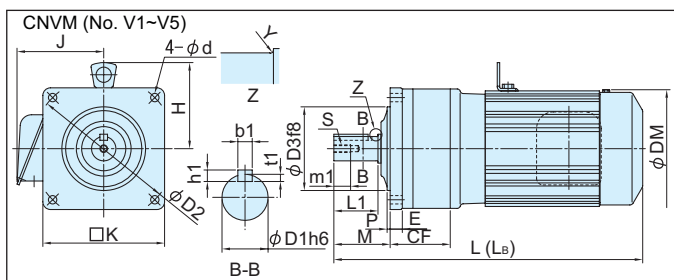

No.	Model	Main Body										Motor		Slow-speed Shaft Unit								Mass	
		CF	d	E	L	(L <sub>B</sub> )	M	P	D2	D3	H	K	J	DM	L1	m1	S	Y	D1	b1	h1	t1	kg
V1	CNVM1H-509R(-B)-Reduction Ratio	79	11	14	415	477	66	4	165	95	120	142	119	167	50	19	M8	0.4	28	8	7	4	20 (25)
V2	CNVM1H-5097(-B)-Reduction Ratio	63	11	14	410	472	66	4	165	95	120	140	119	167	50	19	M8	2	28	8	7	4	16 (21)
V3	CNVM1H-5107(-B)-Reduction Ratio	79	11	16	437	499	74	4	190	110	120	160	119	167	58	22	M10	2	32	10	8	5	19 (24)
V4	CNVM1H-5117(-B)-Reduction Ratio	88	14	18	473	535	86	6	215	130	120	185	119	167	68	22	M10	3	38	10	8	5	31 (36)
V5	CNVM1H-5127(-B)-Reduction Ratio	93	14	20	485	547	93	6	235	150	120	205	119	167	75	28	M12	3	42	12	8	5	38 (43)

No.	Model	Main Body										Motor		Slow-speed Shaft Unit								Mass					
		A	C	d	E	F	G	H1	L	(L <sub>B</sub> )	M	N	P	Q	R	V	J	DM	L1	m1	S	Y	D1	b1	h1	t1	kg
H1	CNHM1H-509R(-B)-Reduction Ratio	145	90	11	90	150	75	210	415	477	120	180	15	15	14	70	119	167	50	19	M8	0.4	28	8	7	4	20 (25)
H2	CNHM1H-5097(-B)-Reduction Ratio	129	90	11	90	150	75	210	410	472	120	180	15	15	14	44	119	167	50	19	M8	2	28	8	7	4	16 (21)
H3	CNHM1H-5107(-B)-Reduction Ratio	153	100	11	115	170	83	220	437	499	145	200	15	15	16	52	119	167	58	22	M10	2	32	10	8	5	20 (25)
H4	CNHM1H-5117(-B)-Reduction Ratio	174	120	14	135	190	95	240	473	535	175	230	20	20	18	60	119	167	68	22	M10	3	38	10	8	5	34 (39)
H5	CNHM1H-5127(-B)-Reduction Ratio	186	120	14	150	210	102	240	485	547	190	260	20	25	20	65	119	167	75	28	M12	3	42	12	8	5	41 (46)

# Gearmotors, Flange Mount Type (CNVM), Foot Mount Type (CNHM) 1.5kW Three-Phase Motor

## Selection Tables

Reduction Ratio	Output Speed		Input Capacity Symbol	Frame Size	Reduction Ratio	Output Torque Tout				Allowable Radial Load Pro				Dimension Table No.	
	r/min					N·m		kg·m		N		kgf		CNVM	CNHM
	50Hz	60Hz				50Hz	60Hz	50Hz	60Hz	50Hz	60Hz	50Hz	60Hz		
Nomenclature details: p. 3															
3	483	583	2	- 509R (-B)	- 3	28.2	23.3	2.87	2.38	948	948	97.0	97.0	V1	H1
5	290	350	2	- 509R (-B)	- 5	46.9	38.9	4.78	3.96	1580	1580	161	161		
6	242	292	2	- 5097 (-B)	- 6	56.3	46.7	5.74	4.76	1960	1960	200	200		
8	181	219	2	- 5097 (-B)	- 8	75.1	62.2	7.65	6.34	2450	2450	250	250		
11	132	159	2	- 5097 (-B)	- 11	103	85.5	10.5	8.72	2450	2450	250	250		
13	112	135	2	- 5097 (-B)	- 13	122	101	12.4	10.3	2750	2750	280	280	V2	H2
15	96.7	117	2	- 5097 (-B)	- 15	141	117	14.4	11.9	2850	2850	290	290		
17	85.3	103	2	- 5097 (-B)	- 17	160	132	16.3	13.5	3240	3240	330	330		
21	69.0	83.3	2	- 5097 (-B)	- 21	197	163	20.1	16.6	3430	3430	350	350		
25	58.0	70.0	2	- 5107 (-B)	- 25	235	194	23.9	19.8	4660	4660	475	475		
29	50.0	60.3	2	- 5107 (-B)	- 29	272	226	27.7	23.0	4660	4660	475	475	V3	H3
35	41.4	50.0	2	- 5107 (-B)	- 35	328	272	33.5	27.7	4590	4660	467	475		
43	33.7	40.7	2	- 5117 (-B)	- 43	404	334	41.1	34.1	5690	5690	580	580	V4	H4
51	28.4	34.3	2	- 5117 (-B)	- 51	479	397	48.8	40.4	5690	5690	580	580		
59	24.6	29.7	2	- 5127 (-B)	- 59	554	459	56.4	46.8	7260	7260	740	740	V5	H5

- Note: 1. Output motor speed is the representative value at 1450r/min (50Hz) and 1750r/min (60Hz). Refer to page 31 for details.  
 2. Radial load at slow speed shaft is the value at the middle of the slow speed shaft.  
 3. Figure in the bracket ( ) shows the dimension for types with brake.  
 4. Models with "R" at the end of the nomenclature are the traction drive type. Make sure to read page 8 for cautions on traction drive types.

## Dimension Tables

Figure in the bracket ( ) shows the dimension for types with brake.

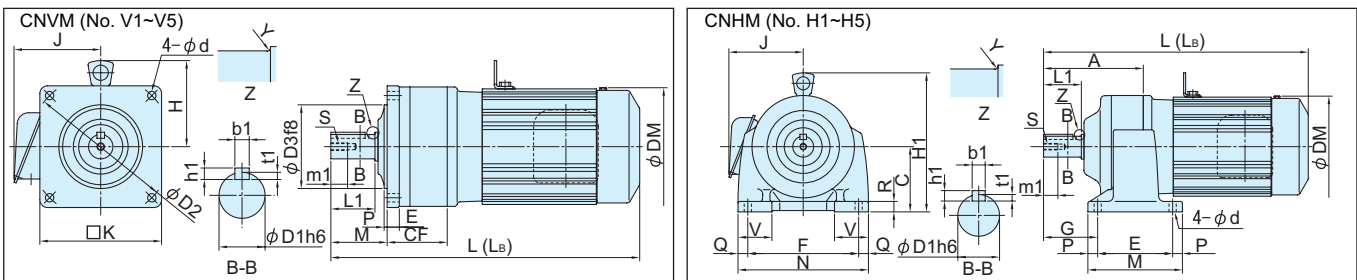

No.	Model	Main Body										Motor		Slow-speed Shaft Unit						Mass			
		CF	d	E	L	(L <sub>b</sub> )	M	P	D2	D3	H	K	J	DM	L1	m1	S	Y	D1	b1	h1	t1	kg
V1	CNVM2-509R(-B)-Reduction Ratio	79	11	14	415	477	66	4	165	95	120	142	119	167	50	19	M8	0.4	28	8	7	4	21 (26)
V2	CNVM2-5097(-B)-Reduction Ratio	63	11	14	410	472	66	4	165	95	120	140	119	167	50	19	M8	2	28	8	7	4	17 (22)
V3	CNVM2-5107(-B)-Reduction Ratio	79	11	16	437	499	74	4	190	110	120	160	119	167	58	22	M10	2	32	10	8	5	20 (23)
V4	CNVM2-5117(-B)-Reduction Ratio	88	14	18	473	535	86	6	215	130	120	185	119	167	68	22	M10	3	38	10	8	5	33 (37)
V5	CNVM2-5127(-B)-Reduction Ratio	93	14	20	485	547	93	6	235	150	120	205	119	167	75	28	M12	3	42	12	8	5	40 (45)

No.	Model	Main Body										Motor		Slow-speed Shaft Unit						Mass							
		A	C	d	E	F	G	H1	L	(L <sub>b</sub> )	M	N	P	Q	R	V	J	DM	L1	m1	S	Y	D1	b1	h1	t1	kg
H1	CNHM2-509R(-B)-Reduction Ratio	145	90	11	90	150	75	210	415	477	120	180	15	15	14	70	119	167	50	19	M8	0.4	28	8	7	4	21 (26)
H2	CNHM2-5097(-B)-Reduction Ratio	129	90	11	90	150	75	210	410	472	120	180	15	15	14	44	119	167	50	19	M8	2	28	8	7	4	18 (23)
H3	CNHM2-5107(-B)-Reduction Ratio	153	100	11	115	170	83	220	437	499	145	200	15	15	16	52	119	167	58	22	M10	2	32	10	8	5	21 (26)
H4	CNHM2-5117(-B)-Reduction Ratio	174	120	14	135	190	95	240	473	535	175	230	20	20	18	60	119	167	68	22	M10	3	38	10	8	5	35 (40)
H5	CNHM2-5127(-B)-Reduction Ratio	186	120	14	150	210	102	240	485	547	190	260	20	25	20	65	119	167	75	28	M12	3	42	12	8	5	42 (47)

# Gearmotors, Flange Mount Type (CNVM), Foot Mount Type (CNHM) 2.2kW Three-Phase Motor

## Selection Tables

Reduction Ratio	Output Speed		Input Capacity Symbol	Frame Size	Reduction Ratio	Output Torque Tout				Allowable Radial Load Pro				Dimension Table No.						
	r/min					N·m		kg·m		N		kgf		CNVM	CNHM					
	50Hz	60Hz				50Hz	60Hz	50Hz	60Hz	50Hz	60Hz	50Hz	60Hz							
3	483	583	CNVM (Flange Mount) CNHM (Foot Mount)	Nomenclature details: p. 3	3	-	510R	(-B)	-	3	41.3	34.2	4.21	3.49	1220	1220	124	124	V1	H1
5	290	350			3	-	510R	(-B)	-	5	68.8	57.0	7.02	5.81	2030	2030	207	207		
8	181	219			3	-	5107	(-B)	-	8	110	91.2	11.2	9.30	2970	2970	303	303	V2	H2
11	132	159			3	-	5107	(-B)	-	11	151	125	15.4	12.8	2970	2970	303	303		
13	112	135			3	-	5107	(-B)	-	13	179	148	18.2	15.1	3510	3510	358	358		
15	96.7	117			3	-	5107	(-B)	-	15	206	171	21.0	17.4	4050	4050	413	413		
17	85.3	103			3	-	5107	(-B)	-	17	234	194	23.9	19.8	4590	4590	468	468		
21	69.0	83.3			3	-	5107	(-B)	-	21	289	240	29.5	24.4	4660	4660	475	475		
25	58.0	70.0			3	-	5117	(-B)	-	25	344	285	35.1	29.1	5690	5690	580	580	V3	H3
29	50.0	60.3			3	-	5117	(-B)	-	29	399	331	40.7	33.7	5690	5690	580	580		
35	41.4	50.0			3	-	5117	(-B)	-	35	482	399	49.1	40.7	5690	5690	580	580		
43	33.7	40.7			3	-	5117	(-B)	-	43	592	490	60.3	50.0	5690	5690	580	580		
51	28.4	34.3			3	-	5127	(-B)	-	51	702	582	71.6	59.3	7260	7260	740	740	V4	H4

- Note: 1. Output motor speed is the representative value at 1450r/min (50Hz) and 1750r/min (60Hz). Refer to page 31 for details.  
 2. Radial load at slow speed shaft is the value at the middle of the slow speed shaft.  
 3. Figure in the bracket ( ) shows the dimension for types with brake.  
 4. Models with "R" at the end of the nomenclature are the traction drive type. Make sure to read page 8 for cautions on traction drive types.

## Dimension Tables

Figure in the bracket ( ) shows the dimension for types with brake.

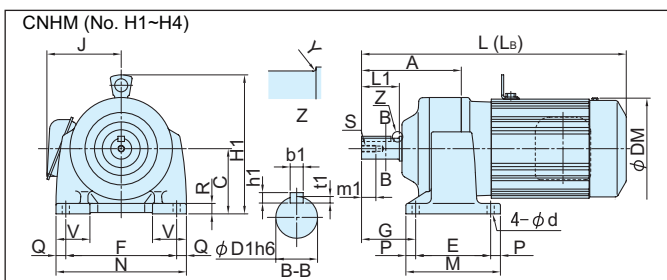
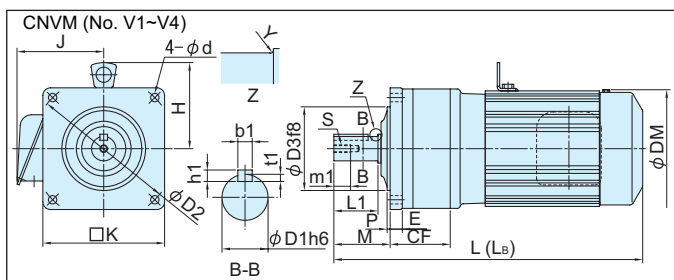

No.	Model	Main Body										Motor		Slow-speed Shaft Unit							Mass		
		CF	d	E	L	(L <sub>b</sub> )	M	P	D2	D3	H	K	J	DM	L1	m1	S	Y	D1	b1	h1	t1	kg
V1	CNVM3-510R(-B)-Reduction Ratio	92	11	16	456	519	74	4	190	110	126	160	126	180	58	22	M10	0.4	32	10	8	5	27 (33)
V2	CNVM3-5107(-B)-Reduction Ratio	79	11	16	456	519	74	4	190	110	126	160	126	180	58	22	M10	2	32	10	8	5	25 (31)
V3	CNVM3-5117(-B)-Reduction Ratio	88	14	18	490	553	86	6	215	130	126	185	126	180	68	22	M10	3	38	10	8	5	36 (42)
V4	CNVM3-5127(-B)-Reduction Ratio	93	14	20	502	565	93	6	235	150	126	205	126	180	75	28	M12	3	42	12	8	5	44 (50)

No.	Model	Main Body										Motor		Slow-speed Shaft Unit							Mass						
		A	C	d	E	F	G	H1	L	(L <sub>b</sub> )	M	N	P	Q	R	V	J	DM	L1	m1	S	Y	D1	b1	h1	t1	kg
H1	CNHM3-510R(-B)-Reduction Ratio	166	100	11	115	170	83	226	456	519	145	200	15	15	16	75	126	180	58	22	M10	0.4	32	10	8	5	27 (33)
H2	CNHM3-5107(-B)-Reduction Ratio	153	100	11	115	170	83	226	456	519	145	200	15	15	16	52	126	180	58	22	M10	2	32	10	8	5	26 (32)
H3	CNHM3-5117(-B)-Reduction Ratio	174	120	14	135	190	95	246	490	553	175	230	20	20	18	60	126	180	68	22	M10	3	38	10	8	5	39 (45)
H4	CNHM3-5127(-B)-Reduction Ratio	186	120	14	150	210	102	246	502	565	190	260	20	25	20	65	126	180	75	28	M12	3	42	12	8	5	46 (52)

# Gearmotors, Flange Mount Type (CNVM), Foot Mount Type (CNHM) 90W Single-Phase Motor

## Selection Tables

Reduction Ratio	Output Speed		Input Capacity - Frame Size - Suffix - Reduction Ratio	Output Torque Tout				Allowable Radial Load Pro				Dimension Table No.	
	r/min			N·m		kgf·m		N		kgf		CNVM	CNHM
	50Hz	60Hz		50Hz	60Hz	50Hz	60Hz	50Hz	60Hz	50Hz	60Hz		
Nomenclature details: p. 3													
6	242	292	009 - 5067 - CA (-B) - 6	3.38	2.80	0.344	0.285	540	540	55.0	55.0	V1	H1
8	181	219	009 - 5067 - CA (-B) - 8	4.50	3.73	0.459	0.380	687	687	70.0	70.0		
11	132	159	009 - 5067 - CA (-B) - 11	6.19	5.13	0.631	0.523	687	687	70.0	70.0		
13	112	135	009 - 5067 - CA (-B) - 13	7.32	6.07	0.746	0.618	687	687	70.0	70.0		
15	96.7	117	009 - 5067 - CA (-B) - 15	8.45	7.00	0.861	0.713	883	883	90.0	90.0		
17	85.3	103	009 - 5067 - CA (-B) - 17	9.57	7.93	0.976	0.809	883	883	90.0	90.0		
21	69.0	83.3	009 - 5067 - CA (-B) - 21	11.8	9.80	1.21	0.999	1180	1180	120	120		
25	58.0	70.0	009 - 5067 - CA (-B) - 25	14.1	11.7	1.44	1.19	1180	1180	120	120		
29	50.0	60.3	009 - 5067 - CA (-B) - 29	16.3	13.5	1.66	1.38	1230	1230	125	125		
35	41.4	50.0	009 - 5067 - CA (-B) - 35	19.7	16.3	2.01	1.66	1230	1230	125	125		
43	33.7	40.7	009 - 5067 - CA (-B) - 43	24.2	20.1	2.47	2.05	1230	1230	125	125		
51	28.4	34.3	009 - 5067 - CA (-B) - 51	28.7	23.8	2.93	2.43	1230	1230	125	125		

Note: 1. Output motor speed is the representative value at 1450r/min (50Hz) and 1750r/min (60Hz). Refer to page 32 for details.  
 2. Radial load at slow speed shaft is the value at the middle of the slow speed shaft.  
 3. Figure in the bracket ( ) shows the dimension for types with brake.

## Dimension Tables

Figure in the bracket ( ) shows the dimension for types with brake.

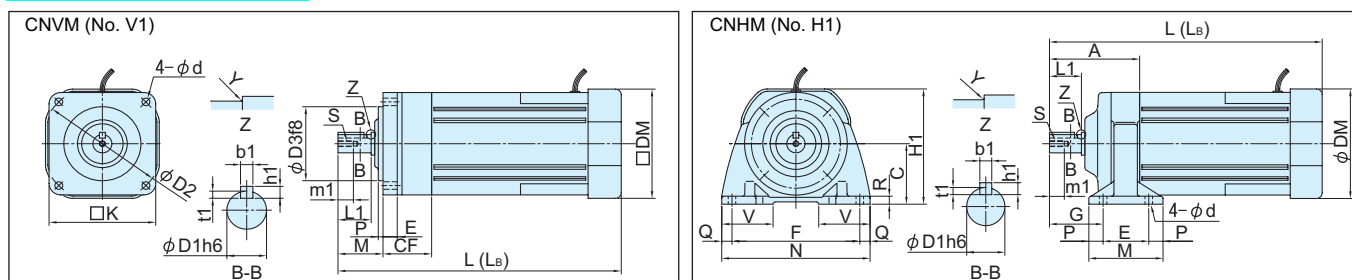

No.	Model	Main Body									Motor		Slow-speed Shaft Unit							Mass		
		CF	d	E	L	(L <sub>b</sub> )	M	P	D2	D3	K	J	DM	L1	m1	S	Y	D1	b1	h1	t1	kg
V1	CNVM009-5067-CA(-B)-Reduction Ratio	41	6.6	12	202	261	38	4	104	65	90	-	90	28	13	M5	0.5	16	5	5	3	4.5 (5)

No.	Model	Main Body													Motor		Slow-speed Shaft Unit							Mass			
		A	C	d	E	F	G	H1	L	(L <sub>b</sub> )	M	N	P	Q	R	V	J	DM	L1	m1	S	Y	D1	b1	h1	t1	kg
H1	CNHM009-5067-CA(-B)-Reduction Ratio	79	53	6.6	40	112	47	101	239	279	65	130	12.5	9	7	45	-	96	28	13	M5	0.5	16	5	5	3	4.5 (5)



# Gearmotors, Flange Mount Type (CNVM), Foot Mount Type (CNHM) 0.1kW Single-Phase Motor

## Selection Tables

Reduction Ratio	Output Speed		Input Capacity - Frame Size - Suffix - Reduction Ratio	Output Torque Tout				Allowable Radial Load Pro				Dimension Table No.	
	r/min			N·m		kgf·m		N		kgf		CNVM	CNHM
	50Hz	60Hz		50Hz	60Hz	50Hz	60Hz	50Hz	60Hz	50Hz	60Hz		
3	483	583	01 - 507R - CB (-B) - 3	1.88	1.56	0.191	0.159	235	235	24.0	24.0	V1	H1
5	290	350	01 - 507R - CB (-B) - 5	3.13	2.59	0.319	0.264	392	392	40.0	40.0		
6	242	292	01 - 506H - CB (-B) - 6	3.75	3.11	0.383	0.317	540	540	55.0	55.0	V2	H2
8	181	219	01 - 506H - CB (-B) - 8	5.01	4.15	0.510	0.423	687	687	70.0	70.0		
11	132	159	01 - 506H - CB (-B) - 11	6.88	5.70	0.702	0.581	687	687	70.0	70.0		
13	112	135	01 - 506H - CB (-B) - 13	8.13	6.74	0.829	0.687	687	687	70.0	70.0		
15	96.7	117	01 - 506H - CB (-B) - 15	9.39	7.78	0.957	0.793	883	883	90.0	90.0		
17	85.3	103	01 - 506H - CB (-B) - 17	10.6	8.81	1.08	0.898	883	883	90.0	90.0		
21	69.0	83.3	01 - 506H - CB (-B) - 21	13.1	10.9	1.34	1.11	1180	1180	120	120		
25	58.0	70.0	01 - 506H - CB (-B) - 25	15.6	13.0	1.59	1.32	1180	1180	120	120		
29	50.0	60.3	01 - 506H - CB (-B) - 29	18.1	15.0	1.85	1.53	1230	1230	125	125		
35	41.4	50.0	01 - 506H - CB (-B) - 35	21.9	18.1	2.23	1.85	1230	1230	125	125		
43	33.7	40.7	01 - 506H - CB (-B) - 43	26.9	22.3	2.74	2.27	1230	1230	125	125		
51	28.4	34.3	01 - 506H - CB (-B) - 51	31.9	26.4	3.25	2.70	1230	1230	125	125		
59	24.6	29.7	01 - 5077 - CB (-B) - 59	36.9	30.6	3.76	3.12	1670	1670	170	170	V3	H3
71	20.4	24.6	01 - 5077 - CB (-B) - 71	44.4	36.8	4.53	3.75	1670	1670	170	170		
87	16.7	20.1	01 - 5087 - CB (-B) - 87	54.4	45.1	5.55	4.60	2700	2700	275	275	V4	H4
103	13.8	16.7	01 - 5097 - CB (-B) - 103	62.2	51.6	6.34	5.26	3430	3430	350	350	V5	H5
119	12.2	14.7	01 - 5097 - CB (-B) - 119	74.5	61.7	7.59	6.29	3430	3430	350	350		
145	10.0	12.1	01 - 5097DR - CB (-B) - 145	86.0	71.2	8.76	7.26	3430	3430	350	350	V6	H6
175	8.29	10.0	01 - 5097DR - CB (-B) - 175	104	86.0	10.6	8.76	3390	3430	346	350		
215	6.74	8.14	01 - 5097DR - CB (-B) - 215	127	106	13.0	10.8	3430	3430	350	350		
255	5.69	6.86	01 - 5097DR - CB (-B) - 255	151	125	15.4	12.8	3430	3430	350	350		
295	4.92	5.93	01 - 5097DR - CB (-B) - 295	*174	145	*17.8	14.8	3430	3430	350	350		
355	4.08	4.93	01 - 5097DR - CB (-B) - 355	*176	174	*18.0	17.8	3430	3430	350	350		
435	3.33	4.02	01 - 5107DR - CB (-B) - 435	258	214	26.3	21.8	4660	4660	475	475	V7	H7
559	2.59	3.13	01 - 5107DA - CB (-B) - 559	331	275	33.8	28.0	4660	4660	475	475	V8	H8
649	2.23	2.70	01 - 5107DA - CB (-B) - 649	*363	319	*37.0	32.5	4660	4660	475	475		
731	1.98	2.39	01 - 5107DA - CB (-B) - 731	*400	359	*40.8	36.6	4660	4660	475	475		
841	1.72	2.08	01 - 5127DA - CB (-B) - 841	499	413	50.8	42.1	7260	7260	740	740	V9	H9
1003	1.45	1.74	01 - 5127DA - CB (-B) - 1003	595	493	60.6	50.2	7260	7260	740	740		

- Note: 1. Output motor speed is the representative value at 1450r/min (50Hz) and 1750r/min (60Hz). Refer to page 32 for details.  
 2. Radial load at slow speed shaft is the value at the middle of the slow speed shaft.  
 3. Be careful for the models with asterisk, "\*" They are models with torque limitation.  
 4. Figure in the bracket ( ) shows the dimension for types with brake.  
 5. Models with "R" at the end of the nomenclature are the traction drive type. Make sure to read page 8 for cautions on traction drive types.

## Dimension Tables

Figure in the bracket ( ) shows the dimension for types with brake.

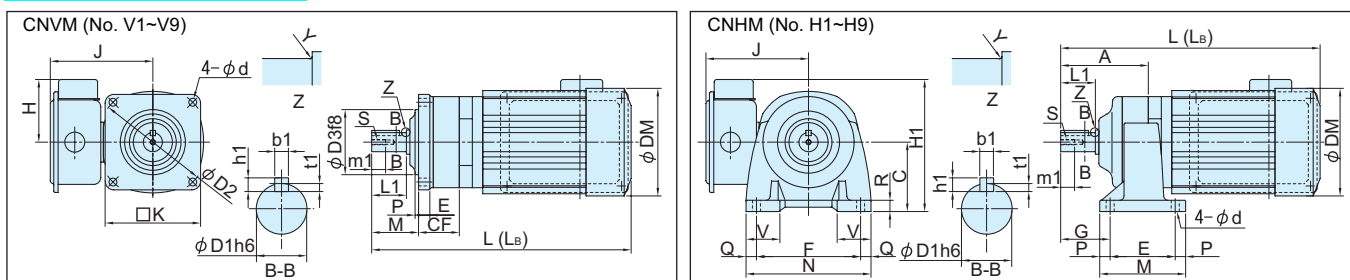

No.	Model	Main Body										Motor		Slow-speed Shaft Unit						Mass kg			
		CF	d	E	L	(L <sub>b</sub> )	M	P	D2	D3	H	K	J	DM	L1	m1	S	Y	D1		b1	h1	t1
V1	CNVM01-507R-CB(-B)-Reduction Ratio	28	9	13	276	308	46	4	130	75	72	110	118	124	32	16	M6	0.4	18	6	6	3.5	7.5 (9)
V2	CNVM01-506H-CB(-B)-Reduction Ratio	41	6.6	12	274	306	38	4	104	65	72	90	118	124	28	13	M5	0.5	16	5	5	3	7 (8.5)
V3	CNVM01-5077-CB(-B)-Reduction Ratio	42	9	13	286	318	46	4	130	75	72	110	118	124	32	16	M6	1	18	6	6	3.5	7.5 (8.5)
V4	CNVM01-5087-CB(-B)-Reduction Ratio	47	9	13	299	331	54	4	130	75	72	110	118	124	40	16	M6	1	22	6	6	3.5	7.5 (9)
V5	CNVM01-5097-CB(-B)-Reduction Ratio	63	11	14	342	374	66	4	165	95	72	140	118	124	50	19	M8	2	28	8	7	4	10 (11)
V6	CNVM01-5097DR-CB(-B)-Reduction Ratio	63	11	14	373	405	66	4	165	95	72	140	118	124	50	19	M8	2	28	8	7	4	11 (12)
V7	CNVM01-5107DR-CB(-B)-Reduction Ratio	79	11	16	603	435	74	4	190	110	(111)	160	118	124	58	22	M10	2	32	10	8	5	14 (16)
V8	CNVM01-5107DA-CB(-B)-Reduction Ratio	166	11	16	438	470	74	4	190	110	(120)	160	118	124	58	22	M10	2	32	10	8	5	15 (17)
V9	CNVM01-5127DA-CB(-B)-Reduction Ratio	198	14	20	504	536	93	6	235	150	(138)	205	118	124	75	28	M12	3	42	12	8	5	34 (35)

Note: Figures in the bracket ( ) for dimension H and H1 shows the height to the lifting piece of the unit.

No.	Model	Main Body										Motor		Slow-speed Shaft Unit						Mass kg							
		A	C	d	E	F	G	H1	L	(L <sub>b</sub> )	M	N	P	Q	R	V	J	DM	L1		S	Y	D1	b1	h1	t1	
H1	CNHM01-507R-CB(-B)-Reduction Ratio	74	71	9	75	120	49	143	276	308	99	144	12	12	12	50	118	124	32	16	M6	0.4	18	6	6	3.5	7.5 (9)
H2	CNHM01-506H-CB(-B)-Reduction Ratio	79	71	6.6	40	112	47	143	274	306	65	130	12.5	9	7	45	118	124	28	13	M5	0.5	16	5	5	3	7.5 (8.5)
H3	CNHM01-5077-CB(-B)-Reduction Ratio	88	71	9	75	120	49	143	286	318	99	144	12	12	12	39	118	124	32	16	M6	1	18	6	6	3.5	7.5 (9)
H4	CNHM01-5087-CB(-B)-Reduction Ratio	101	80	9	75	120	57	152	331	331	99	144	12	12	13	39	118	124	40	16	M6	1	22	6	6	3.5	8 (9)
H5	CNHM01-5097-CB(-B)-Reduction Ratio	129	90	11	90	120	75	162	342	374	120	180	15	15	14	44	118	124	50	19	M8	2	28	8	7	4	11 (12)
H6	CNHM01-5097DR-CB(-B)-Reduction Ratio	129	90	11	90	150	75	162	373	405	120	180	15	15	14	44	118	124	50	19	M8	2	28	8	7	4	12 (13)
H7	CNHM01-5107DR-CB(-B)-Reduction Ratio	153	100	11	115	170	83	(211)	403	435	145	200	15	15	16	52	118	124	58	22	M10	2	32	10	8	5	15 (17)
H8	CNHM01-5107DA-CB(-B)-Reduction Ratio	240	100	11	115	170	83	(220)	438	470	145	200	15	15	16	52	118	124	58	22	M10	2	32	10	8	5	16 (18)
H9	CNHM01-5127DA-CB(-B)-Reduction Ratio	291	120	14	150	210	102	(258)	504	536	190	260	20	25	20	65	118	124	75	28	M12	3	42	12	8	5	36 (37)

# Gearmotors, Flange Mount Type (CNVM), Foot Mount Type (CNHM)

## 0.2kW Single-Phase Motor

### Selection Tables

Reduction Ratio	Output Speed		Input Capacity - Frame Size - Suffix - Reduction Ratio	Output Torque Tout				Allowable Radial Load Pro				Dimension Table No.	
	r/min			N·m		kgf·m		N		kgf		CNVM	CNHM
	50Hz	60Hz		50Hz	60Hz	50Hz	60Hz	50Hz	60Hz	50Hz	60Hz		
3	483	583	02 - 507R - CB (-B) - 3	3.75	3.11	0.383	0.317	235	235	24.0	24.0	V1	H1
5	290	350	02 - 507R - CB (-B) - 5	6.26	5.18	0.638	0.528	392	392	40.0	40.0		
6	242	292	02 - 506H - CB (-B) - 6	7.51	6.22	0.765	0.634	540	540	55.0	55.0	V2	H2
8	181	219	02 - 506H - CB (-B) - 8	10.0	8.29	1.02	0.846	687	687	70.0	70.0		
11	132	159	02 - 506H - CB (-B) - 11	13.8	11.4	1.40	1.16	687	687	70.0	70.0		
13	112	135	02 - 506H - CB (-B) - 13	16.3	13.5	1.66	1.37	687	687	70.0	70.0		
15	96.7	117	02 - 506H - CB (-B) - 15	18.8	15.6	1.91	1.59	883	883	90.0	90.0		
17	85.3	103	02 - 506H - CB (-B) - 17	21.3	17.6	2.17	1.80	883	883	90.0	90.0	V3	H3
21	69.0	83.3	02 - 506H - CB (-B) - 21	26.3	21.8	2.68	2.22	1180	1180	120	120		
25	58.0	70.0	02 - 506H - CB (-B) - 25	31.3	25.9	3.19	2.64	1180	1180	120	120	V4	H4
29	50.0	60.3	02 - 5077 - CB (-B) - 29	36.3	30.1	3.70	3.07	1670	1670	170	170		
35	41.4	50.0	02 - 5077 - CB (-B) - 35	43.8	36.3	4.46	3.70	1670	1670	170	170		
43	33.7	40.7	02 - 5077 - CB (-B) - 43	53.8	44.6	5.49	4.54	1670	1670	170	170	V5	H5
51	28.4	34.3	02 - 5087 - CB (-B) - 51	63.8	52.9	6.51	5.39	2700	2700	275	275		
59	24.6	29.7	02 - 5087 - CB (-B) - 59	73.8	61.2	7.53	6.24	2700	2700	275	275	V6	H6
71	20.4	24.6	02 - 5097 - CB (-B) - 71	88.8	73.6	9.06	7.50	3430	3430	350	350		
87	16.7	20.1	02 - 5097 - CB (-B) - 87	109	90.2	11.1	9.20	3430	3430	350	350		
103	13.8	16.7	02 - 5097 - CB (-B) - 103	124	103	12.7	10.5	3430	3430	350	350	V7	H7
119	12.2	14.7	02 - 5097 - CB (-B) - 119	149	123	15.2	12.6	3430	3430	350	350		
145	10.0	12.1	02 - 5097DR - CB (-B) - 145	172	142	17.5	14.5	3430	3430	350	350	V8	H8
175	8.29	10.0	02 - 5097DR - CB (-B) - 175	207	172	21.1	17.5	3430	3430	350	350		
215	6.74	8.14	02 - 5107DR - CB (-B) - 215	255	211	26.0	21.5	4660	4660	475	475	V9	H9
255	5.69	6.86	02 - 5107DR - CB (-B) - 255	302	250	30.8	25.5	4660	4660	475	475		
295	4.92	5.93	02 - 5107DR - CB (-B) - 295	350	290	35.7	29.5	4660	4660	475	475		
355	4.08	4.93	02 - 5107DR - CB (-B) - 355	*340	*340	*34.7	*34.7	4660	4660	475	475	V9	H9
435	3.33	4.02	02 - 5117DR - CB (-B) - 435	516	427	52.6	43.6	5690	5690	580	580		
559	2.59	3.13	02 - 5127DA - CB (-B) - 559	663	549	67.6	56.0	7260	7260	740	740	V9	H9
649	2.23	2.70	02 - 5127DA - CB (-B) - 649	*762	638	*77.7	65.0	7260	7260	740	740		
731	1.98	2.39	02 - 5127DA - CB (-B) - 731	*711	*711	*72.5	*72.5	7260	7260	740	740		
841	1.72	2.08	02 - 5127DA - CB (-B) - 841	*665	*665	*67.8	*67.8	7260	7260	740	740	V9	H9
1003	1.45	1.74	02 - 5127DA - CB (-B) - 1003	*762	*762	*77.7	*77.7	7260	7260	740	740		

- Note: 1. Output motor speed is the representative value at 1450r/min (50Hz) and 1750r/min (60Hz). Refer to page 32 for details.  
 2. Radial load at slow speed shaft is the value at the middle of the slow speed shaft.  
 3. Be careful for the models with asterisk, "\*" They are models with torque limitation.  
 4. Figure in the bracket ( ) shows the dimension for types with brake.  
 5. Models with "R" at the end of the nomenclature are the traction drive type. Make sure to read page 8 for cautions on traction drive types.

### Dimension Tables

Figure in the bracket ( ) shows the dimension for types with brake.

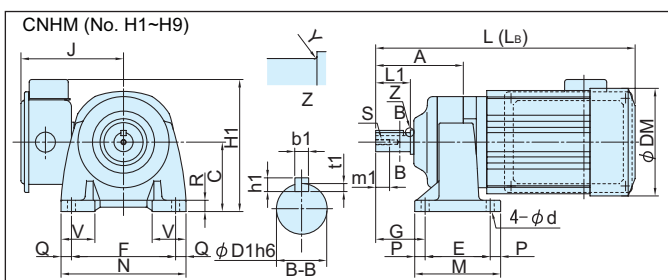
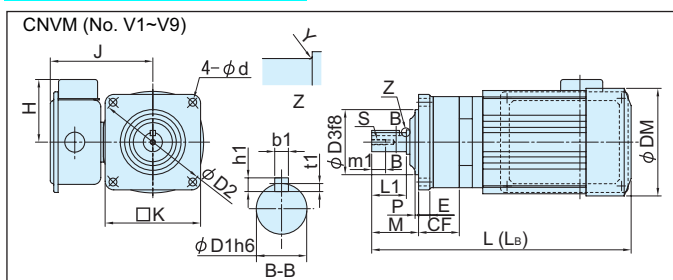

No.	Model	Main Body										Motor		Slow-speed Shaft Unit							Mass kg		
		CF	d	E	L (LB)	M	P	D2	D3	H	K	J	DM	L1	m1	S	Y	D1	b1	h1		t1	
V1	CNVM02-507R-CB(-B)-Reduction Ratio	28	9	13	176	308	46	4	130	75	72	110	118	124	32	16	M6	0.4	18	6	6	3.5	8.5 (10)
V2	CNVM02-506H-CB(-B)-Reduction Ratio	41	6.6	12	274	306	38	4	104	65	72	90	118	124	28	13	M5	0.5	16	5	5	3	8 (9.5)
V3	CNVM02-5077-CB(-B)-Reduction Ratio	42	9	13	286	318	46	4	130	75	72	110	118	124	32	16	M6	1	18	6	6	3.5	8.5 (9.5)
V4	CNVM02-5087-CB(-B)-Reduction Ratio	47	9	13	299	331	54	4	130	75	72	110	118	124	40	16	M6	1	22	6	6	3.5	8.5 (10)
V5	CNVM02-5097-CB(-B)-Reduction Ratio	63	11	14	342	374	66	4	165	95	72	140	118	124	50	19	M8	2	28	8	7	4	11 (12)
V6	CNVM02-5097DR-CB(-B)-Reduction Ratio	63	11	14	373	405	66	4	165	95	72	140	118	124	50	19	M8	2	28	8	7	4	12 (13)
V7	CNVM02-5107DR-CB(-B)-Reduction Ratio	79	11	16	403	435	74	4	190	110	(111)	160	118	124	58	22	M10	2	32	10	8	5	15 (17)
V8	CNVM02-5117DR-CB(-B)-Reduction Ratio	161	14	18	443	475	86	6	215	130	(128)	185	118	124	68	22	M10	3	38	10	8	5	26 (27)
V9	CNVM02-5127DA-CB(-B)-Reduction Ratio	198	14	20	504	536	93	6	235	150	(138)	205	118	124	75	28	M12	3	42	12	8	5	35 (36)

Note: Figures in the bracket ( ) for dimension H and H1 shows the height to the lifting piece of the unit.

No.	Model	Main Body										Motor		Slow-speed Shaft Unit							Mass kg						
		A	C	d	E	F	G	H1	L (LB)	M	N	P	Q	R	V	J	DM	L1	m1	S		Y	D1	b1	h1	t1	
H1	CNVM02-507R-CB(-B)-Reduction Ratio	74	71	9	75	120	49	143	176	308	99	144	12	12	12	50	118	124	32	16	M6	0.4	18	6	6	3.5	8.5 (10)
H2	CNVM02-506H-CB(-B)-Reduction Ratio	79	71	6.6	40	112	47	143	274	306	65	130	12.5	9	7	45	118	124	28	13	M5	0.5	16	5	5	3	8.5 (9.5)
H3	CNVM02-5077-CB(-B)-Reduction Ratio	88	71	9	75	120	49	143	286	318	99	144	12	12	12	39	118	124	32	16	M6	1	18	6	6	3.5	9 (10)
H4	CNVM02-5087-CB(-B)-Reduction Ratio	101	80	9	75	120	57	152	299	331	99	144	12	12	13	39	118	124	40	16	M6	1	22	6	6	3.5	9 (10)
H5	CNVM02-5097-CB(-B)-Reduction Ratio	129	90	11	90	120	75	162	342	374	120	180	15	15	14	44	118	124	50	19	M8	2	28	8	7	4	12 (13)
H6	CNVM02-5097DR-CB(-B)-Reduction Ratio	129	90	11	90	150	75	162	373	405	120	180	15	15	14	44	118	124	50	19	M8	2	28	8	7	4	13 (14)
H7	CNVM02-5107DR-CB(-B)-Reduction Ratio	153	100	11	115	170	83	(211)	403	435	145	200	15	15	16	52	118	124	58	22	M10	2	32	10	8	5	16 (18)
H8	CNVM02-5117DR-CB(-B)-Reduction Ratio	247	120	14	135	190	95	(248)	443	475	175	230	20	20	18	60	118	124	68	22	M10	3	38	10	8	5	27 (28)
H9	CNVM02-5127DA-CB(-B)-Reduction Ratio	291	120	14	150	210	102	(258)	504	536	190	260	20	25	20	65	118	124	75	28	M12	3	42	12	8	5	37 (38)









# Gearmotors, Flange Mount Type (CNVM), Foot Mount Type (CNHM) 0.4kW Three-Phase Motor for Inverter

## Selection Tables

Reduction Ratio	Output Speed			Input Capacity Symbol	Frame Size	Suffix	Reduction Ratio	Output Torque $T_{out}$		Allowable Radial Load $P_{ro}$		Dimension Table No.	
	r/min		Max. Allowable Speed (120Hz)					N·m	kgf·m	N	kgf	CNVM	CNHM
	6Hz	60Hz											
Nomenclature details: p. 3													
3	58.3	583	1167	05	- 508R	- AV	(-B) - 3	6.22	0.634	603	62.0	V1	H1
5	35.0	350	700	05	- 508R	- AV	(-B) - 5	10.4	1.06	1000	102		
6	29.2	292	584	05	- 5087	- AV	(-B) - 6	12.4	1.27	1000	102		
8	21.9	219	438	05	- 5087	- AV	(-B) - 8	16.6	1.69	1000	102		
11	15.9	159	318	05	- 5087	- AV	(-B) - 11	22.8	2.33	1470	150		
13	13.5	135	270	05	- 5087	- AV	(-B) - 13	27.0	2.75	1470	150	V2	H2
15	11.7	117	234	05	- 5087	- AV	(-B) - 15	31.1	3.17	1600	163		
17	10.3	103	206	05	- 5087	- AV	(-B) - 17	35.3	3.59	1810	185		
21	8.33	83.3	167	05	- 5087	- AV	(-B) - 21	43.5	4.44	2250	229		
25	7.00	70.0	140	05	- 5087	- AV	(-B) - 25	51.8	5.28	2680	273		
29	6.03	60.3	121	05	- 5087	- AV	(-B) - 29	60.1	6.13	2700	275	V3	H3
35	5.00	50.0	100	05	- 5087	- AV	(-B) - 35	72.6	7.40	2700	275		
43	4.07	40.7	81.4	05	- 5097	- AV	(-B) - 43	89.2	9.09	3430	350		
51	3.43	34.3	68.6	05	- 5097	- AV	(-B) - 51	106	10.8	3430	350		
59	2.97	29.7	59.4	05	- 5097	- AV	(-B) - 59	122	12.5	3430	350		
71	2.46	24.6	49.2	05	- 5097	- AV	(-B) - 71	147	15.0	3430	350	V4	H4
87	2.01	20.1	40.2	05	- 5107	- AV	(-B) - 87	180	18.4	4660	475		
103	1.67	16.7	33.4	05	- 5107	- AV	(-B) - 103	206	21.0	4660	475		
119	1.47	14.7	29.4	05	- 5107	- AV	(-B) - 119	247	25.2	4660	475	V5	H5
145	1.21	12.1	24.2	05	- 5127DR	- AV	(-B) - 145	285	29.0	7260	740		
175	1.00	10.0	20.0	05	- 5127DR	- AV	(-B) - 175	344	35.0	7260	740		
215	0.81	8.1	16.3	05	- 5127DR	- AV	(-B) - 215	422	43.1	7260	740		
255	0.686	6.86	13.7	05	- 5127DR	- AV	(-B) - 255	501	51.1	7260	740		
295	0.593	5.93	11.9	05	- 5127DR	- AV	(-B) - 295	580	59.1	7260	740	V6	H6
355	0.493	4.93	9.86	05	- 5127DR	- AV	(-B) - 355	*604	*61.5	7260	740		
435	0.402	4.02	8.04	05	- 5127DR	- AV	(-B) - 435	*774	*78.9	7260	740		
559	0.313	3.13	6.26	05	- 5127DA	- AV	(-B) - 559	*711	*72.5	7260	740		
649	0.270	2.70	5.40	05	- 5127DA	- AV	(-B) - 649	*762	*77.7	7260	740		
731	0.239	2.39	4.78	05	- 5127DA	- AV	(-B) - 731	*711	*72.5	7260	740		

- Note:
- Output motor speed is the representative value at 1750r/min (60Hz) and 175r/min (6Hz). Refer to page 32 for details.
  - Radial load at low speed shaft is the value at the middle of the slow speed shaft.
  - Be careful for the models with asterisk, "\*" They are models with torque limitation.
  - Constant torque operation (continuous operation) is possible when the unit is used with inverter motor in the frequency range 6Hz~60Hz. Operation with frequency range over base frequency (60Hz) will be constant output.
  - The unit will show reduced torque characteristics when the general inverter is used for operation with inverter.
  - Constant torque operation is possible using general motor when Sumitomo inverter (HF-320 or HF-320 $\alpha$ ) is used for sensorless operation. Refer to the specific catalog for details.
  - Consult us when using the unit with frequency over 60Hz.
  - Models with "R" at the end of the nomenclature are the traction drive type. Make sure to read page 8 for cautions on traction drive types.

## Dimension Tables

Figure in the bracket ( ) shows the dimension for types with brake.

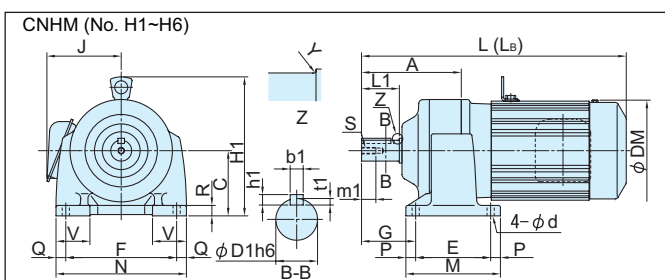
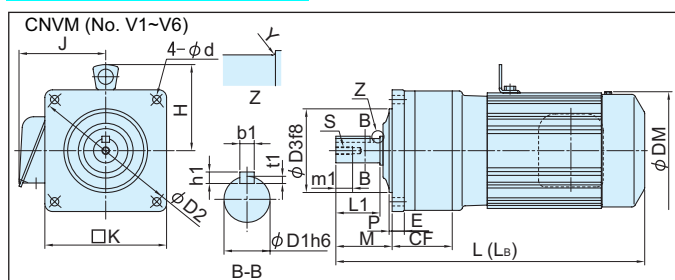

No.	Model	Main Body										Motor		Slow-speed Shaft Unit						Mass kg			
		CF	d	E	L	(L <sub>b</sub> )	M	P	D2	D3	H	K	J	DM	L1	m1	S	Y	D1		b1	h1	t1
V1	CNVM05-508R-AV(-B)-Reduction Ratio	57	9	13	353	396	54	4	130	75	-	113	114	155	40	16	M6	0.4	22	6	6	3.5	13 (16)
V2	CNVM05-5087-AV(-B)-Reduction Ratio	47	9	13	350	393	54	4	130	75	-	110	114	155	40	16	M6	1	22	6	6	3.5	11 (14)
V3	CNVM05-5097-AV(-B)-Reduction Ratio	63	11	14	378	421	66	4	165	95	-	140	114	155	50	19	M8	2	28	8	7	4	13 (16)
V4	CNVM05-5107-AV(-B)-Reduction Ratio	79	11	16	406	449	74	4	190	110	113	160	114	155	58	22	M10	2	32	10	8	5	17 (19)
V5	CNVM05-5127DR-AV(-B)-Reduction Ratio	172	14	20	507	550	93	6	235	150	138	205	114	155	75	28	M12	3	42	12	8	5	37 (40)
V6	CNVM05-5127DA-AV(-B)-Reduction Ratio	198	14	20	540	583	93	6	235	150	138	205	114	155	75	28	M12	3	42	12	8	5	37 (39)

No.	Model	Main Body										Motor		Slow-speed Shaft Unit						Mass kg							
		A	C	d	E	F	G	H1	L	(L <sub>b</sub> )	M	N	P	Q	R	V	J	DM	L1		m1	S	Y	D1	b1	h1	t1
H1	CNVM05-508R-AV(-B)-Reduction Ratio	111	80	9	75	120	57	193	353	396	99	144	12	12	13	50	114	155	40	16	M6	0.4	22	6	6	3.5	13 (16)
H2	CNVM05-5087-AV(-B)-Reduction Ratio	101	80	9	75	120	57	193	350	393	99	144	12	12	13	39	114	155	40	16	M6	1	22	6	6	3.5	11 (14)
H3	CNVM05-5097-AV(-B)-Reduction Ratio	129	90	11	90	150	75	203	378	421	120	180	15	15	14	44	114	155	50	19	M8	2	28	8	7	4	14 (17)
H4	CNVM05-5107-AV(-B)-Reduction Ratio	153	100	11	115	170	83	213	406	449	145	200	15	15	16	52	114	155	58	22	M10	2	32	10	8	5	18 (20)
H5	CNVM05-5127DR-AV(-B)-Reduction Ratio	265	120	14	150	210	102	258	507	550	190	260	20	25	20	65	114	155	75	28	M12	3	42	12	8	5	37 (40)
H6	CNVM05-5127DA-AV(-B)-Reduction Ratio	291	120	14	150	210	102	258	540	583	190	260	20	25	20	65	114	155	75	28	M12	3	42	12	8	5	39 (42)



# Gearmotors, Flange Mount Type (CNVM), Foot Mount Type (CNHM) 0.75kW Three-Phase Motor for Inverter

## Selection Tables

Reduction Ratio	Output Speed r/min			Input Capacity Symbol	Frame Size	Suffix	Reduction Ratio	Output Torque Tout		Allowable Radial Load Pro		Dimension Table No.	
	6Hz	60Hz	Max. Allowable Speed (120Hz)					N·m	kgf·m	N	kgf	CNVM	CNHM
	60Hz	60Hz	(120Hz)					60Hz	60Hz	60Hz	60Hz		
3	58.3	583	1167 (60Hz)	1	- 509R	- AV (-B)	3	11.7	1.19	948	97.0	V1	H1
5	35.0	350	700 (60 Hz)	1	- 509R	- AV (-B)	5	19.4	1.98	1580	161		
6	29.2	292	584	1	- 5097	- AV (-B)	6	23.3	2.38	1960	200	V2	H2
8	21.9	219	438	1	- 5097	- AV (-B)	8	31.1	3.17	2450	250		
11	15.9	159	318	1	- 5097	- AV (-B)	11	42.8	4.36	2450	250		
13	13.5	135	270	1	- 5097	- AV (-B)	13	50.5	5.15	2750	280		
15	11.7	117	234	1	- 5097	- AV (-B)	15	58.3	5.95	2850	290		
17	10.3	103	206	1	- 5097	- AV (-B)	17	66.1	6.74	3240	330		
21	8.33	83.3	167	1	- 5097	- AV (-B)	21	81.7	8.32	3430	350		
25	7.00	70.0	140	1	- 5097	- AV (-B)	25	97.2	9.91	3430	350		
29	6.03	60.3	121	1	- 5097	- AV (-B)	29	113	11.5	3430	350	V3	H3
35	5.00	50.0	100	1	- 5097	- AV (-B)	35	136	13.9	3430	350		
43	4.07	40.7	81.4	1	- 5097	- AV (-B)	43	167	17.0	3430	350	V4	H4
51	3.43	34.3	68.6	1	- 5107	- AV (-B)	51	198	20.2	4660	475		
59	2.97	29.7	59.4	1	- 5107	- AV (-B)	59	229	23.4	4660	475		
71	2.46	24.6	49.2	1	- 5107	- AV (-B)	71	276	28.1	4660	475		
87	2.01	20.1	40.2	1	- 5107	- AV (-B)	87	338	34.5	4660	475	V4	H4
105	1.67	16.7	33.4	1	- 5127DS	- AV (-B)	105	387	39.4	7260	740		
125	1.40	14.0	29.4	1	- 5127DS	- AV (-B)	125	460	46.9	7260	740		
145	1.21	12.1	24.2	1	- 5127DS	- AV (-B)	145	534	54.4	7260	740	V4	H4
175	1.00	10.0	20.0	1	- 5127DS	- AV (-B)	175	645	65.7	7260	740		
215	0.814	8.14	16.3	1	- 5127DS	- AV (-B)	215	*711	*72.5	7260	740		
255	0.686	6.86	13.7	1	- 5127DS	- AV (-B)	255	*740	*75.4	7260	740	V4	H4
295	0.593	5.93	11.9	1	- 5127DS	- AV (-B)	295	*762	*77.7	7260	740		

- Note: 1. Output motor speed is the representative value at 1750r/min (60Hz) and 175r/min (6Hz). Refer to page 32 for details.  
 2. Radial load at slow speed shaft is the value at the middle of the slow speed shaft.  
 3. Be careful for the models with asterisk, "\*" They are models with torque limitation.  
 4. Constant torque operation (continuous operation) is possible when the unit is used with inverter motor in the frequency range 6Hz~60Hz. Operation with frequency range over base frequency (60Hz) will be constant output.  
 5. The unit will show reduced torque characteristics when the general inverter is used for operation with inverter.  
 6. Constant torque operation is possible using general motor when Sumitomo inverter (HF-320 or HF-320α) is used for sensorless operation. Refer to the specific catalog for details.  
 7. Consult us when using the unit with frequency over 60Hz.  
 8. Models with "R" and "S" at the end of the nomenclature are the traction drive type. Make sure to read page 8 for cautions on traction drive types.

## Dimension Tables

Figure in the bracket ( ) shows the dimension for types with brake.

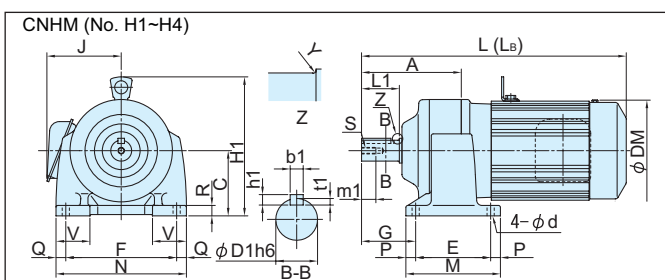
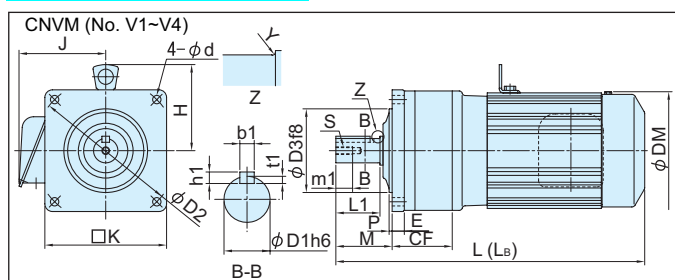

No.	Model	Main Body										Motor		Slow-speed Shaft Unit						Mass kg			
		CF	d	E	L	(L <sub>B</sub> )	M	P	D2	D3	H	K	J	DM	L1	m1	S	Y	D1		b1	h1	t1
V1	CNVM1-509R-AV(-B)-Reduction Ratio	79	11	14	415	477	66	4	165	95	120	142	119	167	50	19	M8	0.4	28	8	7	4	21 (26)
V2	CNVM1-5097-AV(-B)-Reduction Ratio	63	11	14	410	472	66	4	165	95	120	140	119	167	50	19	M8	2	28	8	7	4	17 (22)
V3	CNVM1-5107-AV(-B)-Reduction Ratio	79	11	16	437	499	74	4	190	110	120	160	119	167	58	22	M10	2	32	10	8	5	21 (26)
V4	CNVM1-5127DS-AV(-B)-Reduction Ratio	185	14	20	548	610	93	6	235	150	138	205	119	167	75	28	M12	3	42	12	8	5	42 (47)

No.	Model	Main Body										Motor		Slow-speed Shaft Unit						Mass kg							
		A	C	d	E	F	G	H1	L	(L <sub>B</sub> )	M	N	P	Q	R	V	J	DM	L1		m1	S	Y	D1	b1	h1	t1
H1	CNHM1-509R-AV(-B)-Reduction Ratio	145	90	11	90	150	75	210	415	477	120	180	15	15	14	70	119	167	50	19	M8	0.4	28	8	7	4	21 (26)
H2	CNHM1-5097-AV(-B)-Reduction Ratio	129	90	11	90	150	75	210	410	472	120	180	15	15	14	44	119	167	50	19	M8	2	28	8	7	4	18 (23)
H3	CNHM1-5107-AV(-B)-Reduction Ratio	153	100	11	115	170	83	220	437	499	145	200	15	15	16	52	119	167	58	22	M10	2	32	10	8	5	21 (27)
H4	CNHM1-5127DS-AV(-B)-Reduction Ratio	278	120	14	150	210	102	258	548	610	190	260	20	25	20	65	119	167	75	28	M12	3	42	12	8	5	43 (48)

# Gearmotors, Flange Mount Type (CNVM), Foot Mount Type (CNHM) 1.5kW Three-Phase Motor for Inverter

## Selection Tables

Reduction Ratio	Output Speed r/min			Input Capacity - Symbol	Frame Size	Suffix	Reduction Ratio	Output Torque Tout		Allowable Radial Load Pro		Dimension Table No.			
	6Hz	60Hz	Max. Allowable Speed (120Hz)					N·m	kgf·m	N	kgf	CNVM	CNHM		
	60Hz	60Hz	60Hz					60Hz	60Hz						
3	58.3	583	1167 (60Hz)	CNVM (Flange Mount) CNHM (Foot Mount)	Nomenclature details: p. 3			23.3	2.38	948	97.0	V1	H1		
5	35.0	350	700 (60Hz)					38.9	3.96	1580	161				
6	29.2	292	584					2	- 5097 - AV (-B) - 6	46.7	4.76	1960	200	V2	H2
8	21.9	219	438					2	- 5097 - AV (-B) - 8	62.2	6.34	2450	250		
11	15.9	159	318					2	- 5097 - AV (-B) - 11	85.5	8.72	2450	250		
13	13.5	135	270					2	- 5097 - AV (-B) - 13	101	10.3	2750	280		
15	11.7	117	234					2	- 5097 - AV (-B) - 15	117	11.9	2850	290	V3	H3
17	10.3	103	206					2	- 5097 - AV (-B) - 17	132	13.5	3240	330		
21	8.33	83.3	167					2	- 5097 - AV (-B) - 21	163	16.6	3430	350		
25	7.00	70.0	140					2	- 5107 - AV (-B) - 25	194	19.8	4660	475		
29	6.03	60.3	121					2	- 5107 - AV (-B) - 29	226	23.0	4660	475	V4	H4
35	5.00	50.0	100					2	- 5107 - AV (-B) - 35	272	27.7	4660	475		
43	4.07	40.7	81.4					2	- 5107 - AV (-B) - 43	334	34.1	4660	475		
51	3.43	34.3	68.6					2	- 5117 - AV (-B) - 51	397	40.4	5690	580		
59	2.97	29.7	59.4					2	- 5117 - AV (-B) - 59	459	46.8	5690	580	V5	H5
71	2.46	24.6	49.2					2	- 5127 - AV (-B) - 71	552	56.3	7260	740		
87	2.01	20.1	40.2					2	- 5127 - AV (-B) - 87	677	69.0	7260	740		

- Note: 1. Output motor speed is the representative value at 1750r/min (60Hz) and 175r/min (6Hz). Refer to page 32 for details.  
 2. Radial load at slow speed shaft is the value at the middle of the slow speed shaft.  
 3. Constant torque operation (continuous operation) is possible when the unit is used with inverter motor in the frequency range 6Hz-60Hz. Operation with frequency range over base frequency (60Hz) will be constant output.  
 4. The unit will show reduced torque characteristics when the general inverter is used for operation with inverter.  
 5. Constant torque operation is possible using general motor when Sumitomo inverter (HF-320 or HF-320α) is used for sensorless operation. Refer to the specific catalog for details.  
 6. Consult us when using the unit with frequency over 60Hz.  
 7. Models with "R" at the end of the nomenclature are the traction drive type. Make sure to read page 8 for cautions on traction drive types.

## Dimension Tables

Figure in the bracket ( ) shows the dimension for types with brake.

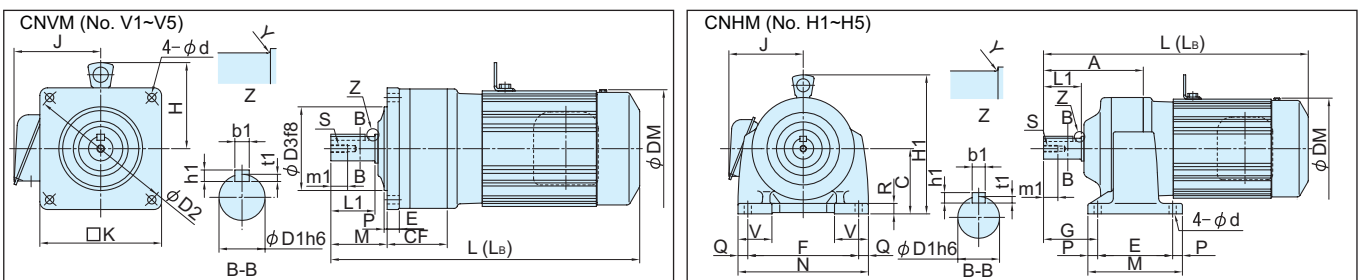

No.	Model	Main Body										Motor		Slow-speed Shaft Unit							Mass kg		
		CF	d	E	L	(Lb)	M	P	D2	D3	H	K	J	DM	L1	m1	S	Y	D1	b1		h1	t1
V1	CNVM2-509R-AV(-B)-Reduction Ratio	79	11	14	435	498	66	4	165	95	126	142	126	180	50	19	M8	0.4	28	8	7	4	25 (32)
V2	CNVM2-5097-AV(-B)-Reduction Ratio	63	11	14	430	493	66	4	165	95	126	140	126	180	50	19	M8	2	28	8	7	4	23 (30)
V3	CNVM2-5107-AV(-B)-Reduction Ratio	79	11	16	456	519	74	4	190	110	126	160	126	180	58	22	M10	2	32	10	8	5	25 (31)
V4	CNVM2-5117-AV(-B)-Reduction Ratio	88	14	18	490	553	86	6	215	130	126	185	126	180	68	22	M10	3	38	10	8	5	36 (42)
V5	CNVM2-5127-AV(-B)-Reduction Ratio	93	14	20	502	565	93	6	235	150	126	205	126	180	75	28	M12	3	42	12	8	5	44 (50)

No.	Model	Main Body										Motor		Slow-speed Shaft Unit							Mass kg						
		A	C	d	E	F	G	H1	L	(Lb)	M	N	P	Q	R	V	J	DM	L1	m1		S	Y	D1	b1	h1	t1
H1	CNVM2-509R-AV(-B)-Reduction Ratio	145	90	11	90	150	75	216	435	498	120	180	15	15	14	70	126	180	50	19	M8	0.4	28	8	7	4	25 (32)
H2	CNVM2-5097-AV(-B)-Reduction Ratio	129	90	11	90	150	75	216	430	493	120	180	15	14	44	126	180	50	19	M8	2	28	8	7	4	24 (31)	
H3	CNVM2-5107-AV(-B)-Reduction Ratio	153	100	11	115	170	83	226	456	519	145	200	15	15	16	52	126	180	58	22	M10	2	32	10	8	5	26 (32)
H4	CNVM2-5117-AV(-B)-Reduction Ratio	174	120	14	135	190	95	246	490	553	175	230	20	20	18	60	126	180	68	22	M10	3	38	10	8	5	39 (48)
H5	CNVM2-5127-AV(-B)-Reduction Ratio	186	120	14	150	210	102	246	502	565	190	260	20	25	20	65	126	180	75	28	M12	3	42	12	8	5	46 (52)

# Gearmotors, Flange Mount Type (CNVM), Foot Mount Type (CNHM)

## 2.2kW Three-Phase Motor for Inverter

### Selection Tables

Reduction Ratio	Output Speed r/min			Input Capacity - Symbol	Frame Size	Suffix	Reduction Ratio	Output Torque Tout		Allowable Radial Load Pro		Dimension Table No.	
	6Hz	60Hz	Max. Allowable Speed (120Hz)					N·m	kgf·m	N	kgf	CNVM	CNHM
	60Hz	60Hz	60Hz					60Hz	60Hz				
3	58.3	583	1167	3 - 510R - AV (-B) - 3 3 - 510R - AV (-B) - 5 3 - 5107 - AV (-B) - 8 3 - 5107 - AV (-B) - 11 3 - 5107 - AV (-B) - 13 3 - 5107 - AV (-B) - 15 3 - 5107 - AV (-B) - 17 3 - 5107 - AV (-B) - 21 3 - 5117 - AV (-B) - 25 3 - 5117 - AV (-B) - 29 3 - 5117 - AV (-B) - 35 3 - 5117 - AV (-B) - 43 3 - 5127 - AV (-B) - 51 3 - 5127 - AV (-B) - 59	510R	- AV (-B) -	3	34.2	3.49	1220	124	V1	H1
5	35.0	350	700					57.0	5.81	2030	207		
8	21.9	219	438					91.2	9.30	2970	303		
11	15.9	159	318					125	12.8	2970	303		
13	13.5	135	270					148	15.1	3510	358		
15	11.7	117	234					171	17.4	4050	413		
17	10.3	103	206					194	19.8	4590	468		
21	8.33	83.3	167					240	24.4	4660	475		
25	7.00	70.0	140					285	29.1	5690	580		
29	6.03	60.3	121					331	33.7	5690	580		
35	5.00	50.0	100	399	40.7	5690	580						
43	4.07	40.7	81.4	490	50.0	5690	580						
51	3.43	34.3	68.6	582	59.3	7260	740						
59	2.97	29.7	59.4	673	68.6	7260	740						

- Note: 1. Output motor speed is the representative value at 1750r/min (60Hz) and 175r/min (6Hz). Refer to page 32 for details.  
 2. Radial load at slow speed shaft is the value at the middle of the slow speed shaft.  
 3. Constant torque operation (continuous operation) is possible when the unit is used with inverter motor in the frequency range 6Hz~60Hz. Operation with frequency range over base frequency (60Hz) will be constant output.  
 4. The unit will show reduced torque characteristics when the general inverter is used for operation with inverter.  
 5. Constant torque operation is possible using general motor when Sumitomo inverter (HF-320 or HF-320α) is used for sensorless operation. Refer to the specific catalog for details.  
 6. Consult us when using the unit with frequency over 60Hz.  
 7. Models with "R" at the end of the nomenclature are the traction drive type. Make sure to read page 8 for cautions on traction drive types.

### Dimension Tables

Figure in the bracket ( ) shows the dimension for types with brake.

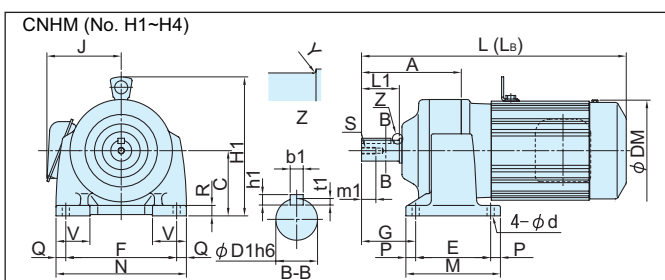
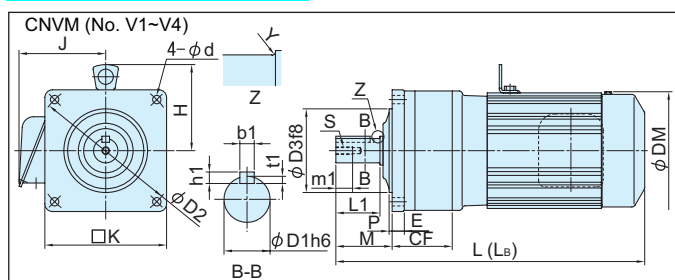

No.	Model	Main Body										Motor		Slow-speed Shaft Unit							Mass kg		
		CF	d	E	L (L <sub>b</sub> )	M	P	D2	D3	H	K	J	DM	L1	m1	S	Y	D1	b1	h1		t1	
V1	CNVM3-510R-AV(-B)-Reduction Ratio	92	11	16	515	587	74	4	190	110	146	160	147	222	58	22	M10	0.4	32	10	8	5	38 (48)
V2	CNVM3-5107-AV(-B)-Reduction Ratio	79	11	16	515	587	74	4	190	110	146	160	147	222	58	22	M10	2	32	10	8	5	37 (47)
V3	CNVM3-5117-AV(-B)-Reduction Ratio	88	14	18	516	588	86	6	215	130	146	185	147	222	68	22	M10	3	38	10	8	5	45 (55)
V4	CNVM3-5127-AV(-B)-Reduction Ratio	93	14	20	528	600	93	6	235	150	146	205	147	222	75	28	M12	3	42	12	8	5	54 (63)

No.	Model	Main Body										Motor		Slow-speed Shaft Unit							Mass kg						
		A	C	d	E	F	G	H1	L (L <sub>b</sub> )	M	N	P	Q	R	V	J	DM	L1	m1	S		Y	D1	b1	h1	t1	
H1	CNHM3-510R-AV(-B)-Reduction Ratio	166	100	11	115	170	83	246	515	587	145	200	15	15	16	75	147	222	58	22	M10	0.4	32	10	8	5	38 (48)
H2	CNHM3-5107-AV(-B)-Reduction Ratio	153	100	11	115	170	83	246	515	587	145	200	15	15	16	52	147	222	58	22	M10	2	32	10	8	5	38 (48)
H3	CNHM3-5117-AV(-B)-Reduction Ratio	174	120	14	135	190	95	266	516	588	175	230	20	20	18	60	147	222	68	22	M10	3	38	10	8	5	48 (57)
H4	CNHM3-5127-AV(-B)-Reduction Ratio	186	120	14	150	210	102	266	528	600	190	260	20	25	20	65	147	222	75	28	M12	3	42	12	8	5	56 (65)

# Technical Data

## Gearmotor's Moment of Inertia $J \cdot GD^2$ (Motor Shaft Equivalent)

Unit: J (Moment of Inertia)  $[10^{-4}kg \cdot m^2]$   $GD^2$   $[10^{-4}kgf \cdot m^2]$

Motor Type		90W		0.1kW (F-56L) <sup>Note 1</sup>		0.1kW (F-63S) <sup>Note 1</sup>		0.2kW	
		J	GD <sup>2</sup>	J	GD <sup>2</sup>	J	GD <sup>2</sup>	J	GD <sup>2</sup>
Three-Phase Motor Indoor Type	Without Brake	1.32	5.29	1.52	6.07	3.48	13.9	5.28	21.1
	With Brake	1.40	5.59	1.52	6.08	3.73	14.9	5.78	23.1
Single-Phase Motor Indoor Type	Without Brake	1.97	7.89	-	-	5.23	20.9	6.78	27.1
	With Brake	2.05	8.19	-	-	5.73	22.9	7.03	28.1
Motor for Inverter Indoor Type	Without Brake	-	-	-	-	5.23	20.9	6.78	27.1
	With Brake	-	-	-	-	5.73	22.9	7.03	28.1

Motor Type		0.25kW		0.4kW		0.55kW		0.75kW	
		J	GD <sup>2</sup>	J	GD <sup>2</sup>	J	GD <sup>2</sup>	J	GD <sup>2</sup>
Three-Phase Motor Indoor Type	Without Brake	5.44	21.8	6.95	27.8	10.8	43.2	13.1	52.3
	With Brake	5.94	23.8	7.20	28.8	11.8	47.2	14.1	56.3
Single-Phase Motor Indoor Type	Without Brake	-	-	12.7	50.7	-	-	-	-
	With Brake	-	-	13.7	54.7	-	-	-	-
Motor for Inverter Indoor Type	Without Brake	-	-	12.7	50.7	-	-	24.1	96.3
	With Brake	-	-	13.7	54.7	-	-	26.3	105

Motor Type		1.1kW		1.5kW		2.2kW	
		J	GD <sup>2</sup>	J	GD <sup>2</sup>	J	GD <sup>2</sup>
Three-Phase Motor Indoor Type	Without Brake	21.3	85.3	24.1	96.3	37.1	149
	With Brake	23.6	94.3	26.3	105	41.1	165
Single-Phase Motor Indoor Type	Without Brake	-	-	-	-	-	-
	With Brake	-	-	-	-	-	-
Motor for Inverter Indoor Type	Without Brake	-	-	36.1	144	88.6	355
	With Brake	-	-	40.1	160	99.6	399

Note 1: Indoor type Without brake

0.1kW reducer 1/6-1/51: motor frame size F-56L

0.1kW reducer 1/3, 1/5, 1/59-1/1003: motor frame size F-63S

Indoor type With brake

0.1kW reducer 1/6-1/51: motor frame size F-56L

0.1kW reducer 1/3, 1/5, 1/59-1/1003: motor frame size F-63S

# Slow Speed Shaft Direction, Actual Reduction Ratio

## Slow Speed Shaft Direction

### 1. Gearmotor

Slow speed shaft direction when wired as shown on page 35.

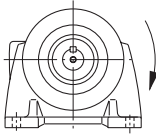
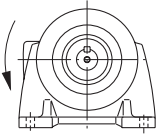
When the wires are connected as shown on page 35, the motor shaft turns in the right direction, viewed from the non-loading side. At that time, the slow speed shaft rotary direction is as shown by the arrow in the figures.		
Frame Size	5067, 506H, 5077, 5087, 5097, 5107, 5117, 5127, 5097DR, 5107DR, 5117DR, 5127DR, 5127DS	507R, 508R, 509R, 510R, 5107DA, 5127DA
Rotational Direction of Slow Speed Shaft (Viewed from the load side)		

- Switch wire R and T when for reverse rotation of a standard three-phase motor.
- Change over the switch SW (as in page 35) to reverse the rotation of a 90W single-phase motor.
- Stop the motor and switch wire X and Y for reverse the rotation of a 0.1 - 0.4kW single-phase motor.

### 2. Reducer

Frame Size	5067, 506H, 5077, 5087, 5097, 5107, 5117, 5127, 5097DR, 5107DR, 5117DR, 5127DR, 5127DS	507R, 508R, 509R, 510R, 5107DA, 5127DA
Rotational Direction of Slow Speed Shaft	Reverse direction from the input shaft.	Same direction as the input shaft

\*Consult us for details on the selection and dimensions of a reducer.

## Actual Reduction Ratio

Reduction ratio shown for each model (nominal reduction ratio) basically represents the actual reduction ratio. However, some conditions differ according to the frame size. Refer to the table below.

Frame Size	5067 5107	506H 5117	5077 5127	5087 5107DA	5097 5127DA
Actual Reduction Ratio	All values should be integral, and the reduction ratio (nominal reduction ratio) shown for each model represents the actual reduction ratio.				

Frame Size	507R 5107DR	508R 5117DR	509R 5127DR	510R 5127DS	5097DR
Actual Reduction Ratio	The traction drive has been used in the decelerating unit and the actual reduction ratio varies slightly, depending on the driving load condition.  Actual Reduction Gear Ratio = Nominal Reduction Gear Ratio x (0.997 to 1.003)				

## Lubrication

### Standard Lubrication

- Long-life grease packed in the gear section does not require top-up for an extended period of time. However, you can extend the life of the unit by changing grease after every 20,000 hours of operation or every 3 to 5 years.
- Request the overhaul with our service office, as overhauling a gearmotor requires experienced service personnel.

Note: Regarding oil seal

Oil seal has limited lifetime. Sealing effect may lower by natural degradation or abrasion by prolonged use. Seal life may vary depending on operation condition and ambient condition of the reducer. Oil seal change every 1~3 years is recommended for normal operation (uniform load, 10 hours/day, at normal temperature).

# Technical Data

## Characteristics for Global Motor

### 1. Three-Phase Motor (Without Brake/With Brake, Indoor)

#### 1) 200V Class

Poles		4P														
Power		200V-50Hz					200V-60Hz					220V-60Hz				
Output [kW]	Motor Frame Size	Rated Current [A]	Max. Torque [%]	Starting Torque [%]	Starting Current [A]	Speed [r/min]	Rated Current [A]	Max. Torque [%]	Starting Torque [%]	Starting Current [A]	Speed [r/min]	Rated Current [A]	Max. Torque [%]	Starting Torque [%]	Starting Current [A]	Speed [r/min]
0.09	F-56L	0.65	264	254	2.1	1370	0.56	230	204	1.9	1640	0.57	289	271	2.1	1680
0.1	F-56L <sup>Note 1</sup>	0.69	235	226	2.1	1350	0.60	205	182	1.9	1620	0.60	257	242	2.1	1660
0.1	F-63S <sup>Note 1</sup>	0.69	265	281	2.7	1420	0.60	236	245	2.5	1700	0.62	285	297	2.8	1720
0.2	F-63M	1.24	232	233	4.6	1410	1.09	210	207	4.2	1700	1.09	254	250	4.8	1720
0.25	F-63M	1.40	205	225	5.2	1380	1.28	177	189	4.6	1660	1.24	228	251	5.2	1690
0.4	F-71M	2.35	237	237	9.1	1410	2.05	210	210	8.3	1700	2.02	257	257	9.4	1730
0.55	F-80S	2.82	219	227	11.2	1410	2.58	190	189	10.5	1680	2.47	237	240	11.7	1710
0.75	F-80M	3.88	234	215	16.0	1420	3.43	211	190	15.1	1720	3.35	253	242	16.8	1740
1.1	F-90S	5.33	246	225	26.5	1420	4.86	210	194	24.4	1690	4.65	263	246	27.2	1720
1.5	F-90L	6.97	233	224	34.1	1430	6.29	205	192	31.2	1710	6.00	250	243	34.9	1730
2.2	F-100L	9.74	268	255	52.0	1430	8.90	229	204	46.6	1700	8.38	282	260	52.0	1720

Note 1: For ALTX NEO 0.1kW, the motor frame size changes for the following types.

[kW]	Motor Frame Size	Reduction Ratio Range			
		Indoor Type		Outdoor Type • Light Dust-proof Type	
		Without Brake/With Brake	Without Brake	With Brake	
0.1	F-56L	1/6 - 1/51		1/6 - 1/51	-
0.1	F-63S	1/3, 1/5, 1/59 - 1/1003		1/3, 1/5, 1/59 - 1/1003	1/3 - 1/1003

\*Consult us for confirmed values. Values above are subject to change without notice.

#### 2) 400V Class

Poles		4P														
Power		400V-50Hz					400V-60Hz					440V-60Hz				
Output [kW]	Motor Frame Size	Rated Current [A]	Max. Torque [%]	Starting Torque [%]	Starting Current [A]	Speed [r/min]	Rated Current [A]	Max. Torque [%]	Starting Torque [%]	Starting Current [A]	Speed [r/min]	Rated Current [A]	Max. Torque [%]	Starting Torque [%]	Starting Current [A]	Speed [r/min]
0.09	F-56L	0.33	253	232	1.0	1370	0.28	220	232	0.9	1640	0.29	276	247	1.0	1670
0.1	F-56L <sup>Note 2</sup>	0.35	225	206	1.0	1340	0.30	196	206	0.9	1610	0.30	246	220	1.0	1650
0.1	F-63S <sup>Note 2</sup>	0.36	255	261	1.3	1420	0.31	219	224	1.2	1700	0.32	277	289	1.4	1720
0.2	F-63M	0.62	233	236	2.3	1410	0.55	202	202	2.1	1700	0.55	257	266	2.4	1720
0.25	F-63M	0.70	205	225	2.6	1380	0.64	177	189	2.3	1660	0.62	228	251	2.6	1690
0.4	F-71M	1.23	229	229	4.5	1420	1.04	197	201	4.1	1700	1.04	249	262	4.6	1740
0.55	F-80S	1.41	219	227	5.6	1410	1.29	190	189	5.3	1680	1.24	237	240	5.9	1710
0.75	F-80M	1.94	234	215	8.0	1420	1.72	211	190	7.6	1720	1.68	253	242	8.4	1740
1.1	F-90S	2.67	246	225	13.3	1420	2.43	210	194	12.2	1690	2.33	263	246	13.6	1720
1.5	F-90L	3.49	233	224	17.1	1430	3.15	205	192	15.6	1710	3.00	250	243	17.5	1730
2.2	F-100L	4.87	268	255	26.0	1430	4.45	229	204	23.3	1700	4.19	282	260	26.0	1720

Note 2: For ALTX NEO 0.1kW, the motor frame size changes for the following types.

[kW]	Motor Frame Size	Reduction Ratio Range			
		Indoor Type		Outdoor Type • Light Dust-proof Type	
		Without Brake/With Brake	Without Brake	With Brake	
0.1	F-56L	1/6 - 1/51		1/6 - 1/51	-
0.1	F-63S	1/3, 1/5, 1/59 - 1/1003		1/3, 1/5, 1/59 - 1/1003	1/3 - 1/1003

\*Consult us for confirmed values. Values above are subject to change without notice.



### 2. Single-Phase Motor (Without Brake/With Brake, Indoor)

#### 1) 100V Class

Poles		4P									
Power		100V-50Hz					100V-60Hz				
Output [kW]	Motor Frame Size	Rated Current [A]	Max. Torque [%]	Starting Torque [%]	Starting Current [A]	Speed [r/min]	Rated Current [A]	Max. Torque [%]	Starting Torque [%]	Starting Current [A]	Speed [r/min]
0.09	FS-56L	1.6	154	72	3.5	1350	1.6	168	88	3.2	1650
0.1	FS-63M	2.8	240	223	10.4	1450	2.2	233	242	10.0	1740
0.2	FS-71M	4.1	217	224	17.5	1440	3.3	213	196	16.8	1730
0.4	FS-80M	6.8	210	224	31.8	1440	5.8	210	232	32.5	1740

#### 2) 200V Class

Poles		4P									
Power		200V-50Hz					200V-60Hz				
Output [kW]	Motor Frame Size	Rated Current [A]	Max. Torque [%]	Starting Torque [%]	Starting Current [A]	Speed [r/min]	Rated Current [A]	Max. Torque [%]	Starting Torque [%]	Starting Current [A]	Speed [r/min]
0.09	FS-56L	0.78	152	75	1.7	1340	0.79	172	99	1.5	1640
0.1	FS-63M	1.4	236	208	5.4	1450	1.1	231	194	5.0	1740
0.2	FS-71M	2.1	217	200	8.7	1440	1.7	210	180	8.2	1730
0.4	FS-80M	3.4	221	210	16.2	1440	2.9	213	206	16.4	1740

### 3. Gearmotor for Inverter (Without Brake/With Brake, Indoor)

#### 1) 200V, 400V Class

Poles		4P															
Voltage		200 Class								400 Class							
Power		200V-60Hz				220V-60Hz				400V-60Hz				440V-60Hz			
Output [kW]	Motor Frame Size	Frequency [Hz]	Voltage [V]	Rated Current [A]	Speed [r/min]	Frequency [Hz]	Voltage [V]	Rated Current [A]	Speed [r/min]	Frequency [Hz]	Voltage [V]	Rated Current [A]	Speed [r/min]	Frequency [Hz]	Voltage [V]	Rated Current [A]	Speed [r/min]
0.1	FA-63S	60	200	0.83	1750	60	220	0.91	1760	60	400	0.42	1750	60	440	0.46	1760
		6	34	0.75	120	6	34	0.75	120	6	68	0.37	125	6	68	0.38	125
0.2	FA-63M	60	200	1.5	1750	60	220	1.6	1760	60	400	0.74	1755	60	440	0.84	1765
		6	34	1.5	130	6	34	1.5	130	6	68	0.75	130	6	68	0.75	130
0.4	FA-71M	60	200	2.3	1735	60	220	2.4	1745	60	400	1.2	1735	60	440	1.2	1745
		6	35	2.2	115	6	35	2.2	115	6	70	1.1	115	6	70	1.1	115
0.75	FA-80M	60	200	3.9	1740	60	220	4.0	1755	60	400	1.9	1740	60	440	2.0	1755
		6	31	3.9	120	6	31	3.9	120	6	62	1.9	120	6	62	1.9	120
1.5	FA-90L	60	200	6.6	1720	60	220	6.4	1735	60	400	3.3	1720	60	440	3.2	1735
		6	33	6.5	105	6	33	6.5	105	6	66	3.2	105	6	66	3.2	105
2.2	FA-100L	60	200	9.3	1745	60	220	9.1	1755	60	400	4.7	1745	60	440	4.5	1755
		6	31	9.4	140	6	31	9.3	140	6	62	4.7	140	6	62	4.7	140

\*Consult us for confirmed values. Values above are subject to change without notice.

# Technical Data

## Characteristics of Brakes

### 1. Three-Phase Motor, Characteristics of the Electromagnetic Brake

Brake Type	Motor Capacity	Standard Torque [N·m]	Moment of Inertia [ $\times 10^{-4}$ kgm <sup>2</sup> ]	Total Braking Energy [ $\times 10^7$ J]	Motion Delay Time [s]		Brake Current [A]				
					Standard Braking Action	Fast Braking Action	200V 50/60Hz	220V 60Hz	380V 50Hz	400V 50/60Hz	440V 60Hz
RB-01A	90W	0.8	1.5	1.0	0.08 - 0.1	0.03 - 0.04	0.05	0.05	-	0.02	0.03
	0.1kW										
FB-01A1	90W	1.0	3.5	12	0.15 - 0.2	0.015 - 0.02	0.07	0.08	0.03	0.04	0.04
	0.1kW										
FB-02A1	0.2kW	2.0	5.5	12	0.15 - 0.2	0.015 - 0.02	0.1	0.1	0.05	0.05	0.06
	0.25kW										
FB-05A1	0.25kW	4.0	6.8	12	0.1 - 0.15	0.01 - 0.015	0.1	0.1	0.05	0.05	0.06
	0.4kW										
FB-1B	0.55kW	7.5	13	33	0.2 - 0.3	0.01 - 0.02	0.1	0.1	0.1	0.1	0.1
	0.75kW										
FB-2B	1.1kW	15	24	38	0.2 - 0.3	0.01 - 0.02	0.3	0.3	0.1	0.1	0.2
	1.5kW										
FB-3B	2.2kW	22	38	45	0.3 - 0.4	0.01 - 0.02	0.3	0.3	0.1	0.1	0.2

### 2. Single-Phase Motor, Characteristics of the Electromagnetic Brake

Brake Type	Motor Capacity	Standard Torque [N·m]	Moment of Inertia [ $\times 10^{-4}$ kgm <sup>2</sup> ]	Total Braking Energy [ $\times 10^7$ J]	Motion Delay Time [s]		Brake Current [A]	
					Standard Braking Action	Fast Braking Action	100V 50/60Hz	200V 60Hz
RB-01A	90W	0.8	1.5	1.0	0.08 - 0.1	0.03 - 0.04	0.08	0.05
FB-01A1	0.1kW	1.0	5.5	12	0.15 - 0.2	0.015 - 0.02	0.1	0.1
FB-02A1	0.2kW	2.0	6.8	12	0.15 - 0.2	0.015 - 0.02	0.1	0.1
FB-1B	0.4kW	4.0	13	33	0.3 - 0.4	0.01 - 0.02	0.2	0.2

### 3. Three-Phase Motor for Inverter, Characteristics of the Electromagnetic Brake

Brake Type	Motor Capacity	Standard Torque [N·m]	Moment of Inertia [ $\times 10^{-4}$ kgm <sup>2</sup> ]	Total Braking Energy [ $\times 10^7$ J]	Motion Delay Time [s]		Brake Current [A]			
					Standard Braking Action	Fast Braking Action	200V 50/60Hz	220V 60Hz	400V 50/60Hz	440V 60Hz
FB-02A1	0.1kW	2.0	5.5	12	0.08 - 0.12	0.015 - 0.02	0.1	0.1	0.05	0.06
FB-05A1	0.2kW	4.0	6.8	12	0.03 - 0.07	0.01 - 0.015	0.1	0.1	0.05	0.06
FB-1B	0.4kW	7.5	13	33	0.1 - 0.15	0.01 - 0.02	0.1	0.1	0.1	0.1
FB-2B	0.75kW	15	24	38	0.1 - 0.15	0.01 - 0.02	0.3	0.3	0.1	0.2
FB-3B	1.5kW	22	38	45	0.15 - 0.2	0.01 - 0.02	0.3	0.3	0.1	0.2
FB-5B	2.2kW	37	96	235	0.2 - 0.25	0.01 - 0.02	0.5	0.6	0.3	0.3

- The figure is continuous rating for brake.
- Avoid conducting power to the brake continuously while the motor at stop.
- Brake lining does not contain asbestos.
- The brakes have a mechanical service life of 2 million brakings under general usage conditions.
- The rectifier is built into the brake section for 90W or 0.1kW RB brakes, and in the terminal box for FB brakes of 0.1kW or above.
- Use a quick braking circuit for use in hoisting machines or for higher braking precision.
- FB brakes needs DC power supply, and the spring braking system (non-electromagnetic braking system) is adopted.
- The "standard torque" above represents dynamic friction torque.

## 4. Rectifier's Output Voltage for Brakes with Three-Phase Motor and Three-Phase Motor for Inverter

Rectifier's output voltage for Three-phase brake

Input Voltage	Output Voltage
AC200V	DC90V
AC220V	DC99V
AC400V	DC180V
AC440V	DC198V

### Why Quick Braking Circuit Shortens Braking Time

Refer to the Standard Circuit and Quick Braking Circuit for differences between standard braking circuit and fast braking circuit.

Refer to the Current Curve of Standard Braking and Current Curve of Quick Braking for current curves of standard braking and fast braking.

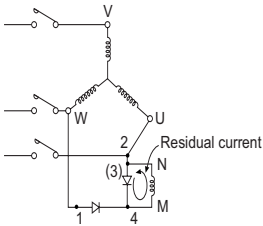

Fig. 1 Standard Circuit

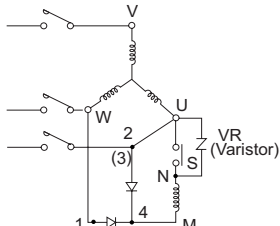

Fig. 2 Quick Braking Circuit

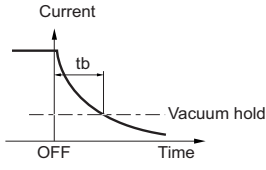

Fig. 3 Current Curve of Standard Braking Circuit

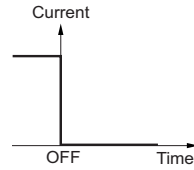
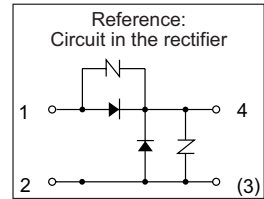

Fig. 4 Current Curve of Quick Braking Circuit



In the standard circuit shown in Fig. 1 Standard Circuit, some current remains after the power is turned off. This is due to the energy charged in the inductance  $L$  of the brake coil. The current curve is shown in Fig. 3 Current Curve of Standard Braking.

When it is connected to the fast braking circuit as shown in Fig. 2 Quick Braking Circuit and  $S$  is released at the same time, no current remains as there is no closed circuit with the brake coil. (Refer to Fig. 4)

Therefore, it shortens the braking time by  $t_b$  as shown in Fig. 3.

Fast braking circuit is to release all current by ON/OFF of brake coil at the same time with power ON/OFF. (Always use VR varistor to protect the rectifier and connection  $S$ .)

# Technical Data

## Connection

### 1. Connection for a Three-Phase Motor (without Brake)

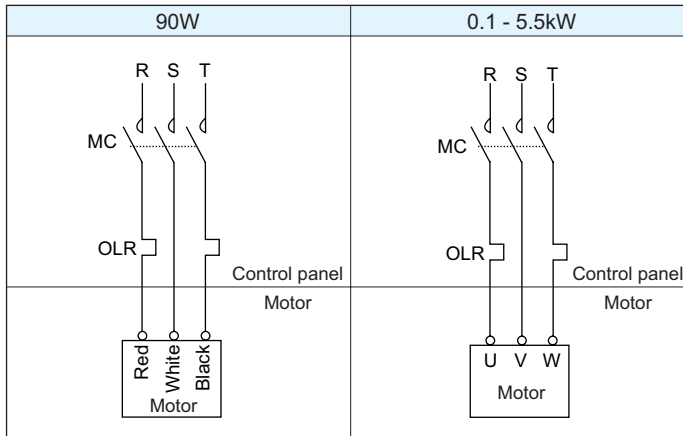

### 2. Connection for a Three-Phase Motor for Inverter (without Brake)

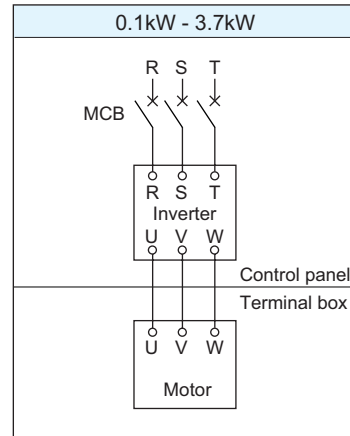

Note: MC: Electromagnetic contactor  
OLR: Overload relay or thermal relay } are not supplied by Sumitomo.

Note: MCB (wiring breaker) is not supplied by Sumitomo.

### 3. Connection for a Single-Phase Motor (without Brake)

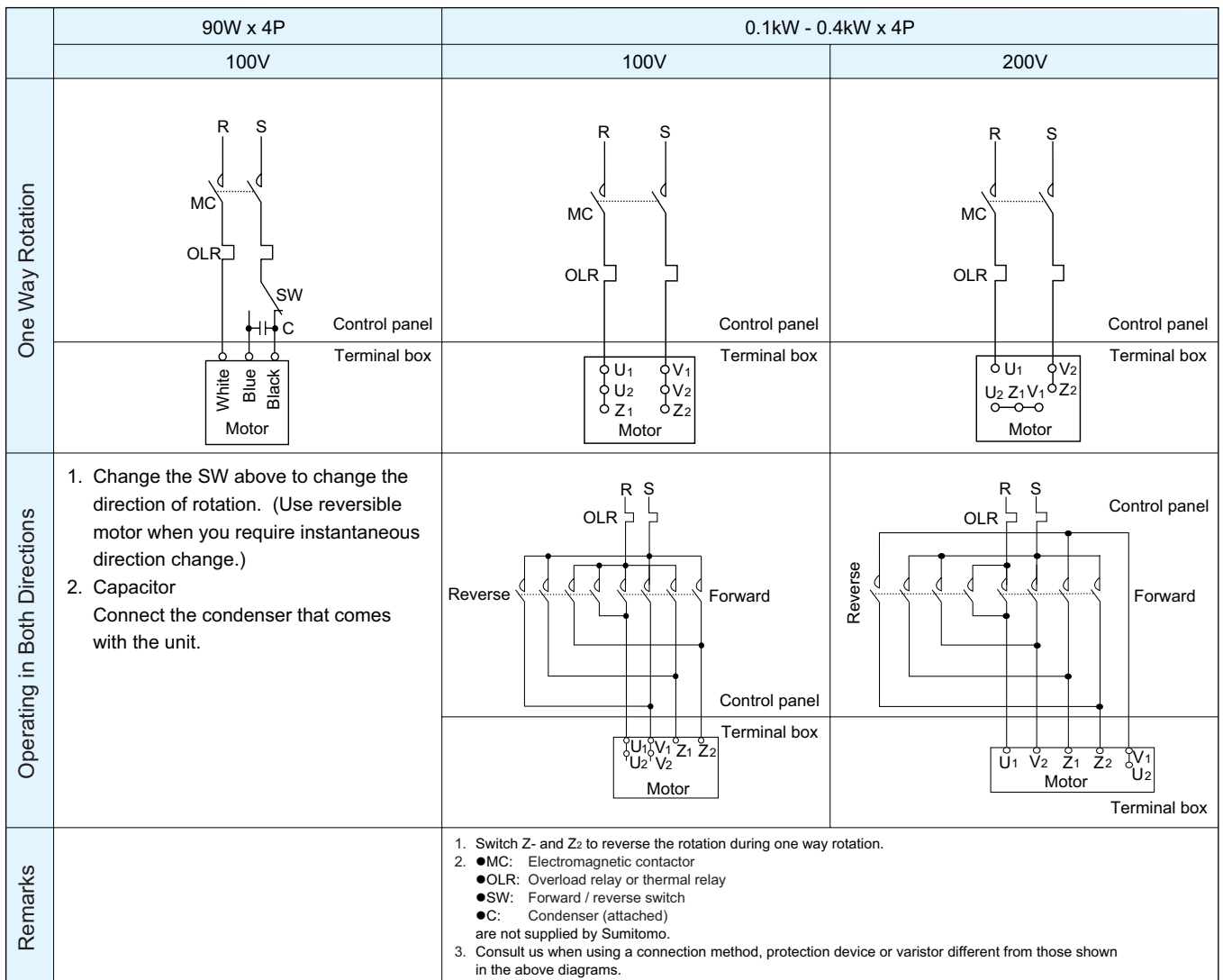

\*Refer to the relevant instruction manual for wiring for gearmotors with brake.

# Technical Data

## Standard Paint Properties and Color

### 1. Standard Paint Properties

ALTAX NEO

Model	Treatment	Paint Type		Additional Leadtime [Days]	Paint Specifications			Applied Paint		Weather Resistance	Submersible	Oil-proof	Acid Resistance	Alkaline Resistance	Heat Resistance [°C]	Application
		Classification	Paint Type (Top-coat)		Type	Layers (Thickness [μ])	Quality	Brand								
90W - 2.2kW Indoor / outdoor three-phase / single-phase motor Motor for inverter	Cast Iron: Near Whiteblast cleaning	Standard	-	0	Under coat	1 (20 - 40)	Modified alkyd resin	Unigrand PTC Primer							100	Standard under coat
	Steel plate: Power tool cleaning		Acrylic urethane	0	Finish coat	1 (15 - 30)	Acrylic urethane resin	Liac 4000 PTC	◎	△	△	◇	◇	100	Standard finish coat	

◎○◇: Appropriate  
 △: Caution  
 necessary for  
 selection  
 ×: Inappropriate

### 2. Standard Paint Color

ALTAX NEO

Model	Paint Color
90W - 2.2kW Indoor / outdoor Three-phase / single-phase motor Motor for inverter	Munsell 5Y 8/1 or equivalent (approximate)





# Warranty Standards and Safety Precautions

## Warranty Standard

Warranty Period	The warranty period for the Products shall be 18 months after the commencement of delivery or 18 months after the shipment of the Products from the seller's works or 12 months from the Products coming into operation, whichever comes first.
Warranty Condition	<p>In the event that any problem or damage to the Product arises during the "Warranty Period" from defects in the Product whenever the Product is properly installed and combined with the Buyer's equipment or machines, maintained as specified in the maintenance manual, and properly operated under the conditions described in the catalog or as otherwise agreed upon in writing between the Seller and the Buyer or its customers; the Seller will provide, at its sole discretion, appropriate repair or replacement of the Product without charge at a designated facility, except as stipulated in the "Warranty Exclusions" as described below.</p> <p>However, if the Product is installed or integrated into the Buyer's equipment or machines, the Seller shall not reimburse the cost of: removal or re-installation of the Product or other incidental costs related thereto, any lost opportunity, any profit loss or other incidental or consequential losses or damages incurred by the Buyer or its customers.</p>
Warranty Exclusions	<p>Notwithstanding the above warranty, the warranty as set forth herein shall not apply to any problem or damage to the Product that is caused by:</p> <ol style="list-style-type: none"> <li>1. Installation, connection, combination or integration of the Product in or to the other equipment or machine that is rendered by any person or entity other than the Seller;</li> <li>2. Insufficient maintenance or improper operation by the Buyer or its customers, such that the Product is not maintained in accordance with the maintenance manual provided or designated by the Seller;</li> <li>3. Improper use or operation of the Product by the Buyer or its customers that is not informed to the Seller, including, without limitation, the Buyer's or its customers, operation of the Product not in conformity with the specifications, or use of lubricating oil in the Product that is not recommended by the Seller;</li> <li>4. Any problem or damage on any equipment or machine to which the Product is installed, connected or combined or on any specifications particular to the Buyer or its customers;</li> <li>5. Any changes, modifications, improvements or alterations to the Product or those functions that are rendered on the Product by any person or entity other than the Seller;</li> <li>6. Any parts in the Product that are supplied or designated by the Buyer or its customers;</li> <li>7. Earthquake, fire, flood, sea-breeze, gas, thunder, acts of God or any other reasons beyond the control of the Seller;</li> <li>8. Normal wear and tear, or deterioration of the Product's parts, such as bearings, oil-seals;</li> <li>9. Any other troubles, problems or damage to the Product that are not attributable to the Seller.</li> </ol>

## For Users of the Gearmotor:

### SAFETY PRECAUTIONS

- Observe safety rules for installation site and equipment strictly (Industrial Safety and Health Law, Technical Standard for Electric Facilities, Extension Rules, Plant Explosion guidelines, Building Standards Law, etc.)
- Read the maintenance manual carefully before use. Request one from the distributor you purchased from or our sales department if it is not handy. The maintenance manual must reach the actual user.
- Select an appropriate product to match the operating environment and application.
- Install protective equipment on the machine side when the machine is used for passenger transportation and elevators, escalators, and dumb waiters.
- Use a flameproof type motor for use in explosive environment. Select a flameproof type motor with appropriate specifications sufficient for hazardous locations.
- When the 400V class standard motor is driven with the inverter, the high carrier frequency shape (ex. IGBT: Insulated Gate Bipolar Transistor) inverter with higher input voltage (400V or more) or insulation pressure for the motor in the case of long distance wiring, should be considered. In such case, consult us. (The motor for inverter is designed to be of insulation reinforced type).
- Install an oil pan or other devices to prevent oil or grease leakage, just in case of failure or termination of service life, for oil-sensitive applications such as food processing and clean rooms.