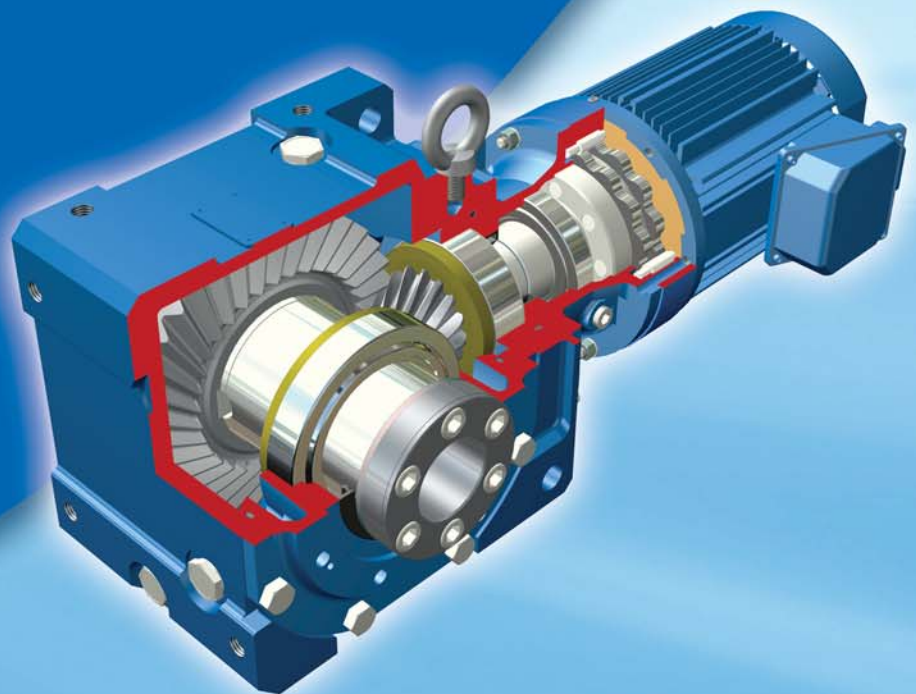


Sumitomo Drive Technologies  
*Always on the Move*

# Cyclo<sup>®</sup> BBB

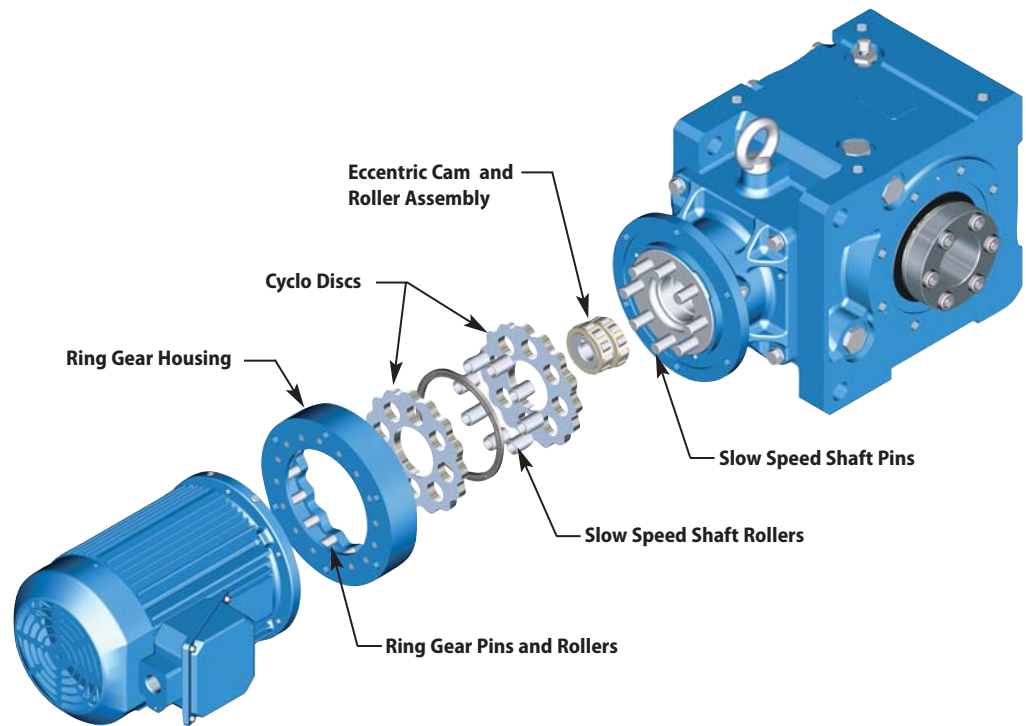
BEVEL BUDDYBOX

Speed Reducers and Gearmotors  
featuring Keyless Taper-Grip<sup>®</sup> Bushing



CATALOG 13.601.50.006

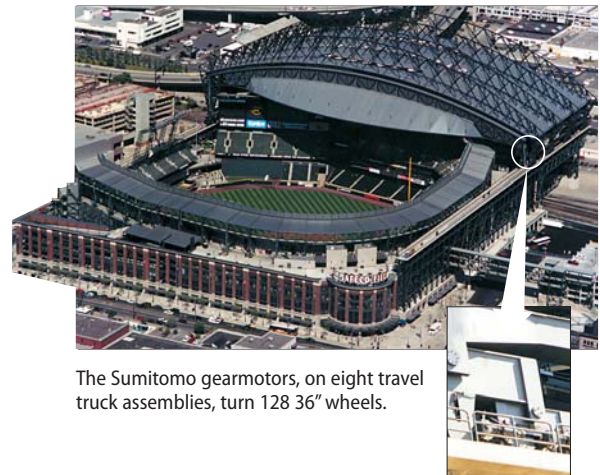
- ▶ Rugged Spiral Bevel Output
- ▶ Modular Cyclo<sup>®</sup> Input
- ▶ Compact Size
- ▶ Two-Year Warranty



## Right Angle Drives Designed for Demanding Applications

In less than 20 minutes, 96 Sumitomo Cyclo<sup>®</sup> Bevel Buddybox gearmotors help retract the 13,000-ton roof on Seattle's Safeco Field.

To request a catalog, or for more information on any of our high quality products, please visit our Website:



The Sumitomo gearmotors, on eight travel truck assemblies, turn 128 36" wheels.

# Speed Reducers and Gearmotors

## Table of Contents

### 1. General Information

### 2. Speed Reducers

How to Select .....	2.2
Configure a Model Number (Nomenclature) ...	2.4
AGMA Load Classifications .....	2.6
Selection Tables .....	2.8
Single Reduction .....	2.8
Horizontal Mounting .....	2.8
Vertical Mounting .....	2.12
Double Reduction .....	2.16
Dimensions .....	2.22

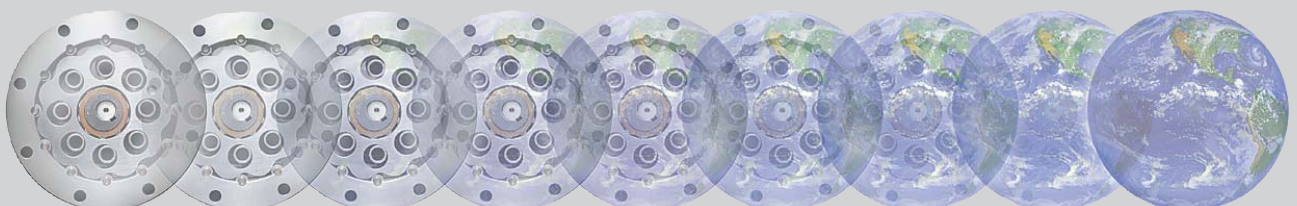
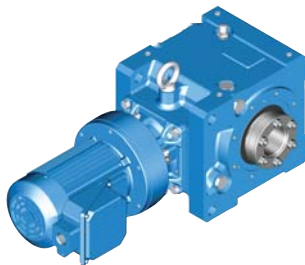
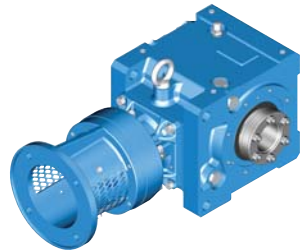
### 3. Gearmotors

How to Select .....	3.2
Configure a Model Number (Nomenclature) ...	3.4
AGMA Load Classifications .....	3.6
Selection Tables .....	3.8
Horizontal Mounting .....	3.8
Vertical Mounting .....	3.28
Dimensions .....	3.38

### 4. Options

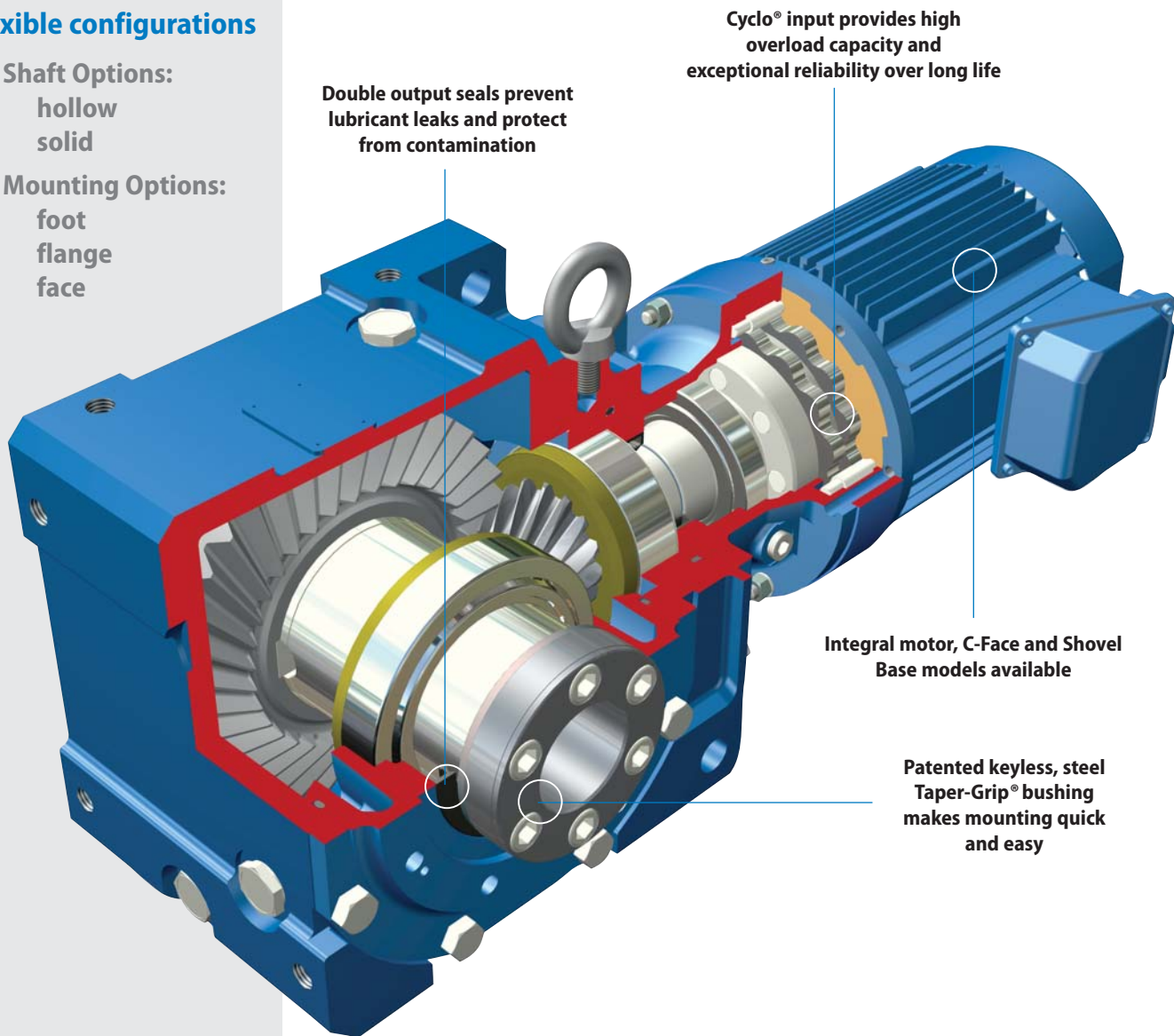
### 5. Appendices

Special Load Guidelines .....	5.2
Taper-Grip® Bushing .....	5.6
Installation .....	5.9
Parts List .....	5.10
Motor Data .....	5.14
Standard Wiring .....	5.19
Brakemotor Characteristics .....	5.21
Lubrication .....	5.26
Additional Mounting Configurations .....	5.28
Warranty .....	5.33



## ► Flexible configurations

- Shaft Options:  
hollow  
solid
- Mounting Options:  
foot  
flange  
face



## Cyclo<sup>®</sup> Quality and Reliability, Right Angle Design

- High performance steel gearing components deliver **up to 94% efficiency**





## Product Description

Sumitomo's Cyclo® Bevel Buddybox (Cyclo® BBB) speed reducers and gearmotors are the **ultimate right angle drives for challenging applications**. The Cyclo® BBB combines the quiet, efficient and reliable performance of the Cyclo® technology input with the **rugged spiral bevel** gearbox output. The **modular design** provides a compact, torque-dense product with the most flexible range of output speed and torque combinations available. The Cyclo® BBB easily adapts to shaft-mounted as well as solid shaft mounting arrangements. Sumitomo's patented Taper Grip® bushing system enhances the Cyclo® BBB value by offering a simple shaft-mounting device that **provides self-aligning, backlash-free torque transmission** to the driven shaft. The Cyclo® BBB and Taper Grip® bushing system provide solutions for the most demanding applications.

## Features & Benefits

- **Cycloidal speed reduction technology**
  - ~ Quiet, efficient and reliable operation with high torque density and compact size
- **Modular design**
  - ~ Interchangeable cast iron housings in foot, flanged or face mount configurations
- **High performance steel spiral bevel gearing**
  - ~ Deliver efficiencies of up to 94% across the entire product range
- **Double output seals**
  - ~ Virtually leak-free operation and optimal protection from lubrication contamination
- **Taper Grip® Bushing**
  - ~ Simple, steel, keyless shaft mounting system resists fretting and eases unit installation and removal from driven shaft

## Specifications Summary

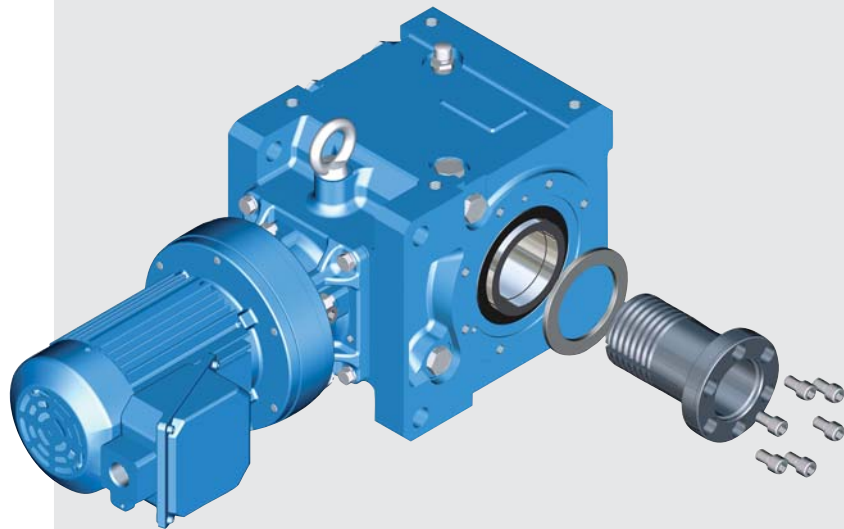
<b>Ratios:</b>	11:1 to 26,000:1 and greater
<b>Torque Capacity:</b>	94,700 in. lbs.
<b>HP:</b>	1/8 to 40
<b>Mounting:</b>	Hollow Shaft, Solid Shaft with Foot, Flange, Face
<b>Options:</b>	Integral Motor, C-Face and Shovel Base
<b>Motor Standards:</b>	NEMA, IEC, JIS, UL, CSA, CE

### ► **Keyless, steel Taper-Grip® bushing makes mounting of hollow shaft units easy and economical**

The Sumitomo **Taper-Grip®** bushing is a keyless, torque transmission device integrated into the shaft mounted, right angle Cyclo® BBB reducer and gearmotor product lines.

The **unique, patented design** has a number of benefits:

- Easy mounting and removal of the unit to and from the driven shaft
- Standard bore sizes require no shaft preparation such as a keyway, undercut, or keeper plate
- Backlash free torque transmission
- Works with standard shafting, no special tolerances required
- Automatic shaft center alignment
- Resistant to fretting and corrosion
- Multiple stock bore sizes for quick delivery.



### ► **Applications**

- Material Handling
- Asphalt Mixers
- Capstan Drive
- Rolling Mill Table
- Wire Drawing Machines
- Food Processing
- Belt Filter Presses
- Shredders/Compactors

# Product Range (Standard Motor and Reducer Combinations)

## Single Reduction Ratios 11 – 417 Combinations with 1750 RPM motor

Ratio	11	18	21	28	39	46	53	60	74	88	102	123	151	179	207	249	305	417
Output Speed RPM (60 Hz)	159	97.2	83.3	62.5	44.9	38	33	29.2	23.6	19.9	17.2	14.2	11.6	9.8	8.45	7.03	5.74	4.20

1/4																			
1/3																			
1/2																			
3/4																			
1																			
1.5																			
2																			
3																			
5																			
7.5																			
10																			
15																			
20																			
25																			
30																			
40																			

## Double Reduction Ratios 364 – 10658 Combinations with 1750 RPM motor

Ratio	364	424	501	578	683	809	956	1117	1320	1656	1957	2272	2559	2944	3511	4365	5177	7228	10658
Output Speed RPM (60 Hz)	4.81	4.13	3.5	3.03	2.56	2.16	1.83	1.57	1.33	1.06	0.894	0.77	0.684	0.595	0.499	0.401	0.338	0.242	0.164

1/8																			
1/4																			
1/3																			
1/2																			
3/4																			
1																			
1.5																			
2																			
3																			
5																			
7.5																			

**How do I select a Cyclo® BBB speed reducer or gearmotor?**

Selection is based on the actual horsepower and/or torque requirements at the output shaft. The Cyclo® BBB speed reducer has particularly high efficiencies over a wide range of reduction ratios, which frequently permits the use of reduced input power requirements (smaller HP motor) without sacrificing output shaft torque. The selection procedures in this catalog will guide you in choosing the most efficient reducer for your application.

**What information do I need to get started in the selection process?**

To select the proper reducer for your application, you will need to know:

- Application: type of driven machine
- Hours of operation per day
- Motor horsepower (HP) and speed (RPM)
- Mounting position

If there are any special environmental factors or operation requirements, they must also be noted. This information will be important in determining the Service Factor of your application.

**What are Service Factors and how are they used?**

In general, reducers and gearmotors are rated for the specific conditions and operating requirements of the application by the use of AGMA-defined Service Factors. There are three AGMA load classifications for reducers: uniform (U), moderate shock (M) and heavy shock (H) (page 2.6) and three AGMA load classifications for gearmotors: I, II and III (pages 3.6–3.7). The Service Factors are used in the product selection process to adjust for the specific conditions and operating requirements of your application.

**What do I do if my application has particularly severe operating conditions?**

The standard ratings for Cyclo® BBB are based on 10-hour daily service under conditions of uniform loads (equivalent to AGMA service factor 1.0). By following the product selection process, you will determine and apply the Service Factors to compensate for the severe operating conditions.

**How can I be sure that the reducer can withstand periodic excessive overloads?**

Cyclo® BBB Speed Reducers provide 300% momentary intermittent shock load capacity. For applications with shock loads greater than 300%, consult a Sumitomo Application Engineer.

**What are the standard input speeds?**

In general terms, the speeds are 1750 and 1165 RPM. The selection tables in this catalog are based on 1750 RPM. When non-standard input speeds are used, the horsepower and torque ratings also vary.

**What thermal capacity limitations does the Cyclo® BBB have?**

The Cyclo® speed reducer, by virtue of its smooth, almost frictionless operation (unlike traditional helical gears), has a thermal rating that far exceeds its mechanical capacity and all but eliminates the conventional limitations due to heat.

**What are the advantages of the Taper-Grip® bushing?**

The Taper-Grip® bushing is integral to the Cyclo® BBB and provides for easy mounting and removal to and from the shaft of the driven machine. Because it requires no keyway, the shaft isn't weakened and maximum torque is transmitted.

**What are the advantages of the new Steel Taper-Grip® bushing?**

With an increased torque capacity, the new Steel Taper-Grip® bushing can be used in reversing and/or high start-up applications. The new Steel Taper-Grip® bushing can be used on all Taper-Grip® products.

**What kind of torque arm do I specify? At what position should I mount it?**

The standard torque arm assembly supplied is a turnbuckle type as shown on page 4.4. The torque arm should be mounted at 90 degrees to a line from the point of attachment to the reducer and the center of the output bore with up to 30 degrees plus or minus variance. A bracket type torque arm is also offered as a non-stock option.

# Standard Specifications

---

	Standard Specifications	Standard Specifications with Built-In Brake	
<b>3-Phase Integral Motor</b>	<b>Capacity Range:</b>	1/8 HP ~ 40 HP, 4P	1/8 HP ~ 15 HP, 4P: FB Brake 20 HP, 4P: CMB Brake 25 HP ~ 40 HP, 4P: ESB Brake
	<b>Enclosure:</b>	Totally enclosed fan cooled type (1/8 HP, 4P Totally enclosed non ventilated)	Totally enclosed fan cooled type (1/8 HP, 4P Totally enclosed non ventilated)
	<b>Power Supply:</b>	230/460 Volts, 60 Hz 575 Volts, 60 Hz	230/460 Volts, 60 Hz 575 Volts, 60 Hz
	<b>Insulation:</b>	3/4 ~ 30 HP: Class B 40 HP: Class F	3/4 ~ 20 HP: Class B
	<b>Time Rating</b>	Continuous	Continuous

---

<b>Reducer</b>	<b>Reduction:</b>	Combination of Cyclo input and right angle spiral bevel gear output.
	<b>Lubrication:</b>	Cyclo portion is grease or oil lubricated; Bevel portion is oil lubricated.
	<b>Seals:</b>	Nitrile material, dual lipped, double output seals.
	<b>Material:</b>	Rugged cast iron housings
	<b>Paint Color:</b>	Blue, Munsell color number 6.5PB 3.6/8.2
	<b>Bearings:</b>	Tapered roller bearings on geared output; ball bearings on Cyclo input.

---

<b>Ambient Conditions</b>	<b>Installation Location:</b>	Indoors (Minimal dust and humidity)
	<b>Ambient Temperature:</b>	14°~104° F (-10° ~ 40° C)
	<b>Ambient Humidity:</b>	Under 85%
	<b>Elevation:</b>	Under 3,281 ft. (1000 meters)
	<b>Atmosphere:</b>	Well ventilated location, free of corrosive gases, explosive gases, vapors and dust.

## Shaft Rotation

On single reduction Cyclo BBB speed reducers, ratios 11 through 417, the slow speed shaft rotates in a reverse direction to that of the high speed shaft.

On double reduction units, ratios 357 through 26,492, both the high speed and the slow speed shaft rotate in the same direction.

## Input Speeds

In general terms, the standard input speeds of single reduction units are 1750 and 1165 RPM. When non-standard input speeds are used, the horsepower and torque ratings will also vary.

## Thermal Capacity

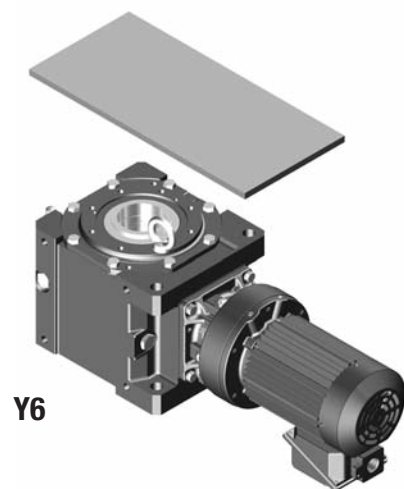
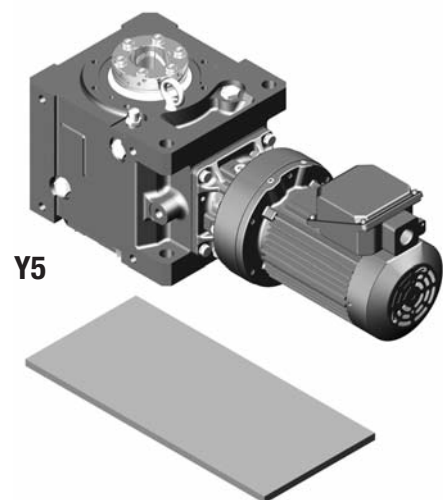
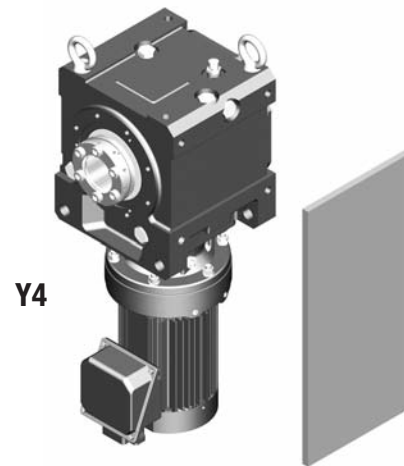
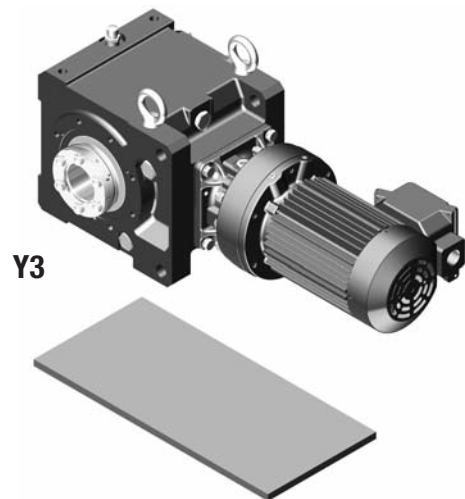
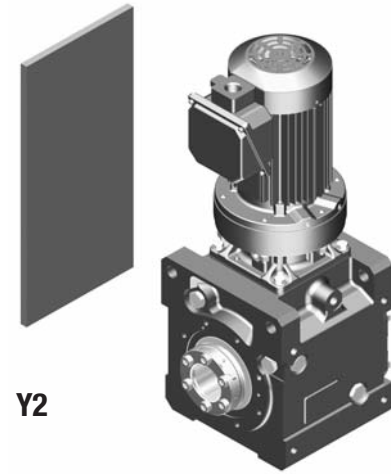
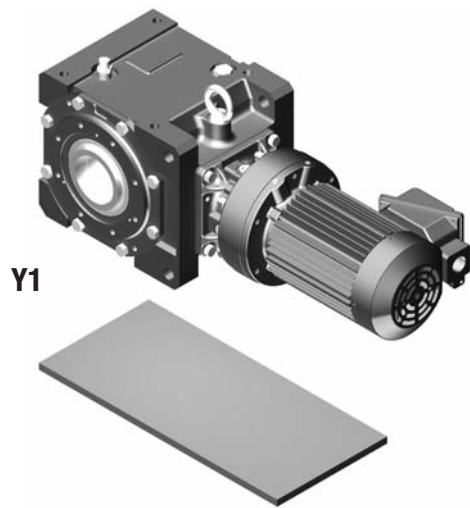
The Cyclo BBB speed reducer's smooth, almost frictionless operation all but eliminates the conventional limitations due to heat. In all sizes, Cyclo BBB speed reducers have thermal ratings that exceed their mechanical capacity.



# Mounting Positions

Please see the appendix for additional mounting configurations.

Note: Y1 position eyebolt provided as standard for all positions. Consult factory for eyebolts shown for positions Y2-Y6.

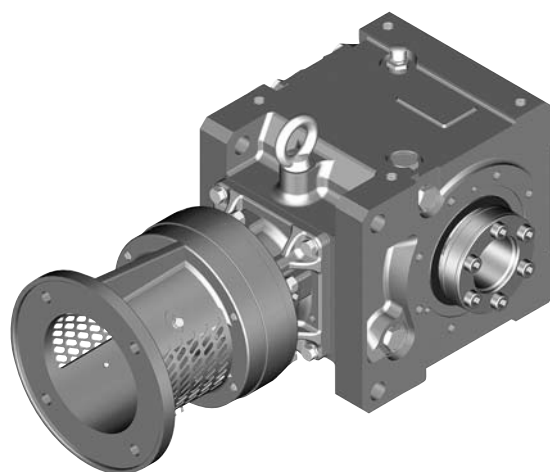


This page intentionally left blank.

# 2

# Speed Reducers

---



Speed  
Reducers

How to  
Select

# How to select a Speed Reducer

## Step 1: Collect data about your application

Before starting you need to know the:

- **Application (e.g. Conveyor, Mixer, etc.)**
- **Hours of Operation per day**
- **Motor Horsepower (HP) and Speed (RPM)**
- **Desired Output Speed**
- **Mounting Position and Style**
- **Overhung or Thrust Loads**
- **Bore Dimensions, inch or metric**

## Step 2: Choose a Mounting Position

Find the correct Mounting Position from the *Mounting Positions Table* on the right.

## Step 3: Select a Frame Size

**3A:** Find the **Load Classification** of your application in the *AGMA Load Classification Table* on page 2.6.

**3B:** Find the recommended **Service Factor** using the *Recommended Reducer Service Factor Table* on the right.

**3C:** Determine the **Selection Horsepower** by multiplying the Motor Horsepower by the Service Factor.

**3D:** Select a **Frame size** from the Reducer Selection Tables on pages 2.8–2.21 by matching both the Selection Horsepower and Desired Output Speed (RPMs) to a frame size model number. Note: For Mounting Positions Y1, Y3, Y5, Y6 see pages 2.8–2.11. For Mounting Positions Y2 and Y4 see pages 2.12–2.15.) For all Double Reduction Mounting Positions see pages 2.16–2.21.

## Step 4: Verify Dimensions

Use the Dimensions information on pages 2.22–2.25 to verify that the selected Frame Size is appropriate.

## Step 5: Choose a Bushing Bore Size

Choose a Taper Grip Bushing Bore Size from the *Stock Bushing Bore Size Table*.

## Step 6: Choose Options

The following options may apply:

### Washdown Modification

### Breather

Please see the *Cyclo BBB pricelist*, or visit our website at [www.smcyclo.com](http://www.smcyclo.com) for available modifications.

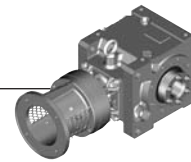
## Step 7: Configure a Model Number

Go to page 2.4 to configure a model number.

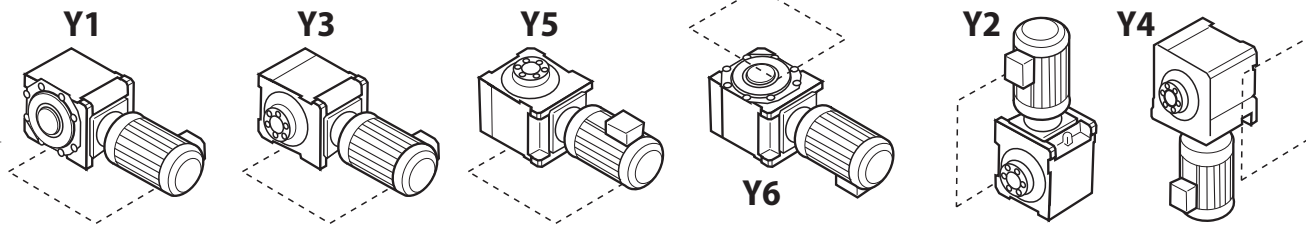
**Note:** You will use the information you gather from the procedure on this page to Configure a Model Number.

STOCK BUSHING BORES

Size	Inch Sizes	Metric Sizes	Min. Bore
A	1 <sup>1</sup> / <sub>16</sub> , 2 <sup>3</sup> / <sub>16</sub>	50, 55	1 <sup>1</sup> / <sub>16</sub>
B	2 <sup>3</sup> / <sub>16</sub> , 2 <sup>7</sup> / <sub>16</sub>	60, 65	1 <sup>1</sup> / <sub>16</sub>
C	2 <sup>7</sup> / <sub>16</sub> , 2 <sup>11</sup> / <sub>16</sub>	65, 75	2 <sup>3</sup> / <sub>16</sub>
D	2 <sup>11</sup> / <sub>16</sub> , 3 <sup>1</sup> / <sub>16</sub>	75, 85	2 <sup>7</sup> / <sub>16</sub>
E	3 <sup>1</sup> / <sub>16</sub> , 3 <sup>5</sup> / <sub>16</sub>	90, 100	2 <sup>11</sup> / <sub>16</sub>



Mounting Positions



Recommended Reducer Service Factors		AGMA Load Classifications		
		Uniform (U)	Moderate Shock (M)	Heavy Shock (H)
Duration of Service	1/2 hr. per day (Occasional)	0.50*	0.80*	1.25
	3 hrs. per day (Intermittent)	0.80*	1.00	1.50
	Up to 10 hrs. per day	1.00	1.25	1.75
	24 hrs. per day	1.20	1.50	2.00

\*Maximum momentary or starting load must not exceed 300% of gear reducer rating (rating meaning service factor of 1.0). Time specified for occasional and intermittent service refers to total operating time per day.

Speed Reducers

How to Select

**Determine Selection Horsepower (HP)**

$$\text{Motor HP} \times \text{Service Factor} = \text{Selection HP}$$

**Example:** 10 Motor HP X 1.25 Service Factor = 12.5 Selection HP

**Select a Frame Size**

**1 Match your OUTPUT RPM (or RATIO)...**

Output RPM	19.9	17.2	14.2	11.6	9.8	8.45	7.03	5.74	Frame Size
Ratio	88	102	123	151	179	207	249	305	
<b>Input HP</b>	<b>1.70</b>	<b>1.62</b>	<b>1.42</b>	<b>1.05</b>	<b>0.75</b>	<b>0.69</b>	<b>0.58</b>	<b>0.58</b>	<b>3A100</b>
Output Torque (in•lbs)	4953	5461	5248	4447	4735	4791	5859		
Hollow Shaft OHL (lbs)	1120	1120	1120	1120	1120	1120	1120		
Solid Shaft OHL (lbs)	990	990	990	990	990	990	990		
<b>Input HP</b>	<b>2.24</b>	<b>2.13</b>	<b>2.01</b>	<b>1.75</b>	<b>1.55</b>	<b>1.45</b>	<b>1.20</b>	<b>0.76</b>	<b>3A105</b>
Output Torque (in•lbs)	6527	7180	6881	5847	6200	6200	7677		
Hollow Shaft OHL (lbs)	1120	1120	1120	1120	1120	1120	1120		
Solid Shaft OHL (lbs)	990	990	990	990	990	990	990		
<b>Input HP</b>	<b>2.56</b>	<b>2.55</b>	<b>2.33</b>	<b>1.89</b>	<b>1.49</b>	<b>1.35</b>	<b>1.02</b>	<b>0.94</b>	<b>3A110</b>
Output Torque (in•lbs)	7459	8596	8267	7047	5264	4825	8990		
Hollow Shaft OHL (lbs)	1120	1120	1120	1120	1120	1120	1120		
Solid Shaft OHL (lbs)	990	990	990	990	990	990	990		
<b>Input HP</b>	<b>2.98</b>	<b>2.81</b>	<b>2.33</b>	<b>1.89</b>	<b>1.49</b>	<b>1.35</b>	<b>1.02</b>	<b>0.94</b>	<b>3A115</b>
Output Torque (in•lbs)	8683	9473	9514	8447	8834	9264	8425	9495	
Hollow Shaft OHL (lbs)	1120	1120	1120	1120	1120	1120	1120	1120	
Solid Shaft OHL (lbs)	990	990	990	990	990	990	990	990	

**2 ...to your SELECTION HP...**

**3 ...to find your FRAME SIZE**

If Overhung Load is present, it must be checked against the capacity of the selection.

For special circumstances in selecting a Frame Size such as:

- Overhung Load
- Thrust Loads
- Radial Loads
- Shock Loading

Consult Appendix, pages 5.2–5.5.



# Configure a Model Number

Speed Reducers  
Nomenclature

### Output Shaft Orientation

Type	Prefix
Horizontal	<b>H</b>
Vertical	<b>V</b>
Vertical Up (Solid Shaft)	<b>W</b>

### Mounting Style

Type	Prefix
Shaft Mount (Hollow Shaft)	<b>Y</b>
Flange (Solid Shaft)	<b>F</b>
Foot (Solid Shaft)	<b>H</b>

### Input Connection

Input Connection	Prefix	
	Reducer	Motor
Free input Shaft		
C-Face Adapter	<b>J</b>	<b>JM</b>
Hollow Input Shaft	<b>X</b>	<b>XM</b>
Shovel Base		<b>M</b>

### Modification

	Prefix
Special	<b>S</b>
Standard	

### Motor HP

(if supplied and/or mounted by Sumitomo; applies only to 1750 RPM)

HP	Prefix
1/8	<b>01</b>
1/4	<b>02</b>
1/3	<b>03</b>
1/2	<b>05</b>
3/4	<b>08</b>
1	<b>1</b>
1 1/2	<b>1H</b>
2	<b>2</b>
3	<b>3</b>
5	<b>5</b>
7 1/2	<b>8</b>
10	<b>10</b>
15	<b>15</b>
20	<b>20</b>
25	<b>25</b>
30	<b>30</b>
40	<b>40</b>

When ordering, the following information should be included:

- NEMA frame size for C-face adapter
- Motor Specification if supplied and/or mounted by Sumitomo (230/460 VAC 60 Hz is supplied, unless otherwise specified)
- Bushing Bore size must be supplied

Optional conduit box positions must be specified, otherwise Y1 is supplied.

### Frame Size

Single Reduction				
3A100	3A140	3B145	3C160	3D165
3A105	3A145	3B160	3C165	3D170
3A110	3B120	3B165	3C170	3D175
3A115	3B125	3C140	3C175	3E170
3A120	3B140	3C145	3D160	3E175
3A125				
Double Reduction				
3A10DA	3B14DA	3C14DC	3D16DB	3D17DC
3A12DA	3B14DB	3C16DA	3D16DC	3E17DA
3A12DB	3C14DA	3C16DB	3D17DA	3E17DB
3B12DA	3C14DB	3D16DA	3D17DB	3E17DC
3B12DB				

### Reducer Specifications

Specification	Suffix
Shovel Base	<b>SB</b>
Torque Limiter	<b>TL</b>

**L H Y J S**

Motor HP (1750 rpm)

**3 A 105**

Frame size

**Y**

O/P shaft direction (shafted model only)

**Y1**

Reducer Specifications

**207**

Ratio

Mounting position and optional specification (as required)

Shaft specification

Modification (Special feature)

Input connection

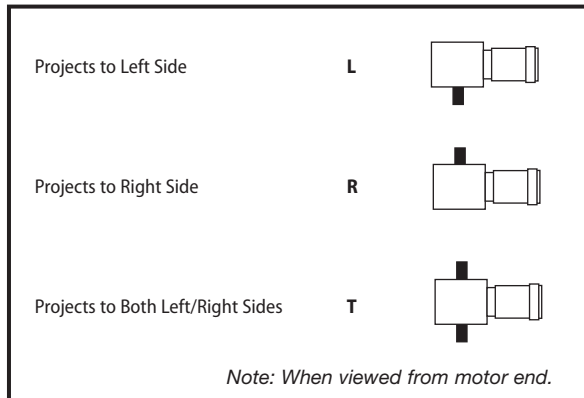
Mounting style

Output shaft orientation

Cyclo BBB product code (always "L")

# Nomenclature

### Output Shaft Direction (Shafted Model Only)



### Shaft Specifications

Input Shaft	OUTPUT SHAFT		Suffix
	Hollow	Solid	
mm	Key (mm)	mm	
Inch	Key (Inch)	Inch	<b>K</b>
mm	Taper Grip		<b>M</b>
Inch	Taper Grip		<b>Y</b>

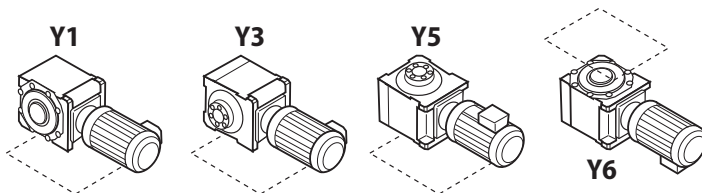
### Nominal and Exact Ratio

BBB with Planetary Input			
Input Ratio	Nominal Ratio	BBB Frame Sz.	Exact Ratio
3	<b>11</b>	3A10	<b>10.500</b>
N/A	<b>N/A</b>	3A11	<b>N/A</b>
3	<b>11</b>	3A12	<b>10.500</b>
3	<b>11</b>	3A14	<b>10.885</b>
3	<b>11</b>	3B12	<b>10.500</b>
3	<b>11</b>	3B14	<b>10.885</b>
3	<b>11</b>	3B16	<b>10.850</b>
3	<b>11</b>	3C14	<b>10.885</b>
3	<b>11</b>	3C17	<b>10.850</b>
3	<b>11</b>	3D16	<b>10.850</b>
3	<b>11</b>	3E17	<b>10.850</b>
5	<b>18</b>	3A10	<b>16.800</b>
N/A	<b>N/A</b>	3A11	<b>N/A</b>
5	<b>18</b>	3A12	<b>17.115</b>
5	<b>18</b>	3A14	<b>17.500</b>
5	<b>18</b>	3B12	<b>17.115</b>
5	<b>18</b>	3B14	<b>17.500</b>
5	<b>18</b>	3B16	<b>17.780</b>
5	<b>18</b>	3C14	<b>17.500</b>
5	<b>18</b>	3C17	<b>17.675</b>
5	<b>18</b>	3D16	<b>17.780</b>
5	<b>18</b>	3E17	<b>17.675</b>

BBB with Cyclo Input Single Reduction			
Input Ratio	Nominal Ratio	BBB Frame Sz.	Exact Ratio
6	<b>21</b>		<b>21.0</b>
8	<b>28</b>		<b>28.0</b>
11	<b>39</b>		<b>38.5</b>
13	<b>46</b>		<b>45.5</b>
15	<b>53</b>		<b>52.5</b>
17	<b>60</b>		<b>59.5</b>
21	<b>74</b>		<b>73.5</b>
25	<b>88</b>	ALL	<b>87.5</b>
29	<b>102</b>		<b>101.5</b>
35	<b>123</b>		<b>122.5</b>
43	<b>151</b>		<b>150.5</b>
51	<b>179</b>		<b>178.5</b>
59	<b>207</b>		<b>206.5</b>
71	<b>249</b>		<b>248.5</b>
87	<b>305</b>		<b>304.5</b>
Double Reduction			
Input Ratio	Nominal Ratio	BBB Frame Sz.	Exact Ratio
104	<b>364</b>		<b>364.0</b>
121	<b>424</b>		<b>423.5</b>
143	<b>501</b>		<b>500.5</b>
165	<b>578</b>		<b>577.5</b>
195	<b>683</b>		<b>682.5</b>
231	<b>809</b>		<b>808.5</b>
273	<b>956</b>		<b>955.5</b>
319	<b>1117</b>		<b>1116.5</b>
377	<b>1320</b>		<b>1319.5</b>
473	<b>1656</b>		<b>1655.5</b>
559	<b>1957</b>		<b>1956.5</b>
649	<b>2272</b>		<b>2271.5</b>
731	<b>2559</b>		<b>2558.5</b>
841	<b>2944</b>	ALL	<b>2943.5</b>
1003	<b>3511</b>		<b>3510.5</b>
1247	<b>4365</b>		<b>4364.5</b>
1479	<b>5177</b>		<b>5176.5</b>
1849	<b>6472</b>		<b>6471.5</b>
2065	<b>7228</b>		<b>7227.5</b>
2537	<b>8880</b>		<b>8879.5</b>
3045	<b>10568</b>		<b>10657.5</b>
3481	<b>12184</b>		<b>12183.5</b>
4437	<b>15530</b>		<b>15529.5</b>
5133	<b>17966</b>		<b>17965.5</b>
6177	<b>21620</b>		<b>21619.5</b>
7569	<b>26492</b>		<b>26491.5</b>

Speed Reducers

Nomenclature



### Mounting Positions

### Nominal and Exact Ratio

#### Nomenclature Example:

**LHYJ – 3B125Y – Y1 – 60**

**L** – Cyclo Bevel Buddybox

**H** – Horizontal O/P

**Y** – Shaft Mount (Hollow Shaft)

**J** – C-Face Input

**3B125** – Frame Size

**Y** – Taper-Grip® Bushing output, inch shaft input

**Y1** – Installation Position

**60** – Ratio

# AGMA Load Classifications

Speed Reducers  
**AGMA Tables**

TYPE OF APPLICATION	TYPE OF LOAD	TYPE OF APPLICATION	TYPE OF LOAD	TYPE OF APPLICATION	TYPE OF LOAD
Agitators		Large (industrial)	M	Paper Mills	
Pure liquids	U	Light (small diameter)	U	Agitators (mixers)	M
Liquids and solids	M	Feeders		Barker, hydraulic	S
Variable-density liquids	M	Apron	M	Barker, mechanical	S
Blowers		Belt	M	Barking drum	S
Centrifugal	U	Disc	U	Beater and pulper	M
Lobe	M	Reciprocating	H	Bleacher	U
Vane	U	Screw	M	Calenders	M
Brewing and Distilling		Food Industry		Calenders, super	H
Bottling machinery	U	Beet slicer	M	Converting machine (except cutters, platers)	M
Brew kettles, cont. duty	U	Cereal cooker	U	Conveyors	U
Cookers, cont. duty	U	Dough mixer	M	Couch	M
Mash tubs, cont. duty	U	Meat grinders	M	Cutters, platers	H
Scale hopper, frequent starts	M	Generators (Not Welding)	U	Cylinders	M
Can Filling Machines	U	Hammer Mills	H	Dryers	M
Cane Knives	M	Hoists		Felt stretcher	M
Car Dumpers	H	Heavy duty	H	Felt whipper	H
Car Pullers	M	Medium duty	M	Jordans	H
Clarifiers	U	Skip	M	Log haul	H
Classifiers	M	Laundry Washers — Reversing	M	Presses	U
Clay Working Machinery		Laundry Tumblers — Reversing	M	Pulp machine reel	M
Brick press	H	Line Shaft		Stock chest	M
Briquette machine	H	Drive processing equipment	M	Suction roll	U
Clay working machinery	M	Light	U	Washers and thickeners	M
Pug mill	M	Other line shafts	U	Winders	U
Compressors		Lumber Industry		Printing Presses	S
Centrifugal	U	Barkers — hydraulic and mechanical	S	Pullers, Barge Haul	H
Lobe	M	Burner conveyor	M	Pumps	
Reciprocating, multi-cylinder	M	Chain Saw and Drag Saw	H	Centrifugal	U
Reciprocating, single-cylinder	H	Chain transfer	H	Proportioning	M
Conveyors — Uniformly Loaded or Fed		Craneway transfer	H	Reciprocating	
Apron	U	De-barking drum	S	Single acting, 3 or more cylinders	M
Assembly	U	Edger feed	H	Double acting, 2 or more cylinders	M
Belt	U	Gang feed	M	Rotary-gear type	U
Bucket	U	Geen chain	M	Rubber and Plastics Industries	
Chain	U	Live rolls	H	Crackers	H
Flight	U	Log haul-lockline	H	Laboratory equipment	M
Oven	U	Log turning device	H	Mixing mills	H
Screw	U	Main log conveyor	H	Refiners	M
Conveyors — Heavy Duty, Not Uniformly Fed		Off bearing rolls	M	Rubber calenders	M
Apron	M	Planer feed chains	M	Rubber mill (2 on line)	M
Assembly	M	Planer floor chains	M	Rubber mill (3 on line)	U
Belt	M	Planer tilting hoist	M	Sheeter	M
Bucket	M	Re-saw merry-go-round conveyor	M	Tire building machines	S
Chain	M	Roll cases	H	Tire and tube press openers	S
Flight	M	Slab conveyor	H	Tubers and strainers	M
Live roll oven	M	Small waste-conveyor-belt	U	Warming mills	M
Reciprocating	H	Small waste-conveyor-chain	M	Sand Muller	M
Screw	M	Sorting table	M	Screens	
Shaker	H	Tipple hoist conveyor	M	Air washing	U
Cranes (Except for Dry Dock Cranes)		Tipple hoist drive	M	Rotary, stone or gravel	M
Main hoists	U	Transfer conveyors	M	Traveling water intake	U
Bridge travel	S	Transfer rolls	M	Sewage Disposal Equipment	
Trolley travel	S	Tray drive	M	Bar screens	U
Crusher		Trimmer feed	M	Chemical fenders	U
Ore	H	Waste conveyor	M	Collectors, circuline or straightline	U
Stone	H	Machine Tools		Dewatering screens	M
Sugar	M	Bending roll	M	Grit collectors	U
Dredges		Notching press, belt driven	S	Scum breakers	M
Cable reels	M	Plate planer	H	Slow or rapid mixers	M
Conveyors	M	Punch press, gear driven	H	Sludge collectors	U
Cutter head drives	H	Tapping machine	H	Thickeners	M
Jig drives	H	Other machine tools		Vacuum filters	M
Maneuvering winches	M	Main drives	M	Slab Pushers	M
Pumps	M	Auxiliary drives	U	Steering Gear	S
Screen drive	H	Metal Mills		Stokers	U
Stackers	M	Draw bench carriage and main drive	M	Sugar Industry	
Utility winches	M	Forming machines	H	Cane knives	M
Dry Dock Cranes	S	Pinch, dryer and scrubber rolls, reversing	S	Crushers	M
Elevators		Slitters	M	Mills	H
Bucket, uniform load	U	Table conveyors, nonreversing		Textile Industry	
Bucket, heavy load	M	Group drives	M	Batchers	M
Bucket, cont.	U	Individual drives	H	Calenders	M
Centrifugal discharge	U	Table conveyors, reversing	S	Cards	M
Escalators	U	Wire drawing and flattening machine	M	Dry cans	M
Freight	M	Wire winding machine	M	Dryers	M
Gravity discharge	U	Mills, Rotary Type		Dyeing machinery	M
Man lifts	S	Ball	M	Knitting machines	S
Passenger	S	Cement kilns	M	Looms	M
Extruders (Plastics)		Dryers and coolers	M	Mangles	M
Blow molders	M	Kilns	M	Nappers	M
Coating	U	Pebble	M	Pads	M
Film	U	Rod, plain and wedge bar	M	Range drives	S
Pipe	U	Tumbling barrels	H	Slashers	M
Pre-plasticizers	M	Mixers		Soapers	M
Rods	U	Concrete mixers, cont.	M	Spinners	M
Sheet	U	Concrete mixers, intermittent	M	Tenter frames	M
Tubing	U	Constant density	U	Washers	M
Fans		Variable density	M	Winders	M
Centrifugal	U	Oil Industry		Windlass	S
Cooling towers	S	Chillers	M		
Forced draft	S	Oil well pumps	S		
Induced draft	S	Paraffin filter press	M		
Large (mine, etc.)	M	Rotary kilns	M		

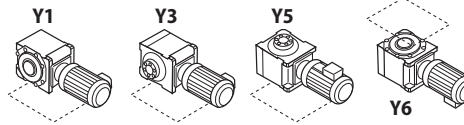
U = Uniform Load      H = Heavy Shock  
M = Moderate Shock    S = Contact Sumitomo

---

This page intentionally left blank.

# Frame Size Selection Tables 60 Hz, 1750 RPM

## Single Reduction Y1, Y3, Y5, Y6 Mounting Positions



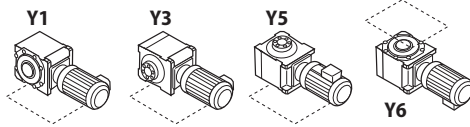
Dimensions on pages 2.22–2.23

Speed Reducers  
Selection Tables

Output RPM	159	97.2	83.3	62.5	44.9	38.0	33.0	29.2	23.6	Frame Size
Ratio	11	18	21	28	39	46	53	60	74	
<b>Input HP</b>	<b>3.15</b>	<b>3.15</b>	<b>3.15</b>	<b>3.15</b>	<b>3.15</b>	<b>3.15</b>	<b>3.15</b>	<b>2.67</b>	<b>2.59</b>	<b>3A100</b>
Output Torque (in•lbs)	1149	1879	2193	2922	4068	4806	5535	5302	6363	
Hollow Shaft OHL (lbs)	1120	1120	1120	1120	1120	1120	1120	1120	1120	
Solid Shaft OHL (lbs)	990	990	990	990	990	990	990	990	990	
<b>Input HP</b>	<b>4.26</b>	<b>4.26</b>	<b>4.26</b>	<b>4.26</b>	<b>4.26</b>	<b>4.26</b>	<b>4.26</b>	<b>3.30</b>	<b>3.14</b>	<b>3A105</b>
Output Torque (in•lbs)	1554	2541	2965	3952	5501	6500	7485	6553	7715	
Hollow Shaft OHL (lbs)	1120	1120	1120	1120	1120	1120	1120	1120	1120	
Solid Shaft OHL (lbs)	990	990	990	990	990	990	990	990	990	
<b>Input HP</b>	-	-	<b>4.76</b>	<b>4.76</b>	<b>4.76</b>	<b>4.76</b>	<b>4.76</b>	<b>4.26</b>	<b>3.65</b>	<b>3A110</b>
Output Torque (in•lbs)	-	-	3313	4416	6147	7263	8364	8459	8968	
Hollow Shaft OHL (lbs)	-	-	1120	1120	1120	1120	1120	1120	1120	
Solid Shaft OHL (lbs)	-	-	990	990	990	990	990	990	990	
<b>Input HP</b>	-	-	<b>5.26</b>	<b>5.26</b>	<b>5.26</b>	<b>5.23</b>	<b>5.23</b>	<b>4.79</b>	<b>3.88</b>	<b>3A115</b>
Output Torque (in•lbs)	-	-	3661	4880	6793	7980	9189	9512	9533	
Hollow Shaft OHL (lbs)	-	-	1120	1120	1120	1120	1120	1120	1120	
Solid Shaft OHL (lbs)	-	-	990	990	990	990	990	990	990	
<b>Input HP</b>	<b>6.80</b>	<b>6.80</b>	<b>6.80</b>	<b>6.80</b>	<b>6.80</b>	-	-	-	-	<b>3A120</b>
Output Torque (in•lbs)	2480	4056	4733	6309	8781	-	-	-	-	
Hollow Shaft OHL (lbs)	1120	1120	1120	1120	1120	-	-	-	-	
Solid Shaft OHL (lbs)	990	990	990	990	990	-	-	-	-	
<b>Input HP</b>	<b>7.79</b>	<b>7.79</b>	<b>7.79</b>	<b>9.32</b>	<b>7.40</b>	<b>6.26</b>	<b>5.43</b>	-	-	<b>3A125</b>
Output Torque (in•lbs)	2841	4647	5422	8646	9556	9552	9541	-	-	
Hollow Shaft OHL (lbs)	1120	1120	1120	1120	1120	1120	1120	-	-	
Solid Shaft OHL (lbs)	990	990	990	990	990	990	990	-	-	
<b>Input HP</b>	<b>17.4</b>	-	-	-	-	-	-	-	-	<b>3A140</b>
Output Torque (in•lbs)	6345	-	-	-	-	-	-	-	-	
Hollow Shaft OHL (lbs)	1120	-	-	-	-	-	-	-	-	
Solid Shaft OHL (lbs)	990	-	-	-	-	-	-	-	-	
<b>Input HP</b>	<b>20.2</b>	<b>14.8</b>	<b>12.3</b>	<b>10.1</b>	-	-	-	-	-	<b>3A145</b>
Output Torque (in•lbs)	7366	8829	8562	9370	-	-	-	-	-	
Hollow Shaft OHL (lbs)	1120	1120	1120	1120	-	-	-	-	-	
Solid Shaft OHL (lbs)	990	990	990	990	-	-	-	-	-	
<b>Input HP</b>	-	-	-	-	-	<b>6.80</b>	<b>6.80</b>	<b>6.80</b>	<b>5.31</b>	<b>3B120</b>
Output Torque (in•lbs)	-	-	-	-	-	10376	11948	13503	13046	
Hollow Shaft OHL (lbs)	-	-	-	-	-	2070	2070	2070	2070	
Solid Shaft OHL (lbs)	-	-	-	-	-	1640	1640	1640	1640	
<b>Input HP</b>	-	-	-	-	<b>7.94</b>	<b>7.94</b>	<b>7.94</b>	<b>7.59</b>	<b>6.54</b>	<b>3B125</b>
Output Torque (in•lbs)	-	-	-	-	10254	12115	13951	15072	16068	
Hollow Shaft OHL (lbs)	-	-	-	-	2070	2070	2070	2070	2070	
Solid Shaft OHL (lbs)	-	-	-	-	1640	1640	1640	1640	1640	
<b>Input HP</b>	-	<b>17.4</b>	<b>17.4</b>	<b>17.4</b>	-	-	-	-	-	<b>3B140</b>
Output Torque (in•lbs)	-	10380	12112	16142	-	-	-	-	-	
Hollow Shaft OHL (lbs)	-	2070	2070	2070	-	-	-	-	-	
Solid Shaft OHL (lbs)	-	1640	1640	1640	-	-	-	-	-	
<b>Input HP</b>	-	<b>20.2</b>	<b>20.2</b>	<b>20.1</b>	<b>14.7</b>	<b>12.5</b>	<b>10.8</b>	<b>9.54</b>	<b>7.72</b>	<b>3B145</b>
Output Torque (in•lbs)	-	12050	14061	18647	18983	19073	18976	18944	18967	
Hollow Shaft OHL (lbs)	-	2070	2070	2070	2070	2070	2070	2070	2070	
Solid Shaft OHL (lbs)	-	1640	1640	1640	1640	1640	1640	1640	1640	
<b>Input HP</b>	<b>27.2</b>	<b>27.2</b>	-	-	-	-	-	-	-	<b>3B160</b>
Output Torque (in•lbs)	9919	16226	-	-	-	-	-	-	-	
Hollow Shaft OHL (lbs)	2070	2070	-	-	-	-	-	-	-	
Solid Shaft OHL (lbs)	1640	1640	-	-	-	-	-	-	-	



# 60 Hz, 1750 RPM Frame Size Selection Tables



## Single Reduction Y1, Y3, Y5, Y6 Mounting Positions

Dimensions on pages 2.22–2.23

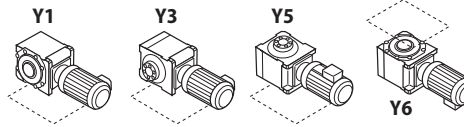
Output RPM	19.9	17.2	14.2	11.6	9.78	8.45	7.03	5.74	4.20	Frame Size
Ratio	88	102	123	151	179	207	249	305	417	
<b>Input HP</b>	<b>1.70</b>	<b>1.62</b>	<b>1.31</b>	<b>1.05</b>	<b>0.751</b>	<b>0.692</b>	<b>0.585</b>	<b>0.581</b>	<b>0.282</b>	<b>3A100</b>
Output Torque (in•lbs)	4953	5461	5349	5248	4452	4748	4832	5869	3893	
Hollow Shaft OHL (lbs)	1120	1120	1120	1120	1120	1120	1120	1120	1120	
Solid Shaft OHL (lbs)	990	990	990	990	990	990	990	990	990	
<b>Input HP</b>	<b>2.24</b>	<b>2.13</b>	<b>1.61</b>	<b>1.45</b>	<b>1.04</b>	<b>0.949</b>	<b>0.752</b>	<b>0.758</b>	<b>0.384</b>	<b>3A105</b>
Output Torque (in•lbs)	6527	7180	6574	7248	6166	6512	6211	7657	5301	
Hollow Shaft OHL (lbs)	1120	1120	1120	1120	1120	1120	1120	1120	1120	
Solid Shaft OHL (lbs)	990	990	990	990	990	990	990	990	990	
<b>Input HP</b>	<b>2.56</b>	<b>2.55</b>	<b>2.01</b>	<b>1.74</b>	<b>1.27</b>	<b>1.15</b>	<b>0.897</b>	<b>0.886</b>	-	<b>3A110</b>
Output Torque (in•lbs)	7459	8596	8207	8697	7529	7891	7409	8950	-	
Hollow Shaft OHL (lbs)	1120	1120	1120	1120	1120	1120	1120	1120	-	
Solid Shaft OHL (lbs)	990	990	990	990	990	990	990	990	-	
<b>Input HP</b>	<b>2.98</b>	<b>2.81</b>	<b>2.33</b>	<b>1.89</b>	<b>1.49</b>	<b>1.35</b>	<b>1.02</b>	<b>0.936</b>	-	<b>3A115</b>
Output Torque (in•lbs)	8683	9473	9514	9447	8834	9264	8425	9455	-	
Hollow Shaft OHL (lbs)	1120	1120	1120	1120	1120	1120	1120	1120	-	
Solid Shaft OHL (lbs)	990	990	990	990	990	990	990	990	-	
<b>Input HP</b>	-	-	-	-	-	-	-	-	-	<b>3A120</b>
Output Torque (in•lbs)	-	-	-	-	-	-	-	-	-	
Hollow Shaft OHL (lbs)	-	-	-	-	-	-	-	-	-	
Solid Shaft OHL (lbs)	-	-	-	-	-	-	-	-	-	
<b>Input HP</b>	<b>3.26</b>	-	-	-	<b>1.60</b>	<b>1.38</b>	<b>1.15</b>	-	-	<b>3A125</b>
Output Torque (in•lbs)	9499	-	-	-	9486	9469	9499	-	-	
Hollow Shaft OHL (lbs)	1120	-	-	-	1120	1120	1120	-	-	
Solid Shaft OHL (lbs)	990	-	-	-	990	990	990	-	-	
<b>Input HP</b>	-	-	-	-	-	-	-	-	-	<b>3A140</b>
Output Torque (in•lbs)	-	-	-	-	-	-	-	-	-	
Hollow Shaft OHL (lbs)	-	-	-	-	-	-	-	-	-	
Solid Shaft OHL (lbs)	-	-	-	-	-	-	-	-	-	
<b>Input HP</b>	-	-	-	-	-	-	-	-	-	<b>3A145</b>
Output Torque (in•lbs)	-	-	-	-	-	-	-	-	-	
Hollow Shaft OHL (lbs)	-	-	-	-	-	-	-	-	-	
Solid Shaft OHL (lbs)	-	-	-	-	-	-	-	-	-	
<b>Input HP</b>	<b>4.14</b>	<b>4.01</b>	<b>3.34</b>	<b>2.56</b>	<b>2.31</b>	<b>1.74</b>	<b>1.28</b>	<b>1.27</b>	-	<b>3B120</b>
Output Torque (in•lbs)	12063	13518	13638	12796	13695	11940	10572	12829	-	
Hollow Shaft OHL (lbs)	2070	2070	2070	2070	2070	2070	2070	2070	-	
Solid Shaft OHL (lbs)	1640	1640	1640	1640	1640	1640	1640	1640	-	
<b>Input HP</b>	<b>5.31</b>	<b>5.06</b>	<b>4.26</b>	<b>3.19</b>	<b>3.06</b>	<b>2.17</b>	<b>1.61</b>	<b>1.52</b>	-	<b>3B125</b>
Output Torque (in•lbs)	15472	17058	17395	15945	18142	14890	13298	15354	-	
Hollow Shaft OHL (lbs)	2070	2070	2070	2070	2070	2070	2070	2070	-	
Solid Shaft OHL (lbs)	1640	1640	1640	1640	1640	1640	1640	1640	-	
<b>Input HP</b>	-	-	-	-	-	-	-	-	-	<b>3B140</b>
Output Torque (in•lbs)	-	-	-	-	-	-	-	-	-	
Hollow Shaft OHL (lbs)	-	-	-	-	-	-	-	-	-	
Solid Shaft OHL (lbs)	-	-	-	-	-	-	-	-	-	
<b>Input HP</b>	<b>6.49</b>	<b>5.59</b>	<b>4.63</b>	<b>3.77</b>	<b>3.18</b>	<b>2.75</b>	<b>2.28</b>	<b>1.86</b>	-	<b>3B145</b>
Output Torque (in•lbs)	18910	18844	18906	18844	18853	18870	18832	18789	-	
Hollow Shaft OHL (lbs)	2070	2070	2070	2070	2070	2070	2070	2070	-	
Solid Shaft OHL (lbs)	1640	1640	1640	1640	1640	1640	1640	1640	-	
<b>Input HP</b>	-	-	-	-	-	-	-	-	-	<b>3B160</b>
Output Torque (in•lbs)	-	-	-	-	-	-	-	-	-	
Hollow Shaft OHL (lbs)	-	-	-	-	-	-	-	-	-	
Solid Shaft OHL (lbs)	-	-	-	-	-	-	-	-	-	

Speed Reducers

Selection Tables

# Frame Size Selection Tables 60 Hz, 1750 RPM

## Single Reduction Y1, Y3, Y5, Y6 Mounting Positions

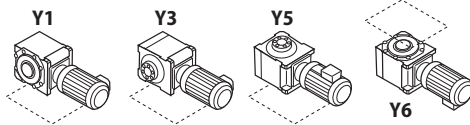


Dimensions on pages 2.22–2.23

Speed Reducers  
Selection Tables

Output RPM	159	97.2	83.3	62.5	44.9	38.0	33.0	29.2	23.6	Frame Size
Ratio	11	18	21	28	39	46	53	60	74	
<b>Input HP</b>	<b>29.4</b>	<b>29.5</b>	<b>24.8</b>	-	-	-	-	-	-	<b>3B165</b>
Output Torque (in•lbs)	10721	17598	17263	-	-	-	-	-	-	
Hollow Shaft OHL (lbs)	2070	2070	2070	-	-	-	-	-	-	
Solid Shaft OHL (lbs)	1640	1640	1640	-	-	-	-	-	-	
<b>Input HP</b>	-	-	-	-	<b>17.4</b>	<b>17.4</b>	<b>16.1</b>	<b>13.5</b>	<b>11.6</b>	<b>3C140</b>
Output Torque (in•lbs)	-	-	-	-	22470	26550	28289	26807	28500	
Hollow Shaft OHL (lbs)	-	-	-	-	3480	3480	3480	3480	3480	
Solid Shaft OHL (lbs)	-	-	-	-	2850	2850	2850	2850	2850	
<b>Input HP</b>	-	-	-	<b>20.2</b>	<b>20.2</b>	<b>20.2</b>	<b>19.6</b>	<b>16.1</b>	<b>14.8</b>	<b>3C145</b>
Output Torque (in•lbs)	-	-	-	18740	26086	30823	34438	31970	36362	
Hollow Shaft OHL (lbs)	-	-	-	3480	3480	3480	3480	3480	3480	
Solid Shaft OHL (lbs)	-	-	-	2850	2850	2850	2850	2850	2850	
<b>Input HP</b>	-	-	<b>27.2</b>	<b>26.4</b>	<b>26.4</b>	-	-	<b>17.6</b>	-	<b>3C160</b>
Output Torque (in•lbs)	-	-	18933	24492	34092	-	-	34949	-	
Hollow Shaft OHL (lbs)	-	-	3480	3480	3480	-	-	3480	-	
Solid Shaft OHL (lbs)	-	-	2850	2850	2850	-	-	2850	-	
<b>Input HP</b>	-	-	<b>32.3</b>	<b>32.3</b>	<b>32.3</b>	<b>24.9</b>	<b>21.6</b>	<b>19.1</b>	<b>15.4</b>	<b>3C165</b>
Output Torque (in•lbs)	-	-	22483	29966	41712	37994	37953	37927	37836	
Hollow Shaft OHL (lbs)	-	-	3480	3480	3480	3480	3480	3480	3480	
Solid Shaft OHL (lbs)	-	-	2850	2850	2850	2850	2850	2850	2850	
<b>Input HP</b>	<b>37.0</b>	<b>37.0</b>	<b>37.0</b>	<b>37.0</b>	-	-	-	-	-	<b>3C170</b>
Output Torque (in•lbs)	13493	22072	25755	34326	-	-	-	-	-	
Hollow Shaft OHL (lbs)	3480	3480	3480	3480	-	-	-	-	-	
Solid Shaft OHL (lbs)	2850	2850	2850	2850	-	-	-	-	-	
<b>Input HP</b>	<b>40.2</b>	<b>40.3</b>	<b>40.3</b>	<b>40.2</b>	-	-	-	-	-	<b>3C175</b>
Output Torque (in•lbs)	14660	24040	28052	37295	-	-	-	-	-	
Hollow Shaft OHL (lbs)	3480	3480	3480	3480	-	-	-	-	-	
Solid Shaft OHL (lbs)	2850	2850	2850	2850	-	-	-	-	-	
<b>Input HP</b>	-	-	-	-	-	<b>26.4</b>	<b>25.1</b>	-	<b>17.3</b>	<b>3D160</b>
Output Torque (in•lbs)	-	-	-	-	-	40283	44102	-	42504	
Hollow Shaft OHL (lbs)	-	-	-	-	-	4810	4810	-	4810	
Solid Shaft OHL (lbs)	-	-	-	-	-	3930	3930	-	3930	
<b>Input HP</b>	-	-	-	-	<b>32.3</b>	<b>30.3</b>	<b>30.1</b>	<b>25.2</b>	<b>21.6</b>	<b>3D165</b>
Output Torque (in•lbs)	-	-	-	-	41712	46234	52888	50040	53069	
Hollow Shaft OHL (lbs)	-	-	-	-	4810	4810	4810	4810	4810	
Solid Shaft OHL (lbs)	-	-	-	-	3930	3930	3930	3930	3930	
<b>Input HP</b>	-	-	-	-	<b>37.0</b>	<b>36.6</b>	<b>34.2</b>	<b>26.4</b>	-	<b>3D170</b>
Output Torque (in•lbs)	-	-	-	-	47781	55847	60091	52423	-	
Hollow Shaft OHL (lbs)	-	-	-	-	4810	4810	4810	4810	-	
Solid Shaft OHL (lbs)	-	-	-	-	3930	3930	3930	3930	-	
<b>Input HP</b>	-	-	<b>40.4</b>	<b>40.4</b>	<b>40.2</b>	<b>40.2</b>	<b>36.7</b>	<b>32.3</b>	<b>26.2</b>	<b>3D175</b>
Output Torque (in•lbs)	-	-	28121	37480	51914	61340	64484	64139	64371	
Hollow Shaft OHL (lbs)	-	-	4810	4810	4810	4810	4810	4810	4810	
Solid Shaft OHL (lbs)	-	-	3930	3930	3930	3930	3930	3930	3930	
<b>Input HP</b>	-	-	-	-	-	-	-	-	-	<b>3E170</b>
Output Torque (in•lbs)	-	-	-	-	-	-	-	-	-	
Hollow Shaft OHL (lbs)	-	-	-	-	-	-	-	-	-	
Solid Shaft OHL (lbs)	-	-	-	-	-	-	-	-	-	
<b>Input HP</b>	-	-	-	-	<b>40.4</b>	<b>40.4</b>	<b>40.2</b>	<b>32.3</b>	<b>29.5</b>	<b>3E175</b>
Output Torque (in•lbs)	-	-	-	-	52172	61645	70634	64139	72479	
Hollow Shaft OHL (lbs)	-	-	-	-	5170	5170	5170	5170	5170	
Solid Shaft OHL (lbs)	-	-	-	-	4110	4110	4110	4110	4110	

## 60 Hz, 1750 RPM Frame Size Selection Tables

Single Reduction  
Y1, Y3, Y5, Y6 Mounting Positions

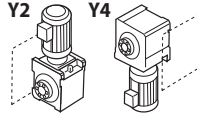
Dimensions on pages 2.22–2.23

Output RPM	19.9	17.2	14.2	11.6	9.8	8.45	7.03	5.74	4.20	Frame Size
Ratio	88	102	123	151	179	207	249	305	417	
<b>Input HP</b>	-	-	-	-	-	-	-	-	-	<b>3B165</b>
Output Torque (in•lbs)	-	-	-	-	-	-	-	-	-	
Hollow Shaft OHL (lbs)	-	-	-	-	-	-	-	-	-	
Solid Shaft OHL (lbs)	-	-	-	-	-	-	-	-	-	
<b>Input HP</b>	<b>9.24</b>	<b>7.98</b>	<b>6.99</b>	<b>5.28</b>	<b>4.60</b>	<b>3.97</b>	<b>3.26</b>	<b>2.66</b>	-	<b>3C140</b>
Output Torque (in•lbs)	26923	26901	28542	26392	27272	27242	26888	26870	-	
Hollow Shaft OHL (lbs)	3480	3480	3480	3480	3480	3480	3480	3480	-	
Solid Shaft OHL (lbs)	2850	2850	2850	2850	2850	2850	2850	2850	-	
<b>Input HP</b>	<b>10.6</b>	<b>10.1</b>	<b>9.27</b>	<b>7.23</b>	<b>5.66</b>	<b>4.89</b>	<b>4.06</b>	<b>3.33</b>	-	<b>3C145</b>
Output Torque (in•lbs)	30885	34048	37852	36139	33557	33555	33487	33638	-	
Hollow Shaft OHL (lbs)	3480	3480	3480	3480	3480	3480	3480	3480	-	
Solid Shaft OHL (lbs)	2850	2850	2850	2850	2850	2850	2850	2850	-	
<b>Input HP</b>	-	-	-	-	-	-	-	-	-	<b>3C160</b>
Output Torque (in•lbs)	-	-	-	-	-	-	-	-	-	
Hollow Shaft OHL (lbs)	-	-	-	-	-	-	-	-	-	
Solid Shaft OHL (lbs)	-	-	-	-	-	-	-	-	-	
<b>Input HP</b>	<b>13.0</b>	<b>11.2</b>	<b>9.27</b>	<b>7.54</b>	<b>6.36</b>	<b>5.50</b>	<b>4.57</b>	<b>3.73</b>	-	<b>3C165</b>
Output Torque (in•lbs)	37878	37756	37852	37689	37707	37740	37693	37679	-	
Hollow Shaft OHL (lbs)	3480	3480	3480	3480	3480	3480	3480	3480	-	
Solid Shaft OHL (lbs)	2850	2850	2850	2850	2850	2850	2850	2850	-	
<b>Input HP</b>	-	-	-	-	-	-	-	-	-	<b>3C170</b>
Output Torque (in•lbs)	-	-	-	-	-	-	-	-	-	
Hollow Shaft OHL (lbs)	-	-	-	-	-	-	-	-	-	
Solid Shaft OHL (lbs)	-	-	-	-	-	-	-	-	-	
<b>Input HP</b>	-	-	-	-	-	-	-	-	-	<b>3C175</b>
Output Torque (in•lbs)	-	-	-	-	-	-	-	-	-	
Hollow Shaft OHL (lbs)	-	-	-	-	-	-	-	-	-	
Solid Shaft OHL (lbs)	-	-	-	-	-	-	-	-	-	
<b>Input HP</b>	<b>13.2</b>	<b>14.1</b>	<b>13.0</b>	<b>10.0</b>	<b>7.71</b>	<b>5.93</b>	<b>4.65</b>	<b>4.65</b>	-	<b>3D160</b>
Output Torque (in•lbs)	38461	47533	53083	49985	45711	40691	38353	46972	-	
Hollow Shaft OHL (lbs)	4810	4810	4810	4810	4810	4810	4810	4810	-	
Solid Shaft OHL (lbs)	3930	3930	3930	3930	3930	3930	3930	3930	-	
<b>Input HP</b>	<b>20.2</b>	<b>14.9</b>	<b>15.3</b>	<b>10.6</b>	<b>10.1</b>	<b>7.71</b>	<b>7.58</b>	<b>5.23</b>	-	<b>3D165</b>
Output Torque (in•lbs)	58857	50229	62475	52984	59880	52905	62519	52831	-	
Hollow Shaft OHL (lbs)	4810	4810	4810	4810	4810	4810	4810	4810	-	
Solid Shaft OHL (lbs)	3930	3930	3930	3930	3930	3930	3930	3930	-	
<b>Input HP</b>	<b>21.2</b>	-	-	-	-	-	-	-	-	<b>3D170</b>
Output Torque (in•lbs)	61771	-	-	-	-	-	-	-	-	
Hollow Shaft OHL (lbs)	4810	-	-	-	-	-	-	-	-	
Solid Shaft OHL (lbs)	3930	-	-	-	-	-	-	-	-	
<b>Input HP</b>	<b>22.0</b>	<b>19.0</b>	<b>15.7</b>	<b>12.8</b>	<b>10.8</b>	<b>9.33</b>	<b>7.75</b>	<b>6.32</b>	-	<b>3D175</b>
Output Torque (in•lbs)	64102	64051	64108	63981	64030	64021	63922	63842	-	
Hollow Shaft OHL (lbs)	4810	4810	4810	4810	4810	4810	4810	4810	-	
Solid Shaft OHL (lbs)	3930	3930	3930	3930	3930	3930	3930	3930	-	
<b>Input HP</b>	-	<b>19.2</b>	<b>16.1</b>	<b>13.1</b>	<b>11.3</b>	<b>9.59</b>	<b>7.94</b>	<b>6.45</b>	-	<b>3E170</b>
Output Torque (in•lbs)	-	64725	65741	65481	66995	65806	65489	65155	-	
Hollow Shaft OHL (lbs)	-	5170	5170	5170	5170	5170	5170	5170	-	
Solid Shaft OHL (lbs)	-	4110	4110	4110	4110	4110	4110	4110	-	
<b>Input HP</b>	<b>24.8</b>	<b>21.4</b>	<b>20.2</b>	<b>15.2</b>	<b>14.4</b>	<b>11.1</b>	<b>9.59</b>	<b>7.54</b>	-	<b>3E175</b>
Output Torque (in•lbs)	72260	72142	82483	75978	85374	76167	79098	76166	-	
Hollow Shaft OHL (lbs)	5170	5170	5170	5170	5170	5170	5170	5170	-	
Solid Shaft OHL (lbs)	4110	4110	4110	4110	4110	4110	4110	4110	-	

Speed  
ReducersSelection  
Tables

# Frame Size Selection Tables 60 Hz, 1750 RPM

## Single Reduction Y2, Y4 Mounting Positions

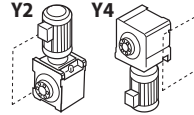


Dimensions on pages 2.22–2.23

Speed Reducers  
Selection Tables

Output RPM	159	97.2	83.3	62.5	44.9	38.0	33.0	29.2	23.6	Frame Size
Ratio	11	18	21	28	39	46	53	60	74	
<b>Input HP</b>	<b>3.15</b>	<b>3.15</b>	<b>3.15</b>	<b>3.15</b>	<b>3.15</b>	<b>3.15</b>	<b>3.15</b>	<b>2.67</b>	<b>2.59</b>	<b>3A100</b>
Output Torque (in•lbs)	1149	1879	2193	2922	4068	4806	5535	5302	6363	
Hollow Shaft OHL (lbs)	1120	1120	1120	1120	1120	1120	1120	1120	1120	
Solid Shaft OHL (lbs)	990	990	990	990	990	990	990	990	990	
<b>Input HP</b>	<b>4.26</b>	<b>4.26</b>	<b>4.26</b>	<b>4.26</b>	<b>4.26</b>	<b>4.26</b>	<b>4.26</b>	<b>3.30</b>	<b>3.14</b>	<b>3A105</b>
Output Torque (in•lbs)	1554	2541	2965	3952	5501	6500	7485	6553	7715	
Hollow Shaft OHL (lbs)	1120	1120	1120	1120	1120	1120	1120	1120	1120	
Solid Shaft OHL (lbs)	990	990	990	990	990	990	990	990	990	
<b>Input HP</b>	-	-	<b>4.76</b>	<b>4.76</b>	<b>4.76</b>	<b>4.76</b>	<b>4.76</b>	<b>4.26</b>	<b>3.65</b>	<b>3A110</b>
Output Torque (in•lbs)	-	-	3313	4416	6147	7263	8364	8459	8968	
Hollow Shaft OHL (lbs)	-	-	1120	1120	1120	1120	1120	1120	1120	
Solid Shaft OHL (lbs)	-	-	990	990	990	990	990	990	990	
<b>Input HP</b>	-	-	<b>5.26</b>	<b>5.26</b>	<b>5.26</b>	<b>5.23</b>	<b>5.23</b>	<b>4.79</b>	<b>3.88</b>	<b>3A115</b>
Output Torque (in•lbs)	-	-	3661	4880	6793	7980	9189	9512	9533	
Hollow Shaft OHL (lbs)	-	-	1120	1120	1120	1120	1120	1120	1120	
Solid Shaft OHL (lbs)	-	-	990	990	990	990	990	990	990	
<b>Input HP</b>	<b>6.80</b>	<b>6.80</b>	<b>6.80</b>	<b>6.80</b>	<b>6.80</b>	-	-	-	-	<b>3A120</b>
Output Torque (in•lbs)	2480	4056	4733	6309	8781	-	-	-	-	
Hollow Shaft OHL (lbs)	1120	1120	1120	1120	1120	-	-	-	-	
Solid Shaft OHL (lbs)	990	990	990	990	990	-	-	-	-	
<b>Input HP</b>	<b>7.79</b>	<b>7.79</b>	<b>7.79</b>	<b>9.32</b>	<b>7.40</b>	<b>6.26</b>	<b>5.43</b>	-	-	<b>3A125</b>
Output Torque (in•lbs)	2841	4647	5422	8646	9556	9552	9541	-	-	
Hollow Shaft OHL (lbs)	1120	1120	1120	1120	1120	1120	1120	-	-	
Solid Shaft OHL (lbs)	990	990	990	990	990	990	990	-	-	
<b>Input HP</b>	<b>12.7</b>	<b>12.7</b>	-	-	-	-	-	-	-	<b>3A140</b>
Output Torque (in•lbs)	4631	7576	-	-	-	-	-	-	-	
Hollow Shaft OHL (lbs)	1120	1120	-	-	-	-	-	-	-	
Solid Shaft OHL (lbs)	990	990	-	-	-	-	-	-	-	
<b>Input HP</b>	<b>14.8</b>	<b>14.8</b>	<b>12.3</b>	<b>10.1</b>	-	-	-	-	-	<b>3A145</b>
Output Torque (in•lbs)	5397	8829	8562	9370	-	-	-	-	-	
Hollow Shaft OHL (lbs)	1120	1120	1120	1120	-	-	-	-	-	
Solid Shaft OHL (lbs)	990	990	990	990	-	-	-	-	-	
<b>Input HP</b>	-	-	-	-	-	<b>6.80</b>	<b>6.80</b>	<b>6.80</b>	<b>5.31</b>	<b>3B120</b>
Output Torque (in•lbs)	-	-	-	-	-	10376	11948	13503	13046	
Hollow Shaft OHL (lbs)	-	-	-	-	-	2070	2070	2070	2070	
Solid Shaft OHL (lbs)	-	-	-	-	-	1640	1640	1640	1640	
<b>Input HP</b>	-	-	-	-	<b>7.94</b>	<b>7.94</b>	<b>7.94</b>	<b>7.59</b>	<b>6.54</b>	<b>3B125</b>
Output Torque (in•lbs)	-	-	-	-	10254	12115	13951	15072	16068	
Hollow Shaft OHL (lbs)	-	-	-	-	2070	2070	2070	2070	2070	
Solid Shaft OHL (lbs)	-	-	-	-	1640	1640	1640	1640	1640	
<b>Input HP</b>	-	-	-	-	-	-	-	-	-	<b>3B140</b>
Output Torque (in•lbs)	-	-	-	-	-	-	-	-	-	
Hollow Shaft OHL (lbs)	-	-	-	-	-	-	-	-	-	
Solid Shaft OHL (lbs)	-	-	-	-	-	-	-	-	-	
<b>Input HP</b>	-	-	<b>14.9</b>	<b>14.9</b>	<b>14.7</b>	<b>10.2</b>	<b>10.2</b>	<b>7.46</b>	<b>7.46</b>	<b>3B145</b>
Output Torque (in•lbs)	-	-	10372	13823	18983	15564	17922	14813	18329	
Hollow Shaft OHL (lbs)	-	-	2070	2070	2070	2070	2070	2070	2070	
Solid Shaft OHL (lbs)	-	-	1640	1640	1640	1640	1640	1640	1640	
<b>Input HP</b>	<b>16.9</b>	<b>16.9</b>	-	-	-	-	-	-	-	<b>3B160</b>
Output Torque (in•lbs)	6163	10081	-	-	-	-	-	-	-	
Hollow Shaft OHL (lbs)	2070	2070	-	-	-	-	-	-	-	
Solid Shaft OHL (lbs)	1640	1640	-	-	-	-	-	-	-	

## 60 Hz, 1750 RPM Frame Size Selection Tables

Single Reduction  
Y2, Y4 Mounting Positions

Dimensions on pages 2.22–2.23

Output RPM	19.9	17.2	14.2	11.6	9.8	8.45	7.03	5.74	4.20	Frame Size
Ratio	88	102	123	151	179	207	249	305	417	
<b>Input HP</b>	<b>1.70</b>	<b>1.62</b>	<b>1.31</b>	<b>1.05</b>	<b>0.751</b>	<b>0.692</b>	<b>0.585</b>	<b>0.581</b>	<b>0.282</b>	<b>3A100</b>
Output Torque (in•lbs)	4953	5461	5349	5248	4452	4748	4825	5866	3893	
Hollow Shaft OHL (lbs)	1120	1120	1120	1120	1120	1120	1120	1120	1120	
Solid Shaft OHL (lbs)	990	990	990	990	990	990	990	990	990	
<b>Input HP</b>	<b>2.24</b>	<b>2.13</b>	<b>1.61</b>	<b>1.45</b>	<b>1.04</b>	<b>0.950</b>	<b>0.750</b>	<b>0.760</b>	<b>0.384</b>	<b>3A105</b>
Output Torque (in•lbs)	6527	7180	6574	7248	6166	6519	6186	7673	5301	
Hollow Shaft OHL (lbs)	1120	1120	1120	1120	1120	1120	1120	1120	1120	
Solid Shaft OHL (lbs)	990	990	990	990	990	990	990	990	990	
<b>Input HP</b>	<b>2.56</b>	<b>2.55</b>	<b>2.01</b>	<b>1.74</b>	<b>1.27</b>	<b>1.15</b>	<b>0.900</b>	<b>0.890</b>	-	<b>3A110</b>
Output Torque (in•lbs)	7459	8596	8207	8697	7529	7891	7423	8986	-	
Hollow Shaft OHL (lbs)	1120	1120	1120	1120	1120	1120	1120	1120	-	
Solid Shaft OHL (lbs)	990	990	990	990	990	990	990	990	-	
<b>Input HP</b>	<b>2.98</b>	<b>2.81</b>	<b>2.33</b>	<b>1.89</b>	<b>1.49</b>	<b>1.35</b>	<b>1.02</b>	<b>0.940</b>	-	<b>3A115</b>
Output Torque (in•lbs)	8683	9473	9514	9447	8834	9264	8413	9491	-	
Hollow Shaft OHL (lbs)	1120	1120	1120	1120	1120	1120	1120	1120	-	
Solid Shaft OHL (lbs)	990	990	990	990	990	990	990	990	-	
<b>Input HP</b>	-	-	-	-	-	-	-	-	-	<b>3A120</b>
Output Torque (in•lbs)	-	-	-	-	-	-	-	-	-	
Hollow Shaft OHL (lbs)	-	-	-	-	-	-	-	-	-	
Solid Shaft OHL (lbs)	-	-	-	-	-	-	-	-	-	
<b>Input HP</b>	<b>3.26</b>	-	-	-	<b>1.60</b>	<b>1.38</b>	<b>1.15</b>	-	-	<b>3A125</b>
Output Torque (in•lbs)	9499	-	-	-	9486	9469	9485	-	-	
Hollow Shaft OHL (lbs)	1120	-	-	-	1120	1120	1120	-	-	
Solid Shaft OHL (lbs)	990	-	-	-	990	990	990	-	-	
<b>Input HP</b>	-	-	-	-	-	-	-	-	-	<b>3A140</b>
Output Torque (in•lbs)	-	-	-	-	-	-	-	-	-	
Hollow Shaft OHL (lbs)	-	-	-	-	-	-	-	-	-	
Solid Shaft OHL (lbs)	-	-	-	-	-	-	-	-	-	
<b>Input HP</b>	-	-	-	-	-	-	-	-	-	<b>3A145</b>
Output Torque (in•lbs)	-	-	-	-	-	-	-	-	-	
Hollow Shaft OHL (lbs)	-	-	-	-	-	-	-	-	-	
Solid Shaft OHL (lbs)	-	-	-	-	-	-	-	-	-	
<b>Input HP</b>	<b>4.14</b>	<b>4.01</b>	<b>3.34</b>	<b>2.56</b>	<b>2.31</b>	<b>1.74</b>	<b>1.28</b>	<b>1.27</b>	-	<b>3B120</b>
Output Torque (in•lbs)	12063	13518	13638	12796	13695	11940	10557	12822	-	
Hollow Shaft OHL (lbs)	2070	2070	2070	2070	2070	2070	2070	2070	-	
Solid Shaft OHL (lbs)	1640	1640	1640	1640	1640	1640	1640	1640	-	
<b>Input HP</b>	<b>5.31</b>	<b>5.06</b>	<b>4.26</b>	<b>3.19</b>	<b>3.06</b>	<b>2.17</b>	<b>1.61</b>	<b>1.52</b>	-	<b>3B125</b>
Output Torque (in•lbs)	15472	17058	17395	15945	18142	14890	13279	15346	-	
Hollow Shaft OHL (lbs)	2070	2070	2070	2070	2070	2070	2070	2070	-	
Solid Shaft OHL (lbs)	1640	1640	1640	1640	1640	1640	1640	1640	-	
<b>Input HP</b>	-	-	-	-	-	-	-	-	-	<b>3B140</b>
Output Torque (in•lbs)	-	-	-	-	-	-	-	-	-	
Hollow Shaft OHL (lbs)	-	-	-	-	-	-	-	-	-	
Solid Shaft OHL (lbs)	-	-	-	-	-	-	-	-	-	
<b>Input HP</b>	<b>6.49</b>	-	<b>4.63</b>	-	-	<b>2.75</b>	<b>2.04</b>	<b>1.86</b>	-	<b>3B145</b>
Output Torque (in•lbs)	18910	-	18910	-	-	18870	16826	18779	-	
Hollow Shaft OHL (lbs)	2070	-	2070	-	-	2070	2070	2070	-	
Solid Shaft OHL (lbs)	1640	-	1640	-	-	1640	1640	1640	-	
<b>Input HP</b>	-	-	-	-	-	-	-	-	-	<b>3B160</b>
Output Torque (in•lbs)	-	-	-	-	-	-	-	-	-	
Hollow Shaft OHL (lbs)	-	-	-	-	-	-	-	-	-	
Solid Shaft OHL (lbs)	-	-	-	-	-	-	-	-	-	

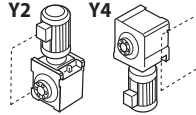
Speed Reducers

Selection Tables



# Frame Size Selection Tables 60 Hz, 1750 RPM

## Single Reduction Y2, Y4 Mounting Positions

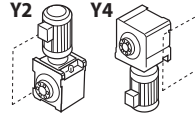


Dimensions on pages 2.22–2.23

Speed Reducers  
Selection Tables

Output RPM	159	97.2	83.3	62.5	44.9	38.0	33.0	29.2	23.6	Frame Size
Ratio	11	18	21	28	39	46	53	60	74	
<b>Input HP</b>	<b>20.1</b>	<b>20.1</b>	–	<b>20.1</b>	–	<b>12.5</b>	<b>10.8</b>	<b>9.54</b>	<b>7.72</b>	<b>3B165</b>
Output Torque (in•lbs)	7330	11990	–	18647	–	19073	18976	18944	18967	
Hollow Shaft OHL (lbs)	2070	2070	–	2070	–	2070	2070	2070	2070	
Solid Shaft OHL (lbs)	1640	1640	–	1640	–	1640	1640	1640	1640	
<b>Input HP</b>	–	–	–	–	–	–	–	–	–	<b>3C140</b>
Output Torque (in•lbs)	–	–	–	–	–	–	–	–	–	
Hollow Shaft OHL (lbs)	–	–	–	–	–	–	–	–	–	
Solid Shaft OHL (lbs)	–	–	–	–	–	–	–	–	–	
<b>Input HP</b>	–	–	<b>14.9</b>	–	<b>14.9</b>	–	–	–	–	<b>3C145</b>
Output Torque (in•lbs)	–	–	10372	–	19242	–	–	–	–	
Hollow Shaft OHL (lbs)	–	–	3480	–	3480	–	–	–	–	
Solid Shaft OHL (lbs)	–	–	2850	–	2850	–	–	–	–	
<b>Input HP</b>	–	–	–	–	–	–	–	–	–	<b>3C160</b>
Output Torque (in•lbs)	–	–	–	–	–	–	–	–	–	
Hollow Shaft OHL (lbs)	–	–	–	–	–	–	–	–	–	
Solid Shaft OHL (lbs)	–	–	–	–	–	–	–	–	–	
<b>Input HP</b>	–	–	–	<b>20.4</b>	<b>20.4</b>	<b>14.9</b>	<b>14.9</b>	<b>14.9</b>	<b>10.2</b>	<b>3C165</b>
Output Torque (in•lbs)	–	–	–	18926	26344	22735	26180	29587	25060	
Hollow Shaft OHL (lbs)	–	–	–	3480	3480	3480	3480	3480	3480	
Solid Shaft OHL (lbs)	–	–	–	2850	2850	2850	2850	2850	2850	
<b>Input HP</b>	<b>27.1</b>	<b>27.1</b>	–	–	–	–	–	–	–	<b>3C170</b>
Output Torque (in•lbs)	9883	16166	–	–	–	–	–	–	–	
Hollow Shaft OHL (lbs)	3480	3480	–	–	–	–	–	–	–	
Solid Shaft OHL (lbs)	2850	2850	–	–	–	–	–	–	–	
<b>Input HP</b>	<b>29.5</b>	<b>29.5</b>	–	–	–	<b>24.9</b>	<b>16.1</b>	–	<b>13.0</b>	<b>3C175</b>
Output Torque (in•lbs)	10758	17598	–	–	–	37994	28289	–	31940	
Hollow Shaft OHL (lbs)	3480	3480	–	–	–	3480	3480	–	3480	
Solid Shaft OHL (lbs)	2850	2850	–	–	–	2850	2850	–	2850	
<b>Input HP</b>	–	–	–	–	–	–	–	–	–	<b>3D160</b>
Output Torque (in•lbs)	–	–	–	–	–	–	–	–	–	
Hollow Shaft OHL (lbs)	–	–	–	–	–	–	–	–	–	
Solid Shaft OHL (lbs)	–	–	–	–	–	–	–	–	–	
<b>Input HP</b>	–	–	–	–	–	–	–	–	–	<b>3D165</b>
Output Torque (in•lbs)	–	–	–	–	–	–	–	–	–	
Hollow Shaft OHL (lbs)	–	–	–	–	–	–	–	–	–	
Solid Shaft OHL (lbs)	–	–	–	–	–	–	–	–	–	
<b>Input HP</b>	–	–	–	–	–	–	–	–	–	<b>3D170</b>
Output Torque (in•lbs)	–	–	–	–	–	–	–	–	–	
Hollow Shaft OHL (lbs)	–	–	–	–	–	–	–	–	–	
Solid Shaft OHL (lbs)	–	–	–	–	–	–	–	–	–	
<b>Input HP</b>	–	–	–	–	–	–	–	–	–	<b>3D175</b>
Output Torque (in•lbs)	–	–	–	–	–	–	–	–	–	
Hollow Shaft OHL (lbs)	–	–	–	–	–	–	–	–	–	
Solid Shaft OHL (lbs)	–	–	–	–	–	–	–	–	–	
<b>Input HP</b>	–	–	–	–	–	–	–	–	–	<b>3E170</b>
Output Torque (in•lbs)	–	–	–	–	–	–	–	–	–	
Hollow Shaft OHL (lbs)	–	–	–	–	–	–	–	–	–	
Solid Shaft OHL (lbs)	–	–	–	–	–	–	–	–	–	
<b>Input HP</b>	–	–	–	–	–	–	–	–	–	<b>3E175</b>
Output Torque (in•lbs)	–	–	–	–	–	–	–	–	–	
Hollow Shaft OHL (lbs)	–	–	–	–	–	–	–	–	–	
Solid Shaft OHL (lbs)	–	–	–	–	–	–	–	–	–	

## 60 Hz, 1750 RPM Frame Size Selection Tables

Single Reduction  
Y2, Y4 Mounting Positions

Dimensions on pages 2.22–2.23

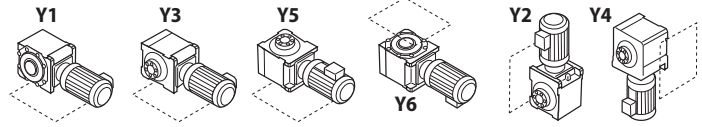
Output RPM	19.9	17.2	14.2	11.6	9.8	8.45	7.03	5.74	4.20	Frame Size
Ratio	88	102	123	151	179	207	249	305	417	
<b>Input HP</b>	-	<b>5.59</b>	-	<b>3.77</b>	<b>3.18</b>	-	<b>2.28</b>	-	-	<b>3B165</b>
Output Torque (in•lbs)	-	18844	-	18844	18853	-	18805	-	-	
Hollow Shaft OHL (lbs)	-	2070	-	2070	2070	-	2070	-	-	
Solid Shaft OHL (lbs)	-	1640	-	1640	1640	-	1640	-	-	
<b>Input HP</b>	-	-	-	-	-	-	-	-	-	<b>3C140</b>
Output Torque (in•lbs)	-	-	-	-	-	-	-	-	-	
Hollow Shaft OHL (lbs)	-	-	-	-	-	-	-	-	-	
Solid Shaft OHL (lbs)	-	-	-	-	-	-	-	-	-	
<b>Input HP</b>	<b>7.46</b>	-	<b>5.02</b>	-	-	<b>2.98</b>	-	<b>2.04</b>	-	<b>3C145</b>
Output Torque (in•lbs)	21736	-	20498	-	-	20448	-	20607	-	
Hollow Shaft OHL (lbs)	3480	-	3480	-	-	3480	-	3480	-	
Solid Shaft OHL (lbs)	2850	-	2850	-	-	2850	-	2850	-	
<b>Input HP</b>	-	-	-	-	-	-	-	-	-	<b>3C160</b>
Output Torque (in•lbs)	-	-	-	-	-	-	-	-	-	
Hollow Shaft OHL (lbs)	-	-	-	-	-	-	-	-	-	
Solid Shaft OHL (lbs)	-	-	-	-	-	-	-	-	-	
<b>Input HP</b>	<b>10.2</b>	<b>10.2</b>	<b>9.27</b>	<b>5.02</b>	<b>5.02</b>	<b>5.02</b>	<b>2.98</b>	<b>2.98</b>	-	<b>3C165</b>
Output Torque (in•lbs)	29720	34385	37852	25093	29762	34447	24579	30103	-	
Hollow Shaft OHL (lbs)	3480	3480	3480	3480	3480	3480	3480	3480	-	
Solid Shaft OHL (lbs)	2850	2850	2850	2850	2850	2850	2850	2850	-	
<b>Input HP</b>	-	-	-	-	-	-	-	-	-	<b>3C170</b>
Output Torque (in•lbs)	-	-	-	-	-	-	-	-	-	
Hollow Shaft OHL (lbs)	-	-	-	-	-	-	-	-	-	
Solid Shaft OHL (lbs)	-	-	-	-	-	-	-	-	-	
<b>Input HP</b>	<b>13.0</b>	<b>11.2</b>	-	<b>7.54</b>	<b>6.36</b>	<b>5.50</b>	<b>4.57</b>	<b>3.73</b>	-	<b>3C175</b>
Output Torque (in•lbs)	37878	37756	-	37689	37707	37740	37693	37679	-	
Hollow Shaft OHL (lbs)	3480	3480	-	3480	3480	3480	3480	3480	-	
Solid Shaft OHL (lbs)	2850	2850	-	2850	2850	2850	2850	2850	-	
<b>Input HP</b>	-	-	-	-	-	-	-	-	-	<b>3D160</b>
Output Torque (in•lbs)	-	-	-	-	-	-	-	-	-	
Hollow Shaft OHL (lbs)	-	-	-	-	-	-	-	-	-	
Solid Shaft OHL (lbs)	-	-	-	-	-	-	-	-	-	
<b>Input HP</b>	-	-	<b>10.2</b>	-	-	-	-	-	-	<b>3D165</b>
Output Torque (in•lbs)	-	-	41650	-	-	-	-	-	-	
Hollow Shaft OHL (lbs)	-	-	4810	-	-	-	-	-	-	
Solid Shaft OHL (lbs)	-	-	3930	-	-	-	-	-	-	
<b>Input HP</b>	-	-	-	-	-	-	-	-	-	<b>3D170</b>
Output Torque (in•lbs)	-	-	-	-	-	-	-	-	-	
Hollow Shaft OHL (lbs)	-	-	-	-	-	-	-	-	-	
Solid Shaft OHL (lbs)	-	-	-	-	-	-	-	-	-	
<b>Input HP</b>	<b>14.9</b>	<b>14.9</b>	-	<b>10.2</b>	<b>7.46</b>	<b>7.46</b>	<b>5.02</b>	<b>5.02</b>	-	<b>3D175</b>
Output Torque (in•lbs)	43414	50229	-	50985	44228	51190	41405	50710	-	
Hollow Shaft OHL (lbs)	4810	4810	-	4810	4810	4810	4810	4810	-	
Solid Shaft OHL (lbs)	3930	3930	-	3930	3930	3930	3930	3930	-	
<b>Input HP</b>	-	-	-	-	-	-	-	-	-	<b>3E170</b>
Output Torque (in•lbs)	-	-	-	-	-	-	-	-	-	
Hollow Shaft OHL (lbs)	-	-	-	-	-	-	-	-	-	
Solid Shaft OHL (lbs)	-	-	-	-	-	-	-	-	-	
<b>Input HP</b>	<b>14.9</b>	<b>14.9</b>	<b>10.2</b>	<b>10.2</b>	<b>7.46</b>	<b>7.46</b>	<b>5.02</b>	<b>5.02</b>	-	<b>3E175</b>
Output Torque (in•lbs)	43414	50229	41650	50985	44228	51190	41405	50710	-	
Hollow Shaft OHL (lbs)	5170	5170	5170	5170	5170	5170	5170	5170	-	
Solid Shaft OHL (lbs)	4110	4110	4110	4110	4110	4110	4110	4110	-	

Speed  
ReducersSelection  
Tables

# Frame Size Selection Tables 60 Hz, 1750 RPM

## Double Reduction Y1, Y2, Y3, Y4, Y5, Y6 Mounting Positions

Dimensions on pages 2.24–2.25

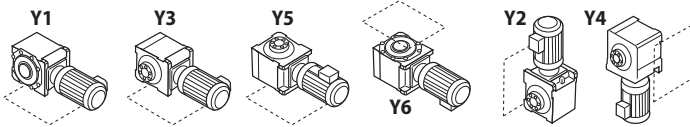


Speed Reducers  
Selection Tables

Output RPM	4.81	4.13	3.50	3.03	2.56	2.16	1.83	1.57	1.33	1.06	0.894	0.770	0.684	Frame Size
Ratio	364	424	501	578	683	809	956	1117	1320	1656	1957	2272	2559	
<b>Input HP</b>	<b>0.576</b>	<b>0.576</b>	<b>0.573</b>	<b>0.496</b>	<b>0.420</b>	<b>0.355</b>	<b>0.300</b>	<b>0.257</b>	<b>0.217</b>	<b>0.173</b>	<b>0.147</b>	<b>0.134</b>	<b>0.134</b>	<b>3A10DA</b>
Output Torque (in•lbs)	6603	7682	9028	9028	9028	9028	9028	9028	9028	9028	9028	8939	9028	
Hollow Shaft OHL (lbs)	1120	1120	1120	1120	1120	1120	1120	1120	1120	1120	1120	1120	1120	
Solid Shaft OHL (lbs)	990	990	990	990	990	990	990	990	990	990	990	990	990	
<b>Input HP</b>	-	-	<b>0.576</b>	<b>0.576</b>	<b>0.531</b>	<b>0.448</b>	<b>0.379</b>	<b>0.324</b>	<b>0.275</b>	<b>0.219</b>	<b>0.185</b>	<b>0.159</b>	<b>0.142</b>	<b>3A12DA</b>
Output Torque (in•lbs)	-	-	9116	10444	11417	11417	11417	11417	11417	11417	11417	11417	11417	
Hollow Shaft OHL (lbs)	-	-	1120	1120	1120	1120	1120	1120	1120	1120	1120	1120	1120	
Solid Shaft OHL (lbs)	-	-	990	990	990	990	990	990	990	990	990	990	990	
<b>Input HP</b>	<b>0.995</b>	<b>0.855</b>	<b>0.724</b>	<b>0.627</b>	-	-	-	-	-	-	-	-	-	<b>3A12DB</b>
Output Torque (in•lbs)	11417	11417	11417	11417	-	-	-	-	-	-	-	-	-	
Hollow Shaft OHL (lbs)	1120	1120	1120	1120	-	-	-	-	-	-	-	-	-	
Solid Shaft OHL (lbs)	990	990	990	990	-	-	-	-	-	-	-	-	-	
<b>Input HP</b>	-	-	-	-	<b>0.576</b>	<b>0.576</b>	<b>0.576</b>	<b>0.539</b>	<b>0.456</b>	<b>0.364</b>	<b>0.308</b>	<b>0.265</b>	<b>0.235</b>	<b>3B12DA</b>
Output Torque (in•lbs)	-	-	-	-	12391	14692	17347	18940	18940	18940	18940	18940	18940	
Hollow Shaft OHL (lbs)	-	-	-	-	2060	2060	2060	2060	2060	2060	2060	2060	2060	
Solid Shaft OHL (lbs)	-	-	-	-	1640	1640	1640	1640	1640	1640	1640	1640	1640	
<b>Input HP</b>	<b>1.65</b>	<b>1.40</b>	<b>1.20</b>	<b>1.04</b>	<b>0.882</b>	<b>0.744</b>	<b>0.630</b>	-	-	-	-	-	-	<b>3B12DB</b>
Output Torque (in•lbs)	18940	18763	18940	18940	18940	18940	18940	-	-	-	-	-	-	
Hollow Shaft OHL (lbs)	2060	2060	2060	2060	2060	2060	2060	-	-	-	-	-	-	
Solid Shaft OHL (lbs)	1640	1640	1640	1640	1640	1640	1640	-	-	-	-	-	-	
<b>Input HP</b>	-	-	-	-	-	-	-	<b>0.576</b>	<b>0.547</b>	<b>0.436</b>	<b>0.369</b>	<b>0.318</b>	<b>0.282</b>	<b>3B14DA</b>
Output Torque (in•lbs)	-	-	-	-	-	-	-	20268	22746	22746	22746	22746	22746	
Hollow Shaft OHL (lbs)	-	-	-	-	-	-	-	2060	2060	2060	2060	2060	2060	
Solid Shaft OHL (lbs)	-	-	-	-	-	-	-	1640	1640	1640	1640	1640	1640	
<b>Input HP</b>	<b>1.98</b>	<b>1.70</b>	<b>1.44</b>	<b>1.25</b>	<b>1.06</b>	<b>0.893</b>	<b>0.755</b>	<b>0.646</b>	-	-	-	-	-	<b>3B14DB</b>
Output Torque (in•lbs)	22746	22746	22746	22746	22746	22746	22746	22746	-	-	-	-	-	
Hollow Shaft OHL (lbs)	2060	2060	2060	2060	2060	2060	2060	2060	-	-	-	-	-	
Solid Shaft OHL (lbs)	1640	1640	1640	1640	1640	1640	1640	1640	-	-	-	-	-	

**NOTE:** Motor HP in **GRAY** is to overcome breakaway torque requirements in cold temperatures or high inertia applications. A torque limiting device is recommended to protect the unit or driven machine.

# 60 Hz, 1750 RPM Frame Size Selection Tables



## Double Reduction Y1, Y2, Y3, Y4, Y5, Y6 Mounting Positions

Dimensions on pages 2.24–2.25

Output RPM	0.595	0.499	0.401	0.338	0.270	0.242	0.197	0.164	0.144	0.113	0.0974	0.0809	0.0661	Frame Size
Ratio	2944	3511	4365	5177	6472	7228	8880	10658	12184	15530	17966	21620	26492	
<b>Input HP</b>	0.134	0.134	0.134	0.134	0.134	0.134	0.134	0.134	0.134	0.134	0.134	-	-	<b>3A10DA</b>
Output Torque (in•lbs)	9028	8939	9028	9028	9028	8939	8939	9028	8939	9028	9028	-	-	
Hollow Shaft OHL (lbs)	1120	120	1120	1120	1120	1120	1120	1120	1120	1120	1120	-	-	
Solid Shaft OHL (lbs)	990	990	990	990	990	990	990	990	990	990	-	-		
<b>Input HP</b>	0.134	0.134	0.134	0.134	0.134	0.134	0.134	0.134	0.134	0.134	0.134	-	-	<b>3A12DA</b>
Output Torque (in•lbs)	11417	11417	11417	11417	11417	11417	11417	11417	11417	11417	11417	-	-	
Hollow Shaft OHL (lbs)	1120	1120	1120	1120	1120	1120	1120	1120	1120	1120	1120	-	-	
Solid Shaft OHL (lbs)	990	990	990	990	990	990	990	990	990	990	990	-	-	
<b>Input HP</b>	-	-	-	-	-	-	-	-	-	-	-	0.134	0.134	<b>3A12DB</b>
Output Torque (in•lbs)	-	-	-	-	-	-	-	-	-	-	-	11417	11417	
Hollow Shaft OHL (lbs)	-	-	-	-	-	-	-	-	-	-	-	1120	1120	
Solid Shaft OHL (lbs)	-	-	-	-	-	-	-	-	-	-	-	990	990	
<b>Input HP</b>	0.205	0.171	0.138	0.134	0.134	0.134	0.134	0.134	0.134	0.134	0.134	-	-	<b>3B12DA</b>
Output Torque (in•lbs)	18940	18940	18940	18940	18940	18940	18940	18940	18940	18940	18940	-	-	
Hollow Shaft OHL (lbs)	2060	2060	2060	2060	2060	2060	2060	2060	2060	2060	2060	-	-	
Solid Shaft OHL (lbs)	1640	1640	1640	1640	1640	1640	1640	1640	1640	1640	1640	-	-	
<b>Input HP</b>	-	-	-	-	-	-	-	-	-	-	-	0.138	0.134	<b>3B12DB</b>
Output Torque (in•lbs)	-	-	-	-	-	-	-	-	-	-	-	18940	18940	
Hollow Shaft OHL (lbs)	-	-	-	-	-	-	-	-	-	-	-	2060	2060	
Solid Shaft OHL (lbs)	-	-	-	-	-	-	-	-	-	-	-	1640	1640	
<b>Input HP</b>	0.268	0.268	0.268	0.268	0.268	0.268	0.268	0.268	0.268	0.268	0.268	-	-	<b>3B14DA</b>
Output Torque (in•lbs)	22746	22746	22746	22746	22746	22746	22746	22746	22746	22746	22746	-	-	
Hollow Shaft OHL (lbs)	2060	2060	2060	2060	2060	2060	2060	2060	2060	2060	2060	-	-	
Solid Shaft OHL (lbs)	1640	1640	1640	1640	1640	1640	1640	1640	1640	1640	1640	-	-	
<b>Input HP</b>	-	-	-	-	-	-	-	-	-	-	-	0.268	0.268	<b>3B14DB</b>
Output Torque (in•lbs)	-	-	-	-	-	-	-	-	-	-	-	22746	22746	
Hollow Shaft OHL (lbs)	-	-	-	-	-	-	-	-	-	-	-	2060	2060	
Solid Shaft OHL (lbs)	-	-	-	-	-	-	-	-	-	-	-	1640	1640	

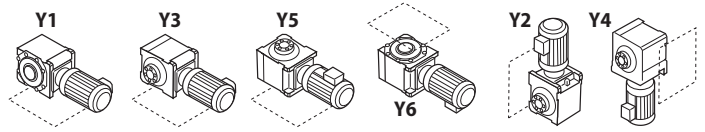
Speed Reducers  
Selection Tables

**NOTE:** Motor HP in **GRAY** is to overcome breakaway torque requirements in cold temperatures or high inertia applications. A torque limiting device is recommended to protect the unit or driven machine.

# Frame Size Selection Tables 60 Hz, 1750 RPM

## Double Reduction Y1, Y2, Y3, Y4, Y5, Y6 Mounting Positions

Dimensions on pages 2.24–2.25



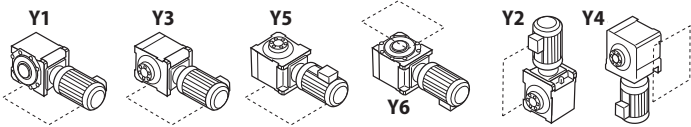
Speed Reducers  
Selection Tables

Output RPM	4.81	4.13	3.50	3.03	2.56	2.16	1.83	1.57	1.33	1.06	0.894	0.770	0.684	Frame Size
Ratio	364	424	501	578	683	809	956	1117	1320	1656	1957	2272	2559	
<b>Input HP</b>	-	-	-	-	-	-	-	-	<b>0.576</b>	<b>0.576</b>	<b>0.576</b>	<b>0.576</b>	<b>0.512</b>	<b>3C14DA</b>
Output Torque (in•lbs)	-	-	-	-	-	-	-	-	23985	30004	35491	41244	41244	
Hollow Shaft OHL (lbs)	-	-	-	-	-	-	-	-	3480	3480	3480	3480	3480	
Solid Shaft OHL (lbs)	-	-	-	-	-	-	-	-	2850	2850	2850	2850	2850	
<b>Input HP</b>	<b>2.14</b>	<b>2.14</b>	<b>2.14</b>	<b>2.14</b>	<b>1.90</b>	<b>1.58</b>	<b>1.34</b>	<b>1.17</b>	<b>0.992</b>	<b>0.791</b>	<b>0.669</b>	-	-	<b>3C14DB</b>
Output Torque (in•lbs)	24605	28588	33810	39032	40890	40271	40271	41244	41244	41244	41244	-	-	
Hollow Shaft OHL (lbs)	3480	3480	3480	3480	3480	3480	3480	3480	3480	3480	3480	-	-	
Solid Shaft OHL (lbs)	2850	2850	2850	2850	2850	2850	2850	2850	2850	2850	2850	-	-	
<b>Input HP</b>	<b>3.60</b>	<b>2.92</b>	<b>2.62</b>	<b>2.25</b>	-	-	-	-	-	-	-	-	-	<b>3C14DC</b>
Output Torque (in•lbs)	41244	38943	41244	40890	-	-	-	-	-	-	-	-	-	
Hollow Shaft OHL (lbs)	3480	3480	3480	3480	-	-	-	-	-	-	-	-	-	
Solid Shaft OHL (lbs)	2850	2850	2850	2850	-	-	-	-	-	-	-	-	-	
<b>Input HP</b>	-	-	-	-	<b>2.12</b>	<b>1.79</b>	<b>1.51</b>	<b>1.29</b>	<b>1.09</b>	<b>0.872</b>	<b>0.738</b>	<b>0.635</b>	<b>0.564</b>	<b>3C16DA</b>
Output Torque (in•lbs)	-	-	-	-	45493	45493	45493	45493	45493	45493	45493	45493	45493	
Hollow Shaft OHL (lbs)	-	-	-	-	3480	3480	3480	3480	3480	3480	3480	3480	3480	
Solid Shaft OHL (lbs)	-	-	-	-	2850	2850	2850	2850	2850	2850	2850	2850	2850	
<b>Input HP</b>	<b>3.97</b>	<b>3.41</b>	<b>2.88</b>	<b>2.50</b>	-	-	-	-	-	-	-	-	-	<b>3C16DB</b>
Output Torque (in•lbs)	45493	45493	45493	45493	-	-	-	-	-	-	-	-	-	
Hollow Shaft OHL (lbs)	3480	3480	3480	3480	-	-	-	-	-	-	-	-	-	
Solid Shaft OHL (lbs)	2850	2850	2850	2850	-	-	-	-	-	-	-	-	-	
<b>Input HP</b>	-	-	-	-	<b>2.14</b>	<b>2.14</b>	<b>2.10</b>	<b>1.80</b>	<b>1.52</b>	<b>1.21</b>	<b>1.03</b>	<b>0.883</b>	<b>0.784</b>	<b>3D16DA</b>
Output Torque (in•lbs)	-	-	-	-	46112	54609	63283	63283	63283	63283	63283	63283	63283	
Hollow Shaft OHL (lbs)	-	-	-	-	4810	4810	4810	4810	4810	4810	4810	4810	4810	
Solid Shaft OHL (lbs)	-	-	-	-	3930	3930	3930	3930	3930	3930	3930	3930	3930	
<b>Input HP</b>	<b>4.50</b>	<b>4.50</b>	<b>4.01</b>	<b>3.48</b>	<b>2.94</b>	<b>2.48</b>	-	-	-	-	-	-	-	<b>3D16DB</b>
Output Torque (in•lbs)	51600	60096	63283	63283	63283	63283	-	-	-	-	-	-	-	
Hollow Shaft OHL (lbs)	4810	4810	4810	4810	4810	4810	-	-	-	-	-	-	-	
Solid Shaft OHL (lbs)	3930	3930	3930	3930	3930	3930	-	-	-	-	-	-	-	

**NOTE:** Motor HP in **GRAY** is to overcome breakaway torque requirements in cold temperatures or high inertia applications. A torque limiting device is recommended to protect the unit or driven machine.



## 60 Hz, 1750 RPM Frame Size Selection Tables

Double Reduction  
Y1, Y2, Y3, Y4, Y5, Y6 Mounting Positions

Dimensions on pages 2.24–2.25

Output RPM	0.595	0.499	0.401	0.338	0.270	0.242	0.197	0.164	0.144	0.113	0.0974	0.0809	0.0661	Frame Size
Ratio	2944	3511	4365	5177	6472	7228	8880	10658	12184	15530	17966	21620	26492	
<b>Input HP</b>	<b>0.405</b>	<b>0.373</b>	<b>0.300</b>	<b>0.268</b>	<b>0.268</b>	<b>0.268</b>	<b>0.268</b>	<b>0.268</b>	<b>0.268</b>	<b>0.268</b>	<b>0.268</b>	-	-	<b>3C14DA</b>
Output Torque (in•lbs)	37615	41244	41244	37615	41244	41244	41244	37615	41244	37615	37615	-	-	
Hollow Shaft OHL (lbs)	3480	3480	3480	3480	3480	3480	3480	3480	3480	3480	3480	-	-	
Solid Shaft OHL (lbs)	2850	2850	2850	2850	2850	2850	2850	2850	2850	2850	2850	-	-	
<b>Input HP</b>	<b>0.445</b>	<b>0.445</b>	-	-	-	-	-	-	-	-	-	<b>0.268</b>	<b>0.268</b>	<b>3C14DB</b>
Output Torque (in•lbs)	41244	41244	-	-	-	-	-	-	-	-	-	37615	37615	
Hollow Shaft OHL (lbs)	3480	3480	-	-	-	-	-	-	-	-	-	3480	3480	
Solid Shaft OHL (lbs)	2850	2850	-	-	-	-	-	-	-	-	-	2850	2850	
<b>Input HP</b>	-	-	-	-	-	-	-	-	-	-	-	-	-	<b>3C14DC</b>
Output Torque (in•lbs)	-	-	-	-	-	-	-	-	-	-	-	-	-	
Hollow Shaft OHL (lbs)	-	-	-	-	-	-	-	-	-	-	-	-	-	
Solid Shaft OHL (lbs)	-	-	-	-	-	-	-	-	-	-	-	-	-	
<b>Input HP</b>	<b>0.536</b>	<b>0.536</b>	<b>0.536</b>	<b>0.536</b>	<b>0.536</b>	<b>0.536</b>	<b>0.268</b>	<b>0.268</b>	<b>0.268</b>	<b>0.268</b>	<b>0.268</b>	<b>0.268</b>	<b>0.268</b>	<b>3C16DA</b>
Output Torque (in•lbs)	45493	45493	45493	45493	45493	45493	45493	45493	45493	45493	45493	45493	45493	
Hollow Shaft OHL (lbs)	3480	3480	3480	3480	3480	3480	3480	3480	3480	3480	3480	3480	3480	
Solid Shaft OHL (lbs)	2850	2850	2850	2850	2850	2850	2850	2850	2850	2850	2850	2850	2850	
<b>Input HP</b>	-	-	-	-	-	-	-	<b>0.268</b>	-	-	-	-	-	<b>3C16DB</b>
Output Torque (in•lbs)	-	-	-	-	-	-	-	45493	-	-	-	-	-	
Hollow Shaft OHL (lbs)	-	-	-	-	-	-	-	3480	-	-	-	-	-	
Solid Shaft OHL (lbs)	-	-	-	-	-	-	-	2850	-	-	-	-	-	
<b>Input HP</b>	<b>0.682</b>	<b>0.572</b>	<b>0.536</b>	<b>0.536</b>	<b>0.536</b>	<b>0.536</b>	<b>0.268</b>	<b>0.268</b>	<b>0.268</b>	<b>0.268</b>	<b>0.268</b>	<b>0.268</b>	<b>0.268</b>	<b>3D16DA</b>
Output Torque (in•lbs)	63283	63283	63283	61778	63283	63283	63283	61778	63283	61778	61778	61778	61778	
Hollow Shaft OHL (lbs)	4810	4810	4810	4810	4810	4810	4810	4810	4810	4810	4810	4810	4810	
Solid Shaft OHL (lbs)	3930	3930	3930	3930	3930	3930	3930	3930	3930	3930	3930	3930	3930	
<b>Input HP</b>	-	-	-	-	-	-	-	-	-	-	-	-	-	<b>3D16DB</b>
Output Torque (in•lbs)	-	-	-	-	-	-	-	-	-	-	-	-	-	
Hollow Shaft OHL (lbs)	-	-	-	-	-	-	-	-	-	-	-	-	-	
Solid Shaft OHL (lbs)	-	-	-	-	-	-	-	-	-	-	-	-	-	

Speed Reducers

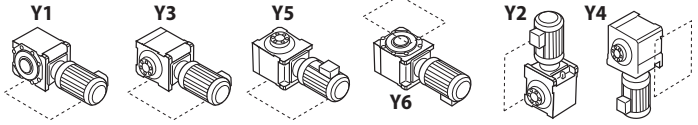
Selection Tables

**NOTE:** Motor HP in **GRAY** is to overcome breakaway torque requirements in cold temperatures or high inertia applications. A torque limiting device is recommended to protect the unit or driven machine.

# Frame Size Selection Tables 60 Hz, 1750 RPM

## Double Reduction Y1, Y2, Y3, Y4, Y5, Y6 Mounting Positions

Dimensions on pages 2.24–2.25

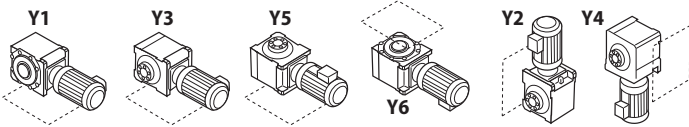


Output RPM	4.81	4.13	3.50	3.03	2.56	2.16	1.83	1.57	1.33	1.06	0.894	0.770	0.684	Frame Size
Ratio	364	424	501	578	683	809	956	1117	1320	1656	1957	2272	2559	
<b>Input HP</b>	<b>5.51</b>	<b>4.74</b>	-	-	-	-	-	-	-	-	-	-	-	<b>3D16DC</b>
Output Torque (in•lbs)	63283	63283	-	-	-	-	-	-	-	-	-	-	-	
Hollow Shaft OHL (lbs)	4810	4810	-	-	-	-	-	-	-	-	-	-	-	
Solid Shaft OHL (lbs)	3930	3930	-	-	-	-	-	-	-	-	-	-	-	
<b>Input HP</b>	-	-	-	-	-	-	<b>2.14</b>	<b>2.14</b>	<b>1.86</b>	<b>1.48</b>	<b>1.25</b>	<b>1.08</b>	<b>0.957</b>	<b>3D17DA</b>
Output Torque (in•lbs)	-	-	-	-	-	-	64610	75496	77178	77178	77178	77178	77178	
Hollow Shaft OHL (lbs)	-	-	-	-	-	-	4810	4810	4810	4810	4810	4810	4810	
Solid Shaft OHL (lbs)	-	-	-	-	-	-	3930	3930	3930	3930	3930	3930	3930	
<b>Input HP</b>	-	-	<b>4.50</b>	<b>4.24</b>	<b>3.59</b>	<b>3.03</b>	<b>2.56</b>	<b>2.19</b>	-	-	-	-	-	<b>3D17DB</b>
Output Torque (in•lbs)	-	-	70983	77178	77178	77178	77178	77178	-	-	-	-	-	
Hollow Shaft OHL (lbs)	-	-	4810	4810	4810	4810	4810	4810	-	-	-	-	-	
Solid Shaft OHL (lbs)	-	-	3930	3930	3930	3930	3930	3930	-	-	-	-	-	
<b>Input HP</b>	<b>6.73</b>	<b>5.78</b>	<b>4.90</b>	-	-	-	-	-	-	-	-	-	-	<b>3D17DC</b>
Output Torque (in•lbs)	77178	77178	77178	-	-	-	-	-	-	-	-	-	-	
Hollow Shaft OHL (lbs)	4810	4810	4810	-	-	-	-	-	-	-	-	-	-	
Solid Shaft OHL (lbs)	3930	3930	3930	-	-	-	-	-	-	-	-	-	-	
<b>Input HP</b>	-	-	-	-	-	-	-	-	<b>2.14</b>	<b>1.82</b>	<b>1.54</b>	<b>1.33</b>	<b>1.18</b>	<b>3E17DA</b>
Output Torque (in•lbs)	-	-	-	-	-	-	-	-	89392	94702	94702	94702	94702	
Hollow Shaft OHL (lbs)	-	-	-	-	-	-	-	-	5170	5170	5170	5170	5170	
Solid Shaft OHL (lbs)	-	-	-	-	-	-	-	-	4110	4110	4110	4110	4110	
<b>Input HP</b>	-	-	-	<b>4.50</b>	<b>4.41</b>	<b>3.72</b>	<b>3.15</b>	<b>2.70</b>	<b>2.28</b>	-	-	-	-	<b>3E17DB</b>
Output Torque (in•lbs)	-	-	-	81957	94702	94702	94702	94702	94702	-	-	-	-	
Hollow Shaft OHL (lbs)	-	-	-	5170	5170	5170	5170	5170	5170	-	-	-	-	
Solid Shaft OHL (lbs)	-	-	-	4110	4110	4110	4110	4110	4110	-	-	-	-	
<b>Input HP</b>	<b>8.27</b>	<b>7.11</b>	<b>6.01</b>	<b>5.21</b>	-	-	-	-	-	-	-	-	-	<b>3E17DC</b>
Output Torque (in•lbs)	94702	94702	94702	94702	-	-	-	-	-	-	-	-	-	
Hollow Shaft OHL (lbs)	5170	5170	5170	5170	-	-	-	-	-	-	-	-	-	
Solid Shaft OHL (lbs)	4110	4110	4110	4110	-	-	-	-	-	-	-	-	-	

**NOTE:** Motor HP in **GRAY** is to overcome breakaway torque requirements in cold temperatures or high inertia applications. A torque limiting device is recommended to protect the unit or driven machine.

Speed Reducers  
Selection Tables

## 60 Hz, 1750 RPM Frame Size Selection Tables

Double Reduction  
Y1, Y2, Y3, Y4, Y5, Y6 Mounting Positions

Dimensions on pages 2.24–2.25

Output RPM	0.595	0.499	0.401	0.338	0.270	0.242	0.197	0.164	0.144	0.113	0.0974	0.0809	0.0661	Frame Size
Ratio	2944	3511	4365	5177	6472	7228	8880	10658	12184	15530	17966	21620	26492	
<b>Input HP</b>	-	-	-	-	-	-	-	-	-	-	-	-	-	<b>3D16DC</b>
Output Torque (in•lbs)	-	-	-	-	-	-	-	-	-	-	-	-	-	
Hollow Shaft OHL (lbs)	-	-	-	-	-	-	-	-	-	-	-	-	-	
Solid Shaft OHL (lbs)	-	-	-	-	-	-	-	-	-	-	-	-	-	
<b>Input HP</b>	<b>0.832</b>	<b>0.698</b>	<b>0.561</b>	-	-	-	-	<b>0.536</b>	<b>0.268</b>	<b>0.268</b>	<b>0.268</b>	<b>0.268</b>	<b>0.268</b>	<b>3D17DA</b>
Output Torque (in•lbs)	77178	77178	77178	-	-	-	-	77178	77178	77178	77178	77178	77178	
Hollow Shaft OHL (lbs)	4810	4810	4810	-	-	-	-	4810	4810	4810	4810	4810	4810	
Solid Shaft OHL (lbs)	3930	3930	3930	-	-	-	-	3930	3930	3930	3930	3930	3930	
<b>Input HP</b>	-	-	-	-	-	-	-	-	-	-	-	-	-	<b>3D17DB</b>
Output Torque (in•lbs)	-	-	-	-	-	-	-	-	-	-	-	-	-	
Hollow Shaft OHL (lbs)	-	-	-	-	-	-	-	-	-	-	-	-	-	
Solid Shaft OHL (lbs)	-	-	-	-	-	-	-	-	-	-	-	-	-	
<b>Input HP</b>	-	-	-	-	-	-	-	-	-	-	-	-	-	<b>3D17DC</b>
Output Torque (in•lbs)	-	-	-	-	-	-	-	-	-	-	-	-	-	
Hollow Shaft OHL (lbs)	-	-	-	-	-	-	-	-	-	-	-	-	-	
Solid Shaft OHL (lbs)	-	-	-	-	-	-	-	-	-	-	-	-	-	
<b>Input HP</b>	<b>1.02</b>	<b>0.857</b>	<b>0.690</b>	<b>0.582</b>	<b>0.536</b>	<b>0.536</b>	<b>0.536</b>	<b>0.536</b>	<b>0.268</b>	<b>0.268</b>	<b>0.268</b>	<b>0.268</b>	<b>0.268</b>	<b>3E17DA</b>
Output Torque (in•lbs)	94702	94702	94702	94702	94702	94702	94702	94702	94702	94702	94702	94702	94702	
Hollow Shaft OHL (lbs)	5170	5170	5170	5170	5170	5170	5170	5170	5170	5170	5170	5170	5170	
Solid Shaft OHL (lbs)	4110	4110	4110	4110	4110	4110	4110	4110	4110	4110	4110	4110	4110	
<b>Input HP</b>	-	-	-	-	-	-	-	-	-	-	-	-	-	<b>3E17DB</b>
Output Torque (in•lbs)	-	-	-	-	-	-	-	-	-	-	-	-	-	
Hollow Shaft OHL (lbs)	-	-	-	-	-	-	-	-	-	-	-	-	-	
Solid Shaft OHL (lbs)	-	-	-	-	-	-	-	-	-	-	-	-	-	
<b>Input HP</b>	-	-	-	-	-	-	-	-	-	-	-	-	-	<b>3E17DC</b>
Output Torque (in•lbs)	-	-	-	-	-	-	-	-	-	-	-	-	-	
Hollow Shaft OHL (lbs)	-	-	-	-	-	-	-	-	-	-	-	-	-	
Solid Shaft OHL (lbs)	-	-	-	-	-	-	-	-	-	-	-	-	-	

Speed Reducers

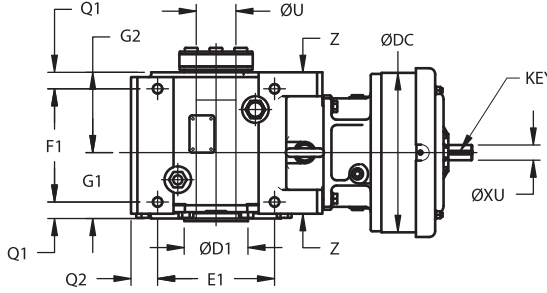
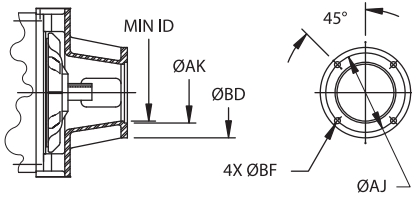
Selection Tables

**NOTE:** Motor HP in **GRAY** is to overcome breakaway torque requirements in cold temperatures or high inertia applications. A torque limiting device is recommended to protect the unit or driven machine.

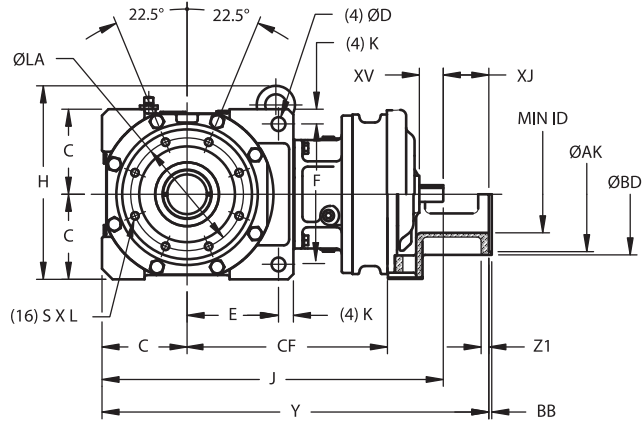
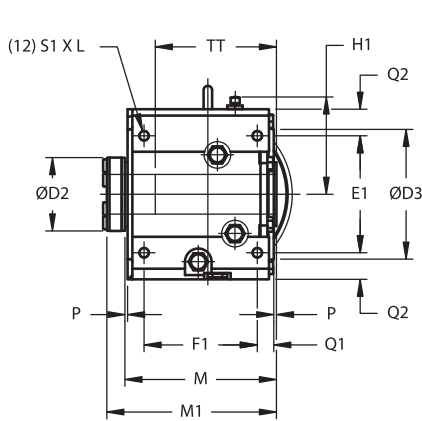
# Dimensions

## Single Reduction LHY(J)-3A100Y~3E175Y

42C~145TC



Min. Engagement	
FRAME SIZE	TT
3A	7.79
3B	9.33
3C	10.16
3D	11.82
3E	13.94



All dimensions are in inches.

Model	C	E	F	K	Z	ØD	E1	F1	Q1	Q2	S1 x L	M
3A100, 3A105 3A110, 3A115 3A120, 3A125 3A140, 3A145	4.33	4.49	7.24	0.71	1.38	0.71	5.91	6.30	0.91	1.38	M12x0.79	8.50
3B120, 3B125 3B140, 3B145 3B160, 3B165	5.12	5.59	8.43	0.91	1.58	0.87	7.48	7.68	1.06	1.38	M16x1.02	10.20
3C140, 3C145 3C160, 3C165 3C170, 3C175	6.30	6.77	10.39	1.10	1.77	1.02	8.66	8.39	1.22	1.97	M20x1.30	11.22
3D160, 3D165 3D170, 3D175	7.48	7.60	12.21	1.38	2.17	1.30	9.84	10.00	1.42	2.56	M24x1.57	13.39
3E170, 3E175	8.46	9.06	14.17	1.38	2.17	1.30	11.81	11.14	1.50	2.56	M24x1.57	14.69

Model	P	G1	G2	H	H1	ØLA	ØD3	S x L	M1	ØD1	ØD2	ØU	
												Std & Max	Min
3A100, 3A105 3A110, 3A115 3A120, 3A125 3A140, 3A145	0.20	3.78	4.33	10.87	5.16	6.10	6.89	M10x0.67	9.84	3.35	4.09	2-3/16	1-11/16
3B120, 3B125 3B140, 3B145 3B160, 3B165	0.20	4.80	5.00	12.13	5.94	6.89	7.83	M12x0.79	11.54	3.94	4.49	2-7/16	1-15/16
3C140, 3C145 3C160, 3C165 3C170, 3C175	0.20	4.88	5.94	14.33	7.20	8.35	9.61	M16x1.02	12.83	4.72	5.43	2-15/16	2-3/16
3D160, 3D165 3D170, 3D175	0.28	5.83	7.01	16.69	8.39	10.04	11.61	M20x1.30	15.00	5.51	5.98	3-7/16	2-7/16
3E170, 3E175	0.28	6.14	7.99	19.61	9.37	11.02	12.60	M20x1.38	16.30	6.30	6.69	3-15/16	2-15/16

Dimensions shown are for reference only and are subject to change without notice, unless certified.  
Certified prints are available after receipt of an order; consult factory.

## Single Reduction LHY(J)-3A100~3E175 Dimensions

With C-Face Adapter						
Model	NEMA C-Face	Y	Z1	Min. ID	XJ	Wt (lb)
3A100, 3A105	48C	17.87	0.47	2.44	2.16	111
	56C-145TC	18.33	0.47	4.21	2.63	113
	182TC-184TC	19.16	0.47	5.43	3.45	117
3A110, 3A115	56C	18.6	0.47	3.93	2.62	126
	143TC-145TC	18.6	0.47	3.93	2.62	126
	182TC-184TC	19.4	0.47	3.93	3.44	131
3A120, 3A125	143TC-145TC	19.40	0.47	4.21	2.63	133
	182TC-184TC	20.14	0.47	5.43	3.37	137
	213TC-215TC	21.14	1.47	5.43	4.37	147
3A140, 3A145	182TC-184TC	21.33	0.47	5.43	3.37	155
	213TC-215TC	21.95	1.10	5.43	4.00	161
	254TC-256TC	22.88	0.57	5.08	4.93	163
3B120, 3B125	56C-145TC	21.64	0.47	4.21	2.63	197
	182TC-184TC	22.39	0.47	5.43	3.37	201
	213TC-215TC	23.39	1.47	5.43	4.37	211
3B140, 3B145	143TC-145TC	22.63	0.47	4.21	2.63	217
	182TC-184TC	23.37	0.47	5.43	3.37	221
	213TC-215TC	24.00	1.10	5.43	4.00	227
	254TC-256TC	24.93	0.57	5.08	4.93	230
3B160, 3B165	182TC-184TC	25.46	0.57	5.71	3.37	304
	213TC-215TC	26.09	1.20	5.71	4.00	310
	254TC-256TC	26.84	0.57	5.71	4.75	306
	284TC-286TC	27.52	0.57	7.09	5.44	300
3C140, 3C145	324TC-326TC	28.59	0.57	7.87	6.50	311
	143TC-145TC	26.13	0.47	4.21	2.63	321
	182TC-184TC	26.88	0.47	5.43	3.37	325
	213TC-215TC	27.50	1.10	5.43	4.00	331
3C160, 3C165	254TC-256TC	28.43	0.57	5.08	4.93	333
	143TC-145TC	27.90	0.47	4.21	2.63	401
	182TC-184TC	28.65	0.57	5.71	3.37	405
	213TC-215TC	29.28	1.20	5.71	4.00	412
	254TC-256TC	30.03	0.57	5.71	4.75	408
3C170, 3C175	284TC-286TC	30.71	0.57	7.09	5.44	402
	324TC-326TC	31.78	0.57	7.87	6.50	412
	182TC-184TC	30.07	0.57	5.71	3.38	448
	213TC-215TC	30.70	1.20	5.71	4.00	454
3D160, 3D165	254TC-256TC	31.44	0.57	5.71	4.75	450
	284TC-286TC	32.13	0.57	7.87	5.44	461
	324TC-326TC	32.70	0.57	7.87	6.00	456
	143TC-145TC	31.92	0.47	4.21	2.63	549
3D170, 3D175	182TC-184TC	32.67	0.57	5.71	3.37	553
	213TC-215TC	33.29	1.20	5.71	4.00	559
	254TC-256TC	34.04	0.57	5.71	4.75	556
	284TC-286TC	34.73	0.57	7.09	5.44	549
	324TC-326TC	35.79	0.57	7.87	6.50	560
3E170, 3E175	182TC-184TC	33.22	0.57	5.71	3.38	587
	213TC-215TC	33.85	1.20	5.71	4.00	593
	254TC-256TC	34.59	0.57	5.71	4.75	589
	284TC-286TC	35.28	0.57	7.87	5.44	600
3E170, 3E175	324TC-326TC	35.85	0.57	7.87	6.00	594
	182TC-184TC	35.19	0.57	5.71	3.38	750
	213TC-215TC	35.81	1.20	5.71	4.00	756
	254TC-256TC	36.56	0.57	5.71	4.75	752
3E170, 3E175	284TC-286TC	37.25	0.57	7.87	5.44	763
	324TC-326TC	37.81	0.57	7.87	6.00	758

Free Shaft Input							
Model	ØXU	ØXV	Key	CF	ØDC	J	Wt (lb)
3A100, 3A105	0.625	0.98	3/16x3/16x0.75	9.33	5.91	15.71	106
3A110, 3A115	0.625	0.98	3/16x3/16x0.75	9.76	6.38	15.98	119
3A120, 3A125	0.750	1.38	3/16x3/16x1.02	9.57	8.03	16.77	123
3A140, 3A145	0.875	1.57	3/16x3/16x1.38	10.43	9.06	17.95	139
3B120, 3B125	0.750	1.38	3/16x3/16x1.02	11.02	8.03	19.02	187
3B140, 3B145	0.875	1.57	3/16x3/16x1.38	11.69	9.06	20.00	205
3B160, 3B165	1.125	1.77	1/4x1/4x1.77	12.83	11.81	22.09	258
3C140, 3C145	0.875	1.57	3/16x3/16x1.38	14.02	9.06	23.50	309
3C160, 3C165	1.125	1.77	1/4x1/4x1.77	14.84	11.81	25.28	359
3C170, 3C175	1.375	2.17	5/16x5/16x2.16	15.47	13.39	26.69	410
3D160, 3D165	1.125	1.77	1/4x1/4x1.77	17.68	11.81	29.29	507
3D170, 3D175	1.375	2.17	5/16x5/16x2.16	17.44	13.39	29.84	549
3E170, 3E175	1.375	2.17	5/16x5/16x2.16	18.43	13.39	31.81	712

NEMA C-Face Adapter	ØAJ	ØAK	ØBD	BB	ØBF
42C-48C	3.75	3.00	4.33	-	0.28
56C-145TC	5.87	4.50	6.69	-	0.43
182TC-256TC	7.25	8.50	8.98	0.22	0.55
284TC-286TC	9.00	10.50	11.10	0.22	0.55
324TC-326TC	11.00	12.50	14.17	0.22	0.71

All dimensions are in inches.

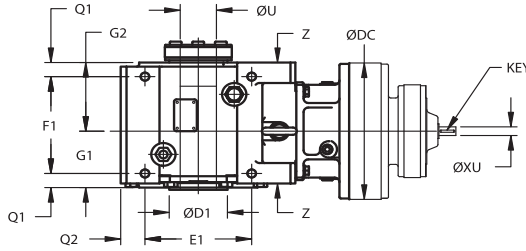
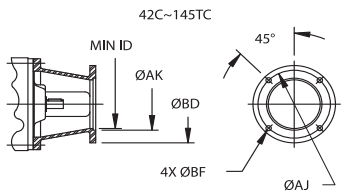
Dimensions shown are for reference only and are subject to change without notice, unless certified. Certified prints are available after receipt of an order; consult factory.

Speed Reducers

Dimensions

# Dimensions

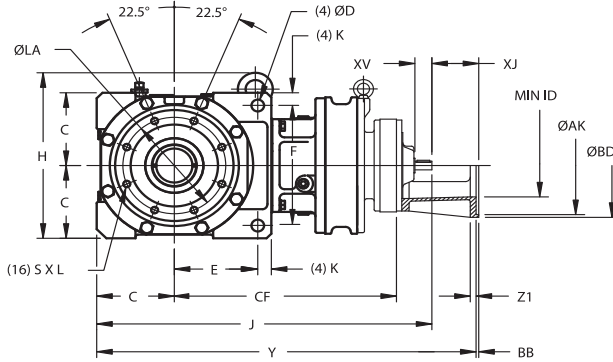
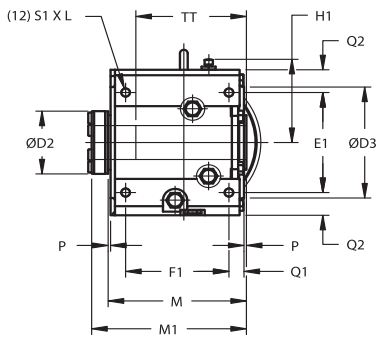
## Double Reduction LHY(J)-3A10DAY~3E17DCY



Min. Engagement	
FRAME SIZE	TT
3A	7.79
3B	9.33
3C	10.16
3D	11.82
3E	13.94

Dimensions shown are for reference only and are subject to change without notice, unless certified.

Certified prints are available after receipt of an order; consult factory.



All dimensions are in inches.

Model	C	E	F	K	Z	ØD	E1	F1	Q1	Q2	S1 x L	M
3A10DA 3A12DA 3A12DB	4.33	4.49	7.24	0.71	1.38	0.71	5.91	6.30	0.91	1.38	M12x0.79	8.50
3B12DA 3B12DB 3B14DA 3B14DB	5.12	5.59	8.43	0.91	1.58	0.87	7.48	7.68	1.06	1.38	M16x1.02	10.20
3C14DA 3C14DB 3C14DC 3C16DA 3C16DB	6.30	6.77	10.39	1.10	1.77	1.02	8.66	8.39	1.22	1.97	M20x1.30	11.22
3D16DA 3D16DB 3D16DC 3D17DA 3D17DB 3D17DC	7.48	7.60	12.21	1.38	2.17	1.30	9.84	10.00	1.42	2.56	M24x1.57	13.39
3E17DA 3E17DB 3E17DC	8.46	9.06	14.17	1.38	2.17	1.30	11.81	11.14	1.50	2.56	M24x1.57	14.69

Model	P	G1	G2	H	H1	ØLA	ØD3	S x L	M1	ØD1	ØD2	ØU	
												Std & Max	Min
3A10DA 3A12DA 3A12DB	0.20	3.78	4.33	10.87	5.16	6.10	6.89	M10x0.67	9.84	3.35	4.09	2-3/16	1-11/16
3B12DA 3B12DB 3B14DA 3B14DB	0.20	4.80	5.00	12.13	5.94	6.89	7.83	M12x0.79	11.54	3.94	4.49	2-7/16	1-15/16
3C14DA 3C14DB 3C14DC 3C16DA 3C16DB	0.20	4.88	5.94	14.33	7.20	8.35	9.61	M16x1.02	12.83	4.72	5.43	2-15/16	2-3/16
3D16DA 3D16DB 3D16DC 3D17DA 3D17DB 3D17DC	0.28	5.83	7.01	16.69	8.39	10.04	11.61	M20x1.30	15.00	5.51	5.98	3-7/16	2-7/16
3E17DA 3E17DB 3E17DC	0.28	6.14	7.99	19.61	9.37	11.02	12.60	M20x1.38	16.30	6.30	6.69	3-15/16	2-15/16

## Double Reduction LHY(J)-3C10DAY~3E17DCY Dimensions

All dimensions are in inches.

With C-Face Adapter						
Model	NEMA C-Face	Y	Z1	Min. ID	XJ	Wt (lb)
3A10DA	42C	19.42	0.47	2.44	1.78	113
	48C	19.80	0.47	2.44	2.16	113
	56C	20.20	0.47	3.15	2.56	116
3A12DA	42C	19.89	0.47	2.44	1.78	131
	48C	20.27	0.47	2.44	2.16	131
	56C	20.67	0.47	3.15	2.56	133
3A12DB	48C	21.02	0.47	2.44	2.16	139
	56C-145TC	21.48	0.47	4.21	2.63	142
3B12DA	42C	22.13	0.47	2.44	1.78	195
	48C	22.51	0.47	2.44	2.16	195
	56C	22.91	0.47	3.15	2.56	197
3B12DB	48C	23.26	0.47	2.44	2.16	203
	56C-145TC	23.73	0.47	4.21	2.63	206
3B14DA	48C	23.18	0.47	2.44	2.16	202
	56C	23.58	0.47	3.15	2.56	204
3B14DB	48C	23.81	0.47	2.44	2.16	212
	56C-145TC	24.28	0.47	4.21	2.63	215
3C14DA	48C	26.69	0.47	2.44	2.16	305
	56C	27.09	0.47	3.15	2.56	308
3C14DB	48C	27.31	0.47	2.44	2.16	316
	56C-145TC	27.78	0.47	4.21	2.63	318
3C14DC	143TC-145TC	28.02	0.47	4.21	2.63	320
	182TC-184TC	28.84	0.47	5.43	3.45	324
3C16DA	56C-145TC	28.69	0.47	4.21	2.63	369
	56C-145TC	28.92	0.47	4.21	2.63	374
3C16DB	56C-145TC	28.92	0.47	4.21	2.63	374
	182TC-184TC	29.74	0.47	5.43	3.45	380
3D16DA	48C	32.24	0.47	2.44	2.16	514
	56C-145TC	32.70	0.47	4.21	2.63	517
3D16DB	143TC-145TC	32.94	0.47	4.21	2.63	521
	182TC-184TC	33.76	0.47	5.43	3.45	525
3D16DC	182TC-184TC	34.16	0.47	5.43	3.37	542
	213TC-215TC	35.16	1.47	5.43	4.37	544
3D17DA	56C-145TC	32.51	0.47	4.21	2.63	548
3D17DB	143TC-145TC	32.74	0.47	4.21	2.63	552
	182TC-184TC	33.57	0.47	5.43	3.45	556
3D17DC	182TC-184TC	34.47	0.47	5.43	3.37	569
	213TC-215TC	35.47	1.47	5.43	4.37	579
3E17DA	48C	34.01	0.47	2.44	2.16	708
	56C-145TC	34.48	0.47	4.21	2.63	711
3E17DB	143TC-145TC	34.71	0.47	4.21	2.63	715
	182TC-184TC	35.54	0.47	5.43	3.45	719
3E17DC	182TC-184TC	36.44	0.47	5.43	3.37	732
	213TC-215TC	37.44	1.47	5.43	4.37	743

Free Shaft Input							
Model	ØXU	ØXV	Key	CF	ØDC	J	Wt (lb)
3A10DA	0.500	0.98	1/8x1/8x0.71	11.22	5.91	17.64	110
3A12DA	0.500	0.98	1/8x1/8x0.71	11.69	8.03	18.11	128
3A12DB	0.625	0.98	3/16x3/16x0.75	12.17	8.03	18.86	135
3B12DA	0.500	0.98	1/8x1/8x0.71	13.15	8.03	20.35	192
3B12DB	0.625	0.98	3/16x3/16x0.75	13.62	8.03	21.10	198
3B14DA	0.500	0.98	1/8x1/8x0.71	13.82	9.06	21.02	198
3B14DB	0.625	0.98	3/16x3/16x0.75	14.17	9.06	21.65	207
3C14DA	0.500	0.98	1/8x1/8x0.71	16.14	9.06	24.53	302
3C14DB	0.625	0.98	3/16x3/16x0.75	16.50	9.06	25.16	311
3C14DC	0.625	0.98	3/16x3/16x0.75	17.05	9.06	25.39	313
3C16DA	0.625	0.98	3/16x3/16x0.75	17.40	11.81	26.06	362
3C16DB	0.625	0.98	3/16x3/16x0.75	17.95	11.81	26.29	367
3D16DA	0.625	0.98	3/16x3/16x0.75	20.24	11.81	30.08	509
3D16DB	0.625	0.98	3/16x3/16x0.75	20.79	11.81	30.31	514
3D16DC	0.750	1.38	3/16x3/16x1.02	20.87	11.81	31.22	529
3D17DA	0.625	0.98	3/16x3/16x0.75	20.04	13.39	29.88	540
3D17DB	0.625	0.98	3/16x3/16x0.75	20.59	13.39	30.12	545
3D17DC	0.750	1.38	3/16x3/16x1.02	20.75	13.39	31.10	556
3E17DA	0.625	0.98	3/16x3/16x0.75	21.02	13.39	31.85	703
3E17DB	0.625	0.98	3/16x3/16x0.75	21.57	13.39	32.09	708
3E17DC	0.750	1.38	3/16x3/16x1.02	21.73	13.39	33.07	719

NEMA C-Face Adapter	ØAJ	ØAK	ØBD	BB	ØBF
42C-48C	3.75	3.00	4.33	-	0.28
56C-145TC	5.87	4.50	6.69	-	0.43
182TC-256TC	7.25	8.50	8.98	0.22	0.55

Speed Reducers

Dimensions

Dimensions shown are for reference only and are subject to change without notice, unless certified. Certified prints are available after receipt of an order; consult factory.



This page intentionally left blank.

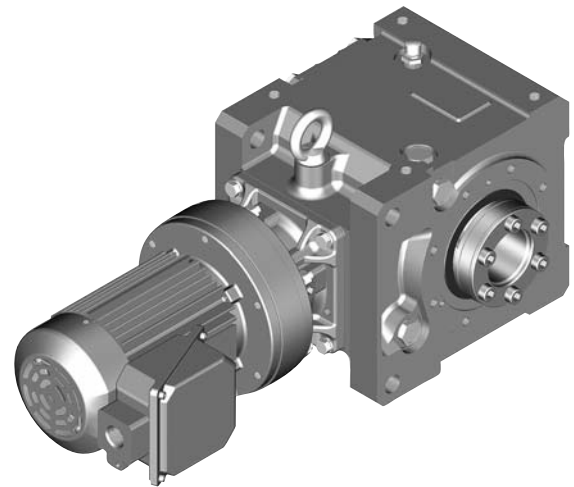
Speed  
Reducers



# 3

## Gearmotors

---



Gearmotors

How to  
Select

# How to select a Gearmotor

## Step 1: Collect data about your application

Before starting you need to know the:

- **Application (e.g. Conveyor, Mixer, etc.)**
- **Hours of Operation per day**
- **Motor Horsepower (HP) and Speed (RPM)**
- **Desired Output Speed**
- **Mounting Position and Style**
- **Overhung or Thrust Loads**
- **Bore Dimensions, inch or metric**
- **Electrical Specifications**

## Step 2: Choose a Mounting Position

Find the correct Mounting Position from the *Mounting Positions Table* on the right.

## Step 3: Select a Frame Size

**3A:** Find the **Load Classification** of your application in the *AGMA Load Classification Tables* on pages 3.6 and 3.7.

**3B:** Go to the *Gearmotor Selection Table* that corresponds to the desired **Mounting Position** and **Motor HP**. Find the **Output Speed** closest to the desired output speed.

**3C:** Locate the **Service Class** in the *Gearmotor Selection Table* for your application and select the **Frame Size SELECTION** that matches the HP, Output Speed, and Service Class.

## Step 4: Verify Dimensions

Use the Dimensions information on pages 3.38–3.45 to verify that the selected Frame Size is appropriate.

## Step 5: Choose a Bushing Bore Size

Choose a Taper Grip® Bushing Bore Size from the *Stock Bushing Bore Size Table*.

## Step 6: Choose Options

The following options may apply:

**Brakemotor**

**Washdown Modifications**

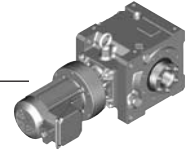
**Breather**

Please see the *Cyclo BBB pricelist*, or visit our website at [www.smcyclo.com](http://www.smcyclo.com) for available modifications.

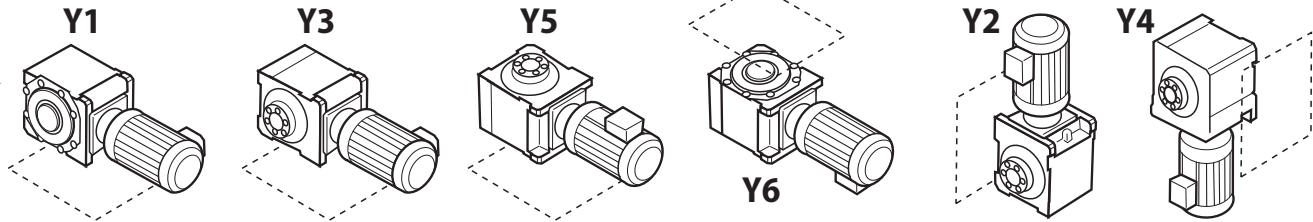
## Step 7: Configure a Model Number

Go to page 3.4 to configure a model number.

**Note:** You will use the information you gather from the procedure on this page to Configure a Model Number.



Mounting Positions

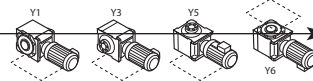


Select a Frame Size

Gearmotors

60 Hz, 1750 RPM Gearmotor Selection Tables

• Mounting Position



Horizontal Motor Shaft  
Y1, Y3, Y5, Y6 Mounting Positions

• Motor HP

1/4 HP

• Output Speed

• Service Class

• SELECTION

Output Speed RPM	Output Torque in•lb	Service Factor SF	AGMA Class	SELECTION			Overhung Load (lbs)		Dimension Page LHYM
				HP Symbol	Frame Size	Ratio	Hollow Shaft	Solid Shaft	
2.56	5350	1.57	II	02	<b>3A10DA</b>	683	1120	990	3.42-43
		1.64	II	02	<b>3A12DA</b>	683	1120	990	3.42-43
		2.15	III	02	<b>3B12DA</b>	683	2070	1640	3.42-43
2.56	5350	1.32	I	02	<b>3A10DA</b>	809	1120	990	3.42-43
		1.38	I	02	<b>3A12DA</b>	809	1120	990	3.42-43
		2.15	III	02	<b>3B12DA</b>	809	2070	1640	3.42-43
1.83	7490	1.12	I	02	<b>3A10DA</b>	956	1120	990	3.42-43
		1.17	I	02	<b>3A12DA</b>	956	1120	990	3.42-43
		2.15	III	02	<b>3B12DA</b>	956	2070	1640	3.42-43
1.57	8730	1.00	I	02	<b>3A12DA</b>	1117	1120	990	3.42-43
		2.00	III	02	<b>3B12DA</b>	1117	2070	1640	3.42-43
		2.00	III	02	<b>3B14DA</b>	1117	2070	1640	3.42-43
1.33	10300	0.85	-	02	<b>3A12DA</b>	1320	1120	990	3.42-43
		1.69	II	02	<b>3B12DA</b>	1320	2070	1640	3.42-43
		1.69	II	02	<b>3B14DA</b>	1320	2070	1640	3.42-43
1.06	12930	2.15	III	02	<b>3C14DA</b>	1320	3480	2850	3.42-43
		1.35	I	02	<b>3B12DA</b>	1656	2070	1640	3.42-43
		1.35	I	02	<b>3B14DA</b>	1656	2070	1640	3.42-43
		2.15	III	02	<b>3C14DA</b>	1656	3480	2850	3.42-43

Gearmotors

Selection Tables

Gearmotors

How to Select

STOCK BUSHING BORES

Size	Inch Sizes	Metric Sizes	Min. Bore
A	1 <sup>15</sup> / <sub>16</sub> , 2 <sup>3</sup> / <sub>16</sub>	50, 55	1 <sup>15</sup> / <sub>16</sub>
B	2 <sup>3</sup> / <sub>16</sub> , 2 <sup>7</sup> / <sub>16</sub>	60, 65	1 <sup>15</sup> / <sub>16</sub>
C	2 <sup>7</sup> / <sub>16</sub> , 2 <sup>15</sup> / <sub>16</sub>	65, 75	2 <sup>3</sup> / <sub>16</sub>
D	2 <sup>15</sup> / <sub>16</sub> , 3 <sup>1</sup> / <sub>16</sub>	75, 85	2 <sup>7</sup> / <sub>16</sub>
E	3 <sup>7</sup> / <sub>16</sub> , 3 <sup>15</sup> / <sub>16</sub>	90, 100	2 <sup>15</sup> / <sub>16</sub>

For special circumstances in selecting a **Frame Size** such as:

- Overhung Load
- Thrust Loads
- Radial Loads
- Shock Loading

Consult Appendix, pages 5.2-5.5.

**If Overhung Load is present, any Overhung Load must be checked against the capacity of the selection.**



# Configure a Model Number

## Output Shaft Orientation

Type	Prefix
Horizontal	H
Vertical	V
Vertical Up (Solid Shaft)	W

## Mounting Style

Type	Prefix
Shaft Mount (Hollow Shaft)	Y
Flange (Solid Shaft)	F
Foot (Solid Shaft)	H

## Input Connection

Input Connection	Prefix	
	Reducer	Gearmotor
Integral Motor	M	

## Modification

	Prefix
Special	S
Standard	

## Gearmotor HP (applies only to 1750 RPM)

HP	Prefix
1/8	01
1/4	02
1/3	03
1/2	05
3/4	08
1	1
1 1/2	1H
2	2
3	3
5	5
7 1/2	8
10	10
15	15
20	20
25	25
30	30
40	40

## Frame Size

Single Reduction				
3A100	3A140	3B145	3C160	3D165
3A105	3A145	3B160	3C165	3D170
3A110	3B120	3B165	3C170	3D175
3A115	3B125	3C140	3C175	3E170
3A120	3B140	3C145	3D160	3E175
3A125				
Double Reduction				
3A10DA	3B14DA	3C14DC	3D16DB	3D17DC
3A12DA	3B14DB	3C16DA	3D16DC	3E17DA
3A12DB	3C14DA	3C16DB	3D17DA	3E17DB
3B12DA	3C14DB	3D16DA	3D17DB	3E17DC
3B12DB				

## AGMA Class

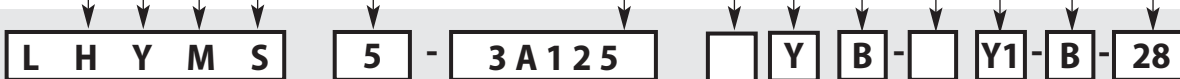
Class	Suffix
I	A
II	B
III	C

## Motor Specification

Specification	Suffix
AF Motor (Adj. Frequency)	AV
Single Phase Motor	SG
Servo Motor	SV
Three Phase Motor	

## Brake

	Suffix
With Brake	B
No Brake	-



When ordering, the following information should be included:

- Motor Specification (230/460 VAC 60 Hz is supplied, unless otherwise specified)
- Bushing Bore size must be supplied




Optional conduit box positions must be specified, otherwise Y1 is supplied.

Gearmotors

Nomenclature

# Nomenclature

### Output Shaft Direction (Shafted Model Only)

Projects to Left Side	<b>L</b>	
Projects to Right Side	<b>R</b>	
Projects to Both Left/Right Sides	<b>T</b>	

*Note: When viewed from motor end.*

### Shaft Specifications

Input Shaft	OUTPUT SHAFT		Suffix
	Hollow	Solid	
mm	Key (mm)	mm	
Inch	Key (Inch)	Inch	<b>K</b>
mm	Taper Grip		<b>M</b>
Inch	Taper Grip		<b>Y</b>

### Nominal and Exact Ratio

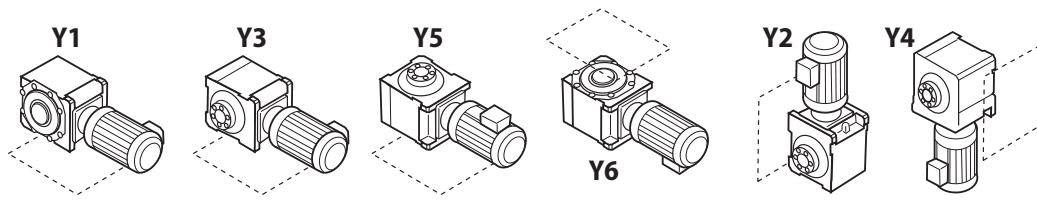
BBB with Planetary Input				BBB with Cyclo Input Single Reduction			
Input Ratio	Nominal Ratio	BBB Frame Sz.	Exact Ratio	Input Ratio	Nominal Ratio	BBB Frame Sz.	Exact Ratio
3	11	3A10	10.500	6	21		21.0
N/A	N/A	3A11	N/A	8	28		28.0
3	11	3A12	10.500	11	39		38.5
3	11	3A14	10.885	13	46		45.5
3	11	3B12	10.500	15	53		52.5
3	11	3B14	10.885	17	60		59.5
3	11	3B16	10.850	21	74		73.5
3	11	3C14	10.885	25	88	ALL	87.5
3	11	3C17	10.850	29	102		101.5
3	11	3D16	10.850	35	123		122.5
3	11	3E17	10.850	43	151		150.5
5	18	3A10	16.800	51	179		178.5
N/A	N/A	3A11	N/A	59	207		206.5
5	18	3A12	17.115	71	249		248.5
5	18	3A14	17.500	87	305		304.5
5	18	3B12	17.115				
5	18	3B14	17.500				
5	18	3B16	17.780				
5	18	3C14	17.500				
5	18	3C17	17.675				
5	18	3D16	17.780				
5	18	3E17	17.675				

Double Reduction			
Input Ratio	Nominal Ratio	BBB Frame Sz.	Exact Ratio
104	364		364.0
121	424		423.5
143	501		500.5
165	578		577.5
195	683		682.5
231	809		808.5
273	956		955.5
319	1117		1116.5
377	1320		1319.5
473	1656		1655.5
559	1957		1956.5
649	2272		2271.5
731	2559		2558.5
841	2944	ALL	2943.5
1003	3511		3510.5
1247	4365		4364.5
1479	5177		5176.5
1849	6472		6471.5
2065	7228		7227.5
2537	8880		8879.5
3045	10568		10657.5
3481	12184		12183.5
4437	15530		15529.5
5133	17966		17965.5
6177	21620		21619.5
7569	26492		26491.5

Gearmotors

Nomenclature



**Mounting Positions**

### Nominal and Exact Ratio

#### Nomenclature Example:

**LVYM – 3B125YB – AVY5 – 53**

- |                                       |                                       |
|---------------------------------------|---------------------------------------|
| <b>L</b> – Cyclo Bevel Buddybox       | <b>3B125</b> – Frame Size             |
| <b>V</b> – Vertical                   | <b>Y</b> – Taper-Grip® Bushing output |
| <b>Y</b> – Shaft Mount (Hollow Shaft) | <b>B</b> – AGMA Class II              |
| <b>M</b> – Integral Motor             | <b>AV</b> – Adj. Frequency Motor      |
| <b>5</b> – 5 HP, 1750 RPM             | <b>Y5</b> – Installation Position     |
|                                       | <b>53</b> – Ratio                     |

# AGMA Load Classifications: Gearmotors

## Gearmotor Classification

### GEARMOTOR CLASS

DURATION OF SERVICE	UNIFORM LOAD	MODERATE SHOCK LOAD	HEAVY SHOCK LOAD
Intermittent 3 Hr. per day	Class I	Class I	Class II
Up to 10 Hr. per day	Class I	Class II	Class III
24 Hr. per day	Class II	Class III	—

- Class I** For steady loads not exceeding normal motor rating, 8 to 10 hours per day. Moderate shock loads where service is intermittent (AGMA Service Factor: 1.0).
- Class II** For steady loads not exceeding normal motor rating and 24 hours per day service. Moderate shock loads for 8 hours per day (AGMA Service Factor: 1.4).
- Class III** For moderate shock loads for 24 hours per day. Heavy shock loads for 8 hours per day (AGMA Service Factor: 2.0).

Gearmotors

AGMA Tables

## Load Classification by INDUSTRY

Application	Class		Application	Class		Application	Class		Application	Class	
	Up to 10 Hr. per day	24 Hr. per day		Up to 10 Hr. per day	24 Hr. per day		Up to 10 Hr. per day	24 Hr. per day		Up to 10 Hr. per day	24 Hr. per day
<b>Brewing &amp; Distilling</b>			<b>Lumber Industry</b>			<b>Oil Well Pumping</b>	Refer to Factory		<b>Tire Building Machines</b>	Refer to Factory	
Bottling Machinery	I	II	Barkers—			Paraffin Filter Press	II	II	Tire, Tube Press		
Brew Kettles, Cont. Duty	—	II	Spindle Feed	Refer to Factory	Factory	Rotary Kilns	II	II	Openers	Refer to Factory	
Can Filling Machines	I	II	Barkers—	Refer to Factory	Factory	<b>Paper Mills</b>			Tubers & Stainers	II	II
Cookers—Cont. Duty	—	II	Main Drive	Refer to Factory	Factory	Agitators (Mixers)	II	II			
Mash Tubs—Cont. Duty	—	II	Carriage Drive	Refer to Factory	Factory	Barker—Auxiliaries—Hyd.	Refer to Factory	Factory	<b>Sewage Disposal</b>		
Scale Hoppers—Frequent Starts	II	II	Conveyors	II	III	Barker, Mechanical	Refer to Factory	Factory	Aerators	Refer to Factory	
			Burner	II	III	Barking Drum	Refer to Factory	Factory	Bar Screens	I	II
			Main or Heavy Duty	II	III	Beater & Pulper	—	II	Chemical Feeders	I	II
			Main Log	III	III	Bleacher	—	II	Collectors	I	II
			Re-Saw	II	III	Calenders	—	II	Dewatering Screens	II	II
<b>Clay Working Industry</b>			Merry-Go-Round	II	III	Calenders—Super	—	II	Grit Collectors	I	II
Brick Press	III	III	Slab	III	III	Converting Mach.—Except Cutters—Platers	—	II	Scum Breakers	II	II
Briquette Machines	III	III	Transfer	II	III	Conveyors	—	II	Slow or Rapid Mixers	II	II
Clay Working Machinery	II	II	Chains—Floor	II	III	Couch	—	II	Sludge Collectors	I	II
Pug Mills	II	II	Chains—Green	II	III	Cutters, Platers	—	II	Thickeners	II	II
			Cut-Off Saws—Chain	II	III	Cylinders	—	II	Vacuum Filters	II	II
			Cut-Off Saws—Drag	II	III	Dryers	—	II			
<b>Distilling (See Brewing)</b>			Debarking Drums	Refer to Factory	Factory	Felt Stretchers	—	II	<b>Textile Industry</b>		
			Feeds—Edger	II	III	Felt Whippers	—	III	Batchers	II	II
<b>Dredges</b>			Feeds—Gang	III	III	Jordans	—	II	Calenders	II	II
Cable Reels	II	—	Feeds—Trimmer	II	III	Log Haul	—	III	Card Machines	II	II
Conveyors	II	II	Log Deck	III	III	Presses	—	II	Cloth Finishing Machines (Calenders, Dryers, Pads, Tenters, Washers)		
Cutter Head Drives	III	III	Log Hauls—Incline, Well Type	III	III	Pulp Machine Reels	—	II	Dry Cans	II	II
Jig Drives	III	III	Log Turning Devices	III	III	Stock Chests	—	II	Dyeing Machinery	II	II
Maneuvering Winches	II	—	Planer Feed	II	III	Suction Rolls	—	II	Knitting Machinery	Refer to Factory	
Pumps	II	II	Planer Tilting Hoists	II	III	Washers & Thickeners	—	II	Looms, Mangles, Nappers	II	II
Screen Drives	III	III	Rolls—Live—Off Bearing—Roll Cases	III	III	Winders	—	II	Range Drives	Refer to Factory	
Stackers	II	II	Sorting Table	II	III	Rubber Industry			Soapers, Spinners	II	II
Utility Winches	II	—	Tipple Hoist	II	III	Mixer	III	III	Tenter Frames	II	II
			Transfers—Chain	II	III	Rubber Calender	II	II	Winders	II	II
<b>Food Industry</b>			Transfers—Craneway	II	III	Rubber Mill (2 or more)	II	II	Yarn Preparatory Machinery (Cards, Spinners, Slashers)		
Beet Slicers	II	II	Tray Drives	II	III	Sheeter	II	II			
Bottlings, Can Filling Mach.	I	II	<b>Oil Industry</b>								
Cereal Cookers	I	II	Chillers	II	II						
Dough Mixers	II	II									
Meat Grinders	II	II									



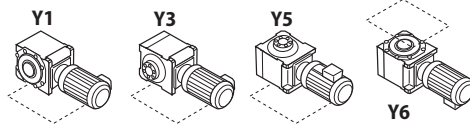
Load Classification by APPLICATION

Application	Class		Application	Class		Application	Class		Application	Class	
	Up to 10 Hr. per day	24 Hr. per day		Up to 10 Hr. per day	24 Hr. per day		Up to 10 Hr. per day	24 Hr. per day		Up to 10 Hr. per day	24 Hr. per day
<b>Agitators</b> Pure Liquids Liquids and Solids Liquids – Variable Density Density Semi-liquids – Variable Density	I	II	Jig Drives Maneuvering Winches Pumps Screen Drive Stackers Utility Winches	III	III	Tray Drives Veneer Lathe Drives	II	III	<b>Pullers</b> Barge Haul	III	III
<b>Blowers</b> Centrifugal Lobe Vane	I	II	<b>Elevators</b> Bucket – Uniform Load Bucket – Heavy Load Bucket – Continuous Centrifugal Discharge Escalators Freight Gravity Discharge Man Lifts Passenger Service – Hand Lift	I	II	<b>Machine Tools</b> Bending Roll Notching Press – Belt Driven Plate Planer Punch Press – Gear Driven Tapping Machines Other Machine Tools Main Drives Auxiliary Drives	II	II	<b>Pumps</b> Centrifugal Proportioning Reciprocating Single Acting 3 or more Cylinders Double Acting 2 or more Cylinders Single Acting 1 or 2 Cylinders Double Acting Single Cylinder Rotary – Gear Type – Lobe, Vane	I	II
<b>Brewing and Distilling</b> Bottling Machinery Brew Kettles – Continuous Duty Cookers – Continuous Duty Mash Tubs – Continuous Duty Scale Hopper Frequent Starts	I	II	<b>Fans</b> Centrifugal Cooling Towers Induced Draft Forced Draft Induced Draft Large (Mine, etc.) Large Industrial Light (Small Diameter)	II	II	<b>Metal Mills</b> Bridle Roll Drives Draw Bench – Carriage Draw Bench – Main Drive Forming Machines Pinch Dryer & Scrubber Rolls, Reversing Slitters Table Conveyors Non-Reversing Reversing Winding Reels – Strip Wire Drawing & Flattening Machine Wire Winding Machine	III	III	<b>Rubber Industry</b> Mixer Rubber Calender Rubber Mill (2 or more) Sheeter Tire Building Machines Tire & Tube Press Openers Tubers & Strainers	III	III
<b>Can Filling Machines</b>	I	II	<b>Feeders</b> Apron Belt Disc Reciprocating Screw	II	II	<b>Mills, Rotary Type</b> Ball Cement Kilns Dryers & Coolers Kilns Pebble Rod Tumbling Barrels	III	III	<b>Sewage Disposal Equipment</b> Aerators Bar Screens Chemical Feeders Collectors, Circuline or Straightline Dewatering Screens Grit Collectors Scum Breakers Slow or Rapid Mixers Sludge Collectors Thickeners Vacuum Filters	Refer to Factory	Factory
<b>Cane Knives</b>	II	II	<b>Food Industry</b> Beet Slicer Cereal Cooker Dough Mixer Meat Grinders	II	II	<b>Mixers</b> Concrete Mixers, Continuous Concrete Mixers, Intermittent Constant Density Variable Density	I	II	<b>Screens</b> Air Washing Rotary – Stone or Gravel Traveling Water Intake	I	II
<b>Car Dumpers</b>	III	–	<b>Generators – (Not Welding)</b>	I	II	<b>Oil Industry</b> Chillers Oil Well Pumping Paraffin Filter Press Rotary Kilns	II	II	<b>Slab Pushers</b> Steering Gear Stokers	II	II
<b>Car Pullers – Intermittent Duty</b>	I	–	<b>Hammer Mills</b>	III	III	<b>Paper Mills</b> Aerators Agitators (Mixers) Barker Auxiliaries, Hydraulic Barker, Mechanical Barking Drum Beater & Pulper Bleacher Calenders Calenders – Super Converting Machines, except Cutters, Platers Conveyors Conveyors, Log Couch Cutters, Platers Cylinders Dryers Felt Stretcher Felt Whipper Jordans Presses Pulp Machines, Reel Stock Chests Suction Roll Washers and Thickeners Winders	II	II	<b>Textile Industry</b> Batchers Calenders Card Machines Cloth Finishing Machines (Washers, Pads, Teners) (Dryers, Calenders, etc.) Dry Cans Dryers Dyeing Machinery Knitting Machines (Looms, etc.) Looms Mangles Nappers Pads Range Drives Slashers Soapers Spinners Teneter Frames Washers Winders (Other than Batchers) Yarn Preparatory Machines (Cards, Spinners, Slashers, etc.)	II	II
<b>Clarifiers</b>	I	II	<b>Laundry Washers</b> Reversing	II	II	<b>Printing Presses</b>	I	II	<b>Windlass</b>	II	II
<b>Classifiers</b>	II	II	<b>Laundry Tumblers</b>	II	II						
<b>Clay Working Machinery</b> Brick Press Briquette Machine Clay Working Machinery Pug Mill	III	III	<b>Line Shafts</b> Heavy Shock Load Moderate Shock Load Uniform Load	III	III						
<b>Compressors</b> Centrifugal Lobe Reciprocating Multi-Cylinder Single Cylinder	I	II	<b>Lumber Industry</b> Barkers – Spindle Feed Barkers – Main Drive Carriage Drive Conveyors – Burner Conveyors – Main or Heavy Duty Conveyors – Main Log Conveyors – Merry-Go-Round Conveyors – Slab Conveyors – Transfer Conveyors – Waste Chains – Floor Chains – Green Cut-Off Saws – Chain Cut-Off Saws – Drag Debarking Drums Feeds – Edger Feeds – Gang Feeds – Trimmer Log Deck Log Hauls – Incline Well Type Log Turning Devices Planer Feed Planer Tilting Hoists Rolls – Live – Off Brg. – Roll Cases Sorting Table Tipple Hoist Transfers – Chain Transfers – Craneway	Refer to Factory	Refer to Factory						
<b>Conveyors – Uniformly Loaded or Fed</b> Apron Assembly Belt Bucket Chain Flight Oven Screw	I	II									
<b>Conveyors – Heavy Duty Not Uniformly Fed</b> Apron Assembly Belt Bucket Chain Flight Live Roll (Package) Oven Reciprocating Screw Shaker	II	II									
<b>Cranes and Hoists</b> Main Hoists Heavy Duty Medium Duty Reversing Skip Hoists Trolley Drive Bridge Drive	III	III									
<b>Crushers</b> Ore Stone	III	III									
<b>Dredges</b> Cable Reels Conveyors Cutter Head Drives	II	–									

AGIMA Tables

# Gearmotor Selection Tables 60 Hz, 1750 RPM

## Horizontal Motor Shaft Y1, Y3, Y5, Y6 Mounting Positions



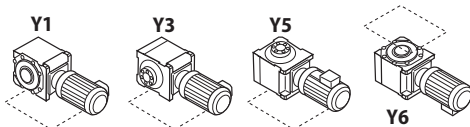
### 1/8 HP

Output Speed RPM	Output Torque in•lb	Service Factor		SELECTION			Overhung Load (lbs)		Dimension Page LHYM
		SF	AGMA Class	HP Symbol	Frame Size	Ratio	Hollow Shaft	Solid Shaft	
4.81	1425	4.61	III	01	<b>3A10DA</b>	364	1120	990	3.42-43
4.13	1660	4.61	III	01	<b>3A10DA</b>	424	1120	990	3.42-43
3.50	1960	4.58	III	01	<b>3A10DA</b>	501	1120	990	3.42-43
3.03	2260	3.97	III	01	<b>3A10DA</b>	578	1120	990	3.42-43
2.56	2670	3.36	III	01	<b>3A10DA</b>	683	1120	990	3.42-43
2.16	3170	2.84	III	01	<b>3A10DA</b>	809	1120	990	3.42-43
1.83	3745	2.40	III	01	<b>3A10DA</b>	956	1120	990	3.42-43
1.57	4365	2.06	III	01	<b>3A10DA</b>	1117	1120	990	3.42-43
		2.59	III	01	<b>3A12DA</b>	1117	1120	990	3.42-43
1.33	5150	1.74	II	01	<b>3A10DA</b>	1320	1120	990	3.42-43
		2.20	III	01	<b>3A12DA</b>	1320	1120	990	3.42-43
		3.65	III	01	<b>3B12DA</b>	1320	2070	1640	3.42-43
1.06	6465	1.38	I	01	<b>3A10DA</b>	1656	1120	990	3.42-43
		1.75	II	01	<b>3A12DA</b>	1656	1120	990	3.42-43
		2.91	III	01	<b>3B12DA</b>	1656	2070	1640	3.42-43
0.894	7665	1.18	I	01	<b>3A10DA</b>	1957	1120	990	3.42-43
		1.48	II	01	<b>3A12DA</b>	1957	1120	990	3.42-43
		2.46	III	01	<b>3B12DA</b>	1957	2070	1640	3.42-43
0.770	8900	1.00	I	01	<b>3A12DA</b>	2272	1120	990	3.42-43
		2.14	III	01	<b>3B12DA</b>	2272	2070	1640	3.42-43
0.684	10020	1.14	I	01	<b>3A12DA</b>	2559	1120	990	3.42-43
		1.88	II	01	<b>3B12DA</b>	2559	2070	1640	3.42-43
0.585	11715	1.64	II	01	<b>3B12DA</b>	2944	2070	1640	3.42-43
0.498	13760	1.37	I	01	<b>3B12DA</b>	3511	2070	1640	3.42-43
0.401	17090	1.10	I	01	<b>3B12DA</b>	4365	2070	1640	3.42-43

### 1/4 HP

Output Speed RPM	Output Torque in•lb	Service Factor		SELECTION			Overhung Load (lbs)		Dimension Page LHYM
		SF	AGMA Class	HP Symbol	Frame Size	Ratio	Hollow Shaft	Solid Shaft	
8.45	1715	3.79	III	02	<b>3A105</b>	207	1120	990	3.38-39
7.03	2061	3.01	III	02	<b>3A105</b>	249	1120	990	3.38-39
5.74	2525	3.03	III	02	<b>3A105</b>	305	1120	990	3.38-39
4.81	2850	2.30	III	02	<b>3A10DA</b>	364	1120	990	3.42-43
4.20	3451	1.13	I	02	<b>3A100</b>	417	1120	990	3.38-39
		1.54	II	02	<b>3A105</b>	417	1120	990	3.38-39
4.13	3319	2.30	III	02	<b>3A10DA</b>	424	1120	990	3.42-43
3.50	3925	2.29	III	02	<b>3A10DA</b>	501	1120	990	3.42-43
3.03	4525	1.98	II	02	<b>3A10DA</b>	578	1120	990	3.42-43
		2.30	III	02	<b>3A12DA</b>	578	1120	990	3.42-43

# 60 Hz, 1750 RPM Gearmotor Selection Tables



## Horizontal Motor Shaft Y1, Y3, Y5, Y6 Mounting Positions

**1/4 HP**

Output Speed RPM	Output Torque in•lb	Service Factor		SELECTION			Overhung Load (lbs)		Dimension Page LHYM
		SF	AGMA Class	HP Symbol	Frame Size	Ratio	Hollow Shaft	Solid Shaft	
2.56	5350	1.68	II	02	<b>3A10DA</b>	683	1120	990	3.42-43
		2.12	III	02	<b>3A12DA</b>	683	1120	990	3.42-43
		2.30	III	02	<b>3B12DA</b>	683	2070	1640	3.42-43
2.16	5350	1.42	II	02	<b>3A10DA</b>	809	1120	990	3.42-43
		1.79	II	02	<b>3A12DA</b>	809	1120	990	3.42-43
		2.30	III	02	<b>3B12DA</b>	809	2070	1640	3.42-43
1.83	7490	1.20	I	02	<b>3A10DA</b>	956	1120	990	3.42-43
		1.52	II	02	<b>3A12DA</b>	956	1120	990	3.42-43
		2.30	III	02	<b>3B12DA</b>	956	2070	1640	3.42-43
1.57	8730	1.03	I	02	<b>3A10DA</b>	1117	1120	990	3.42-43
		2.16	III	02	<b>3B12DA</b>	1117	2070	1640	3.42-43
		2.30	III	02	<b>3B14DA</b>	1117	2070	1640	3.42-43
1.33	10300	1.10	I	02	<b>3A12DA</b>	1320	1120	990	3.42-43
		1.82	II	02	<b>3B12DA</b>	1320	2070	1640	3.42-43
		2.19	III	02	<b>3B14DA</b>	1320	2070	1640	3.42-43
		2.30	III	02	<b>3C14DA</b>	1320	3480	2850	3.42-43
1.06	12930	1.46	II	02	<b>3B12DA</b>	1656	2070	1640	3.42-43
		1.74	II	02	<b>3B14DA</b>	1656	2070	1640	3.42-43
		2.30	III	02	<b>3C14DA</b>	1656	3480	2850	3.42-43
0.894	15330	1.23	I	02	<b>3B12DA</b>	1957	2070	1640	3.42-43
		1.48	II	02	<b>3B14DA</b>	1957	2070	1640	3.42-43
		2.30	III	02	<b>3C14DA</b>	1957	3480	2850	3.42-43
0.770	17800	1.06	I	02	<b>3B12DA</b>	2272	2070	1640	3.42-43
		2.30	III	02	<b>3C14DA</b>	2272	3480	2850	3.42-43
0.684	20040	1.13	I	02	<b>3B14DA</b>	2559	2070	1640	3.42-43
		2.05	III	02	<b>3C14DA</b>	2559	3480	2850	3.42-43
0.594	23075	1.62	II	02	<b>3C14DA</b>	2944	3480	2850	3.42-43
0.498	27525	1.49	II	02	<b>3C14DA</b>	3511	3480	2850	3.42-43
0.401	34180	1.20	I	02	<b>3C14DA</b>	4365	3480	2850	3.42-43
0.242	56640	1.12	I	02	<b>3D16DA</b>	7228	4810	3930	3.44-45
0.197	69583	1.36	I	02	<b>3E17DA</b>	8880	5170	4110	3.44-45
0.164	83585	0.13	I	02	<b>3E17DA</b>	10658	5170	4110	3.44-45

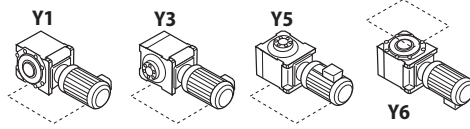
Gearmotors  
Selection  
Tables

**1/3 HP**

Output Speed RPM	Output Torque in•lb	Service Factor		SELECTION			Overhung Load (lbs)		Dimension Page LHYM
		SF	AGMA Class	HP Symbol	Frame Size	Ratio	Hollow Shaft	Solid Shaft	
9.78	1956	3.12	III	03	<b>3A105</b>	179	1120	990	3.38-39
8.45	2264	2.85	III	03	<b>3A105</b>	207	1120	990	3.38-39
7.03	2721	1.78	II	03	<b>3A100</b>	249	1120	990	3.38-39
		2.26	III	03	<b>3A105</b>	249	1120	990	3.38-39
5.74	3333	1.74	II	03	<b>3A100</b>	305	1120	990	3.38-39
		2.27	III	03	<b>3A105</b>	305	1120	990	3.38-39

# Gearmotor Selection Tables 60 Hz, 1750 RPM

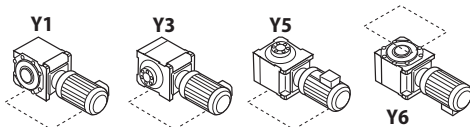
## Horizontal Motor Shaft Y1, Y3, Y5, Y6 Mounting Positions



### 1/3 HP

Output Speed RPM	Output Torque in•lb	Service Factor		SELECTION			Overhung Load (lbs)		Dimension Page LHYM
		SF	AGMA Class	HP Symbol	Frame Size	Ratio	Hollow Shaft	Solid Shaft	
4.81	3760	1.73	II	03	<b>3A10DA</b>	364	1120	990	3.42-43
		2.99	III	03	<b>3A12DB</b>	364	1120	990	3.42-43
4.20	4555	0.85	-	03	<b>3A100</b>	417	1120	990	3.38-39
		1.15	I	03	<b>3A105</b>	417	1120	990	3.38-39
4.13	4380	1.73	II	03	<b>3A10DA</b>	424	1120	990	3.42-43
		2.57	III	03	<b>3A12DB</b>	424	1120	990	3.42-43
3.50	5180	1.72	II	03	<b>3A10DA</b>	501	1120	990	3.42-43
		1.73	II	03	<b>3A12DA</b>	501	1120	990	3.42-43
		2.17	III	03	<b>3A12DB</b>	501	1120	990	3.42-43
3.03	5970	1.49	II	03	<b>3A10DA</b>	578	1120	990	3.42-43
		1.73	II	03	<b>3A12DA</b>	578	1120	990	3.42-43
		1.88	II	03	<b>3A12DB</b>	578	1120	990	3.42-43
		3.12	III	03	<b>3B12DB</b>	578	2070	1640	3.42-43
2.56	7070	1.26	I	03	<b>3A10DA</b>	683	1120	990	3.42-43
		1.59	II	03	<b>3A12DA</b>	683	1120	990	3.42-43
		1.73	II	03	<b>3B12DA</b>	683	2070	1640	3.42-43
		2.65	III	03	<b>3B12DB</b>	683	2070	1640	3.42-43
2.16	8375	1.07	I	03	<b>3A10DA</b>	809	1120	990	3.42-43
		1.34	I	03	<b>3A12DA</b>	809	1120	990	3.42-43
		1.73	II	03	<b>3B12DA</b>	809	2070	1640	3.42-43
		2.23	III	03	<b>3B12DB</b>	809	2070	1640	3.42-43
1.83	9885	1.14	I	03	<b>3A12DA</b>	956	1120	990	3.42-43
		1.73	II	03	<b>3B12DA</b>	956	2070	1640	3.42-43
		1.89	II	03	<b>3B12DB</b>	956	2070	1640	3.42-43
		2.27	III	03	<b>3B14DB</b>	956	2070	1640	3.42-43
1.57	11525	0.97	-	03	<b>3A12DA</b>	1117	1120	990	3.42-43
		1.62	II	03	<b>3B12DA</b>	1117	2070	1640	3.42-43
		1.73	II	03	<b>3B14DA</b>	1117	2070	1640	3.42-43
		3.51	III	03	<b>3C14DB</b>	1117	3480	2850	3.42-43
1.33	13600	1.37	I	03	<b>3B12DA</b>	1320	2070	1640	3.42-43
		1.64	II	03	<b>3B14DA</b>	1320	2070	1640	3.42-43
		1.73	II	03	<b>3C14DA</b>	1320	3480	2850	3.42-43
		2.98	III	03	<b>3C14DB</b>	1320	3480	2850	3.42-43
1.06	17070	1.09	I	03	<b>3B12DA</b>	1656	2070	1640	3.42-43
		1.31	I	03	<b>3B14DA</b>	1656	2070	1640	3.42-43
		1.73	II	03	<b>3C14DA</b>	1656	3480	2850	3.42-43
		2.37	III	03	<b>3C14DB</b>	1656	3480	2850	3.42-43
0.894	20240	1.11	I	03	<b>3B14DA</b>	1957	2070	1640	3.42-43
		1.73	II	03	<b>3C14DA</b>	1957	3480	2850	3.42-43
0.770	23500	1.73	II	03	<b>3C14DA</b>	2272	3480	2850	3.42-43
0.684	26450	1.54	II	03	<b>3C14DA</b>	2559	3480	2850	3.42-43
0.594	30460	1.22	I	03	<b>3C14DA</b>	2944	3480	2850	3.42-43
0.498	36330	1.12	I	03	<b>3C14DA</b>	3511	3480	2850	3.42-43

# 60 Hz, 1750 RPM Gearmotor Selection Tables



## Horizontal Motor Shaft Y1, Y3, Y5, Y6 Mounting Positions

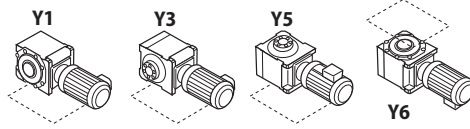
**1/2 HP**

Output Speed RPM	Output Torque in•lb	Service Factor		SELECTION			Overhung Load (lbs)		Dimension Page LHYM
		SF	AGMA Class	HP Symbol	Frame Size	Ratio	Hollow Shaft	Solid Shaft	
11.6	2500	2.90	III	05	<b>3A105</b>	151	1120	990	3.38-39
9.78	2964	1.50	II	05	<b>3A100</b>	179	1120	990	3.38-39
		2.08	III	05	<b>3A105</b>	179	1120	990	3.38-39
8.45	3430	1.38	I	05	<b>3A100</b>	207	1120	990	3.38-39
		1.90	II	05	<b>3A105</b>	207	1120	990	3.38-39
		2.30	III	05	<b>3A110</b>	207	1120	990	3.38-39
7.03	4123	1.17	I	05	<b>3A100</b>	249	1120	990	3.38-39
		1.50	II	05	<b>3A105</b>	249	1120	990	3.38-39
		2.04	III	05	<b>3A115</b>	249	1120	990	3.38-39
5.74	5050	1.16	I	05	<b>3A100</b>	305	1120	990	3.38-39
		1.52	II	05	<b>3A105</b>	305	1120	990	3.38-39
		2.54	III	05	<b>3B120</b>	305	2070	1640	3.38-39
4.81	5700	1.15	I	05	<b>3A10DA</b>	364	1120	990	3.42-43
		1.99	II	05	<b>3A12DB</b>	364	1120	990	3.42-43
		3.30	III	05	<b>3B12DB</b>	364	2070	1640	3.42-43
4.13	6635	1.15	I	05	<b>3A10DA</b>	424	1120	990	3.42-43
		1.71	II	05	<b>3A12DB</b>	424	1120	990	3.42-43
		2.80	III	05	<b>3B12DB</b>	424	2070	1640	3.42-43
3.50	7855	1.15	I	05	<b>3A10DA</b>	501	1120	990	3.42-43
		1.15	I	05	<b>3A12DA</b>	501	1120	990	3.42-43
		2.40	III	05	<b>3B12DB</b>	501	2070	1640	3.42-43
3.03	9050	1.15	I	05	<b>3A12DA</b>	578	2070	1640	3.42-43
		1.25	I	05	<b>3A12DB</b>	578	2070	1640	3.42-43
		2.08	III	05	<b>3B12DB</b>	578	2070	1640	3.42-43
2.56	10710	1.06	I	05	<b>3A12DA</b>	683	1120	990	3.42-43
		1.76	II	05	<b>3B12DB</b>	683	2070	1640	3.42-43
		2.12	III	05	<b>3B14DB</b>	683	2070	1640	3.42-43
		3.80	III	05	<b>3C14DB</b>	683	3480	2850	3.42-43
2.16	12690	1.15	I	05	<b>3B12DA</b>	809	2070	1640	3.42-43
		1.49	II	05	<b>3B12DB</b>	809	2070	1640	3.42-43
		3.16	III	05	<b>3C14DB</b>	809	3480	2850	3.42-43
1.83	14980	1.15	I	05	<b>3B12DA</b>	956	2070	1640	3.42-43
		1.51	II	05	<b>3B14DB</b>	956	2070	1640	3.42-43
		2.68	III	05	<b>3C14DB</b>	956	3480	2850	3.42-43
1.57	17460	1.08	I	05	<b>3B12DA</b>	1117	2070	1640	3.42-43
		1.29	I	05	<b>3B14DB</b>	1117	2070	1640	3.42-43
		2.34	III	05	<b>3C14DB</b>	1117	3480	2855	3.42-43
1.33	20610	1.15	I	05	<b>3C14DA</b>	1320	3480	2850	3.42-43
		1.98	II	05	<b>3C14DB</b>	1320	3480	2850	3.42-43
		2.18	III	05	<b>3C16DA</b>	1320	3480	2850	3.44-45
1.06	25860	1.15	I	05	<b>3C14DA</b>	1656	3480	2850	3.42-43
		1.74	II	05	<b>3C16DA</b>	1656	3480	2850	3.42-43
		2.42	III	05	<b>3D16DA</b>	1656	4810	3930	3.44-45

Gearmotors  
Selection Tables

# Gearmotor Selection Tables 60 Hz, 1750 RPM

## Horizontal Motor Shaft Y1, Y3, Y5, Y6 Mounting Positions



### 1/2 HP

Output Speed RPM	Output Torque in•lb	Service Factor		SELECTION			Overhung Load (lbs)		Dimension Page LHYM
		SF	AGMA Class	HP Symbol	Frame Size	Ratio	Hollow Shaft	Solid Shaft	
0.894	30660	1.15	I	05	<b>3C14DA</b>	1957	3480	2850	3.42-43
		2.06	III	05	<b>3D16DA</b>	1957	4810	3930	3.44-45
		2.50	III	05	<b>3D17DA</b>	1957	4810	3930	3.44-45
0.770	35600	1.77	II	05	<b>3D16DA</b>	2272	4810	3930	3.44-45
		2.16	III	05	<b>3D17DA</b>	2272	4810	3930	3.44-45
		2.66	III	05	<b>3E17DA</b>	2272	5170	4110	3.44-45
0.684	40080	1.02	I	05	<b>3C14DA</b>	2559	4810	3930	3.44-45
		1.57	II	05	<b>3D16DA</b>	2559	4810	3930	3.44-45
		2.36	III	05	<b>3E17DA</b>	2559	5170	4110	3.44-45
0.594	46150	1.36	I	05	<b>3D16DA</b>	2944	4810	3930	3.44-45
		2.04	III	05	<b>3E17DA</b>	2944	5170	4110	3.44-45
0.498	55050	1.14	I	05	<b>3D16DB</b>	3511	4810	3930	3.44-45
		1.40	II	05	<b>3D17DA</b>	3511	4810	3930	3.44-45
		1.71	II	05	<b>3E17DA</b>	3511	5170	4110	3.44-45
0.401	68370	1.38	I	05	<b>3E17DA</b>	4365	5170	4110	3.44-45
0.338	81100	1.16	I	05	<b>3E17DA</b>	5177	5170	4110	3.44-45

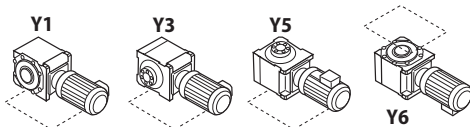
Gearmotors

Selection Tables

### 3/4 HP

Output Speed RPM	Output Torque in•lb	Service Factor		SELECTION			Overhung Load (lbs)		Dimension Page LHYM
		SF	AGMA Class	HP Symbol	Frame Size	Ratio	Hollow Shaft	Solid Shaft	
19.9	2185	2.99	III	08	<b>3A105</b>	88	1120	990	3.38-39
17.2	2528	2.84	III	08	<b>3A105</b>	102	1120	990	3.38-39
14.2	3062	2.15	III	08	<b>3A105</b>	123	1120	990	3.38-39
11.6	3748	1.40	II	08	<b>3A100</b>	151	1120	990	3.38-39
		2.32	III	08	<b>3A110</b>	151	1120	990	3.38-39
9.78	4446	1.00	I	08	<b>3A100</b>	179	1120	990	3.38-39
		1.39	I	08	<b>3A105</b>	179	1120	990	3.38-39
		1.69	II	08	<b>3A110</b>	179	1120	990	3.38-39
		2.13	III	08	<b>3A125</b>	179	1120	990	3.38-39
8.45	5146	1.27	I	08	<b>3A105</b>	207	1120	990	3.38-39
		1.53	II	08	<b>3A110</b>	207	1120	990	3.38-39
		2.32	III	08	<b>3B120</b>	207	2070	1640	3.38-39
7.03	6185	1.00	I	08	<b>3A105</b>	249	1120	990	3.38-39
		1.20	I	08	<b>3A110</b>	249	1120	990	3.38-39
		1.36	I	08	<b>3A115</b>	249	1120	990	3.38-39
		1.53	II	08	<b>3A125</b>	249	1120	990	3.38-39
		2.15	III	08	<b>3B125</b>	249	2070	1640	3.38-39
5.74	7576	1.01	I	08	<b>3A105</b>	305	1120	990	3.38-39
		1.25	I	08	<b>3A115</b>	305	1120	990	3.38-39
		1.69	II	08	<b>3B120</b>	305	2070	1640	3.38-39
		2.03	III	08	<b>3B125</b>	305	2070	1640	3.38-39

# 60 Hz, 1750 RPM Gearmotor Selection Tables



## Horizontal Motor Shaft Y1, Y3, Y5, Y6 Mounting Positions

**3/4 HP**

Output Speed RPM	Output Torque in•lb	Service Factor		SELECTION			Overhung Load (lbs)		Dimension Page LHYM
		SF	AGMA Class	HP Symbol	Frame Size	Ratio	Hollow Shaft	Solid Shaft	
4.81	8550	1.33	I	08	<b>3A12DB</b>	364	1120	990	3.42-43
		2.20	III	08	<b>3B12DB</b>	364	2070	1640	3.42-43
4.13	9955	1.14	I	08	<b>3A12DB</b>	424	1120	990	3.42-43
		1.87	II	08	<b>3B12DB</b>	424	2070	1640	3.42-43
		2.27	III	08	<b>3B14DB</b>	424	2070	1640	3.42-43
3.50	11780	1.60	II	08	<b>3B12DB</b>	501	2070	1640	3.42-43
		1.92	II	08	<b>3B14DB</b>	501	2070	1640	3.42-43
		2.85	III	08	<b>3C14DB</b>	501	3480	2850	3.42-43
3.03	13570	1.39	I	08	<b>3B12DB</b>	578	2070	1640	3.42-43
		1.67	II	08	<b>3B14DB</b>	578	2070	1640	3.42-43
		2.85	III	08	<b>3C14DB</b>	578	3480	2850	3.42-43
2.56	16060	1.18	I	08	<b>3B12DB</b>	683	2070	1640	3.42-43
		1.41	II	08	<b>3B14DB</b>	683	2070	1640	3.42-43
		2.53	III	08	<b>3C14DB</b>	683	3480	2850	3.42-43
2.16	19040	0.99	-	08	<b>3B12DB</b>	809	2070	1640	3.42-43
		1.19	I	08	<b>3B14DB</b>	809	2070	1640	3.42-43
		2.11	III	08	<b>3C14DB</b>	809	3480	2850	3.42-43
1.83	22470	1.79	II	08	<b>3C14DB</b>	956	3480	2850	3.42-43
		2.01	III	08	<b>3C16DA</b>	956	3480	2850	3.42-43
		2.80	III	08	<b>3D16DA</b>	956	4810	3930	3.44-45
1.57	26190	1.56	II	08	<b>3C14DB</b>	1117	3480	2850	3.42-43
		2.40	III	08	<b>3D16DA</b>	1117	4810	3930	3.44-45
1.33	30920	1.32	I	08	<b>3C14DB</b>	1320	3480	2850	3.42-43
		2.03	III	08	<b>3D16DA</b>	1320	4810	3090	3.44-45
		2.48	III	08	<b>3D17DA</b>	1320	4810	3090	3.44-45
1.06	38795	1.61	II	08	<b>3D16DA</b>	1656	4810	3930	3.44-45
		1.97	II	08	<b>3D17DA</b>	1656	4810	3930	3.44-45
		2.43	III	08	<b>3E17DA</b>	1656	5170	4110	3.44-45
0.894	46000	1.37	I	08	<b>3D16DA</b>	1957	4810	3930	3.44-45
		1.67	II	08	<b>3D17DA</b>	1957	4810	3930	3.44-45
		2.05	III	08	<b>3E17DA</b>	1957	5170	4110	3.44-45
0.770	53400	1.18	I	08	<b>3D16DA</b>	2272	4810	3930	3.44-45
		1.44	II	08	<b>3D17DA</b>	2272	4810	3930	3.44-45
		1.77	II	08	<b>3E17DA</b>	2272	5170	4110	3.44-45
0.684	60120	1.05	I	08	<b>3D16DA</b>	2559	4810	3930	3.44-45
		1.28	I	08	<b>3D17DA</b>	2559	4810	3930	3.44-45
		1.57	II	08	<b>3E17DA</b>	2559	5170	4110	3.44-45
0.594	69230	1.36	I	08	<b>3E17DA</b>	2944	5170	4110	3.44-45
0.498	82580	1.14	I	08	<b>3E17DA</b>	3511	5170	4110	3.44-45

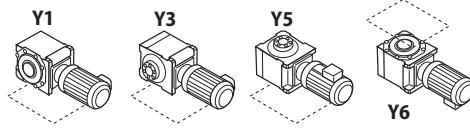
Gearmotors

**Selection  
Tables**



# Gearmotor Selection Tables 60 Hz, 1750 RPM

## Horizontal Motor Shaft Y1, Y3, Y5, Y6 Mounting Positions



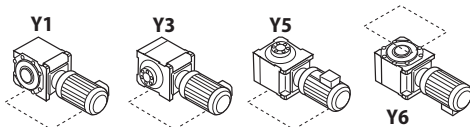
### 1 HP

Output Speed RPM	Output Torque in•lb	Service Factor		SELECTION			Overhung Load (lbs)		Dimension Page LHYM
		SF	AGMA Class	HP Symbol	Frame Size	Ratio	Hollow Shaft	Solid Shaft	
19.9	2913	1.70	II	1	<b>3A100</b>	88	1120	990	3.38-39
		2.24	III	1	<b>3A105</b>	88	1120	990	3.38-39
17.2	3371	1.62	II	1	<b>3A100</b>	102	1120	990	3.38-39
		2.13	III	1	<b>3A105</b>	102	1120	990	3.38-39
14.2	4083	1.31	I	1	<b>3A100</b>	123	1120	990	3.38-39
		1.61	II	1	<b>3A105</b>	123	1120	990	3.38-39
		2.01	III	1	<b>3A110</b>	123	1120	990	3.38-39
11.6	5000	1.05	I	1	<b>3A100</b>	151	1120	990	3.38-39
		1.45	II	1	<b>3A105</b>	151	1120	990	3.38-39
		2.56	III	1	<b>3B120</b>	151	2070	1640	3.38-39
9.78	5928	1.04	I	1	<b>3A105</b>	179	1120	990	3.38-39
		1.49	II	1	<b>3A115</b>	179	1120	990	3.38-39
		2.31	III	1	<b>3B120</b>	179	2070	1640	3.38-39
8.45	6861	1.15	I	1	<b>3A110</b>	207	1120	990	3.38-39
		1.74	II	1	<b>3B120</b>	207	2070	1640	3.38-39
		2.17	III	1	<b>3B125</b>	207	2070	1640	3.38-39
7.03	8243	1.02	I	1	<b>3A115</b>	249	1120	990	3.38-39
		1.61	II	1	<b>3B125</b>	249	2070	1640	3.38-39
		2.28	III	1	<b>3B145</b>	249	2070	1640	3.38-39
5.74	10101	1.27	I	1	<b>3B120</b>	305	2070	1640	3.38-39
		1.52	II	1	<b>3B125</b>	305	2070	1640	3.38-39
		1.86	II	1	<b>3B145</b>	305	2070	1640	3.38-39
4.81	11400	1.65	II	1	<b>3B12DB</b>	364	2070	1640	3.42-43
		1.98	II	1	<b>3B14DB</b>	364	2070	1640	3.42-43
		2.14	III	1	<b>3C14DB</b>	364	3480	2850	3.42-43
4.13	13275	1.40	II	1	<b>3B12DB</b>	424	2070	1640	3.42-43
		1.70	II	1	<b>3B14DB</b>	424	2070	1640	3.42-43
		2.14	III	1	<b>3C14DB</b>	424	3480	2850	3.42-43
3.50	15710	1.20	I	1	<b>3B12DB</b>	501	2070	1640	3.42-43
		1.44	II	1	<b>3B14DB</b>	501	2070	1640	3.42-43
		2.14	III	1	<b>3C14DB</b>	501	3480	2850	3.42-43
3.03	18100	1.04	I	1	<b>3B12DB</b>	578	2070	1640	3.42-43
		1.25	I	1	<b>3B14DB</b>	578	2070	1640	3.42-43
		2.14	III	1	<b>3C14DB</b>	578	3480	2850	3.42-43
2.56	21410	1.90	II	1	<b>3C14DB</b>	683	3480	2850	3.42-43
		2.12	III	1	<b>3C16DA</b>	683	3480	2850	3.42-43
		2.14	III	1	<b>3D16DA</b>	683	4810	3930	3.44-45
2.16	25380	1.58	II	1	<b>3C14DB</b>	809	3480	2850	3.42-43
		2.14	III	1	<b>3D16DA</b>	809	4810	3930	3.44-45
1.83	29960	1.34	I	1	<b>3C14DB</b>	956	3480	2850	3.42-43
		1.51	II	1	<b>3C16DA</b>	956	3480	2850	3.42-43
		2.10	III	1	<b>3D16DA</b>	956	4810	3930	3.44-45

Gearmotors

Selection Tables

# 60 Hz, 1750 RPM Gearmotor Selection Tables



## Horizontal Motor Shaft Y1, Y3, Y5, Y6 Mounting Positions

**1 HP**

Output Speed RPM	Output Torque in•lb	Service Factor		SELECTION			Overhung Load (lbs)		Dimension Page LHYM
		SF	AGMA Class	HP Symbol	Frame Size	Ratio	Hollow Shaft	Solid Shaft	
1.57	34925	1.17	I	1	<b>3C14DB</b>	1117	3480	2850	3.42-43
		1.29	I	1	<b>3C16DA</b>	1117	3480	2850	3.42-43
		1.80	II	1	<b>3D16DA</b>	1117	4810	3930	3.44-45
		2.14	III	1	<b>3D17DA</b>	1117	4810	3930	3.44-45
1.33	41225	1.52	II	1	<b>3D16DA</b>	1320	4810	3930	3.44-45
		1.86	II	1	<b>3D17DA</b>	1320	4810	3930	3.44-45
		2.14	III	1	<b>3E17DA</b>	1320	5170	4110	3.44-45
1.06	51725	1.21	I	1	<b>3D16DA</b>	1656	4810	3930	3.44-45
		1.82	II	1	<b>3E17DA</b>	1656	5170	4110	3.44-45
0.894	61330	1.03	I	1	<b>3D16DA</b>	1957	4810	3930	3.44-45
		1.25	I	1	<b>3D17DA</b>	1957	4810	3930	3.44-45
0.770	71210	1.33	I	1	<b>3E17DA</b>	2272	5170	4110	3.44-45
0.684	80160	1.18	I	1	<b>3E17DA</b>	2559	5170	4110	3.44-45

Gearmotors

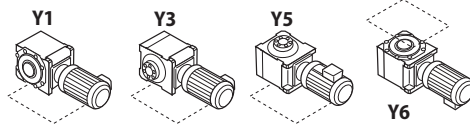
Selection Tables

**1.5 HP**

Output Speed RPM	Output Torque in•lb	Service Factor		SELECTION			Overhung Load (lbs)		Dimension Page LHYM
		SF	AGMA Class	HP Symbol	Frame Size	Ratio	Hollow Shaft	Solid Shaft	
159	547	2.10	III	1H	<b>3A100</b>	11	1120	990	3.38-39
97.2	895	2.10	III	1H	<b>3A100</b>	18	1120	990	3.38-39
83.3	1044	2.10	III	1H	<b>3A100</b>	21	1120	990	3.38-39
62.5	1390	2.10	III	1H	<b>3A100</b>	28	1120	990	3.38-39
44.9	1937	2.10	III	1H	<b>3A100</b>	39	1120	990	3.38-39
38.0	2290	2.10	III	1H	<b>3A100</b>	46	1120	990	3.38-39
33.0	2635	2.10	III	1H	<b>3A100</b>	53	1120	990	3.38-39
29.2	2980	1.78	II	1H	<b>3A100</b>	60	1120	990	3.38-39
		2.20	III	1H	<b>3A105</b>	60	1120	990	3.38-39
23.6	3685	1.73	II	1H	<b>3A100</b>	74	1120	990	3.38-39
		2.09	III	1H	<b>3A105</b>	74	1120	990	3.38-39
19.9	4370	1.13	I	1H	<b>3A100</b>	88	1120	990	3.38-39
		1.49	II	1H	<b>3A105</b>	88	1120	990	3.38-39
		2.17	III	1H	<b>3A125</b>	88	1120	990	3.38-39
17.2	5055	1.08	I	1H	<b>3A100</b>	102	1120	990	3.38-39
		1.42	II	1H	<b>3A105</b>	102	1120	990	3.38-39
		2.67	III	1H	<b>3B120</b>	102	2070	1640	3.38-39
14.2	6125	1.07	I	1H	<b>3A105</b>	123	1120	990	3.38-39
		1.55	II	1H	<b>3A115</b>	123	1120	990	3.38-39
		2.23	III	1H	<b>3B120</b>	123	2070	1640	3.38-39
11.6	7500	1.16	I	1H	<b>3A110</b>	151	1120	990	3.38-39
		1.71	II	1H	<b>3B120</b>	151	2070	1640	3.38-39
		2.13	III	1H	<b>3B125</b>	151	2070	1640	3.38-39

# Gearmotor Selection Tables 60 Hz, 1750 RPM

## Horizontal Motor Shaft Y1, Y3, Y5, Y6 Mounting Positions

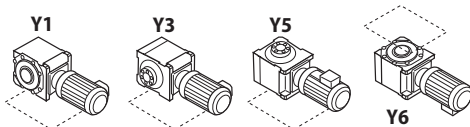


### 1.5 HP

Output Speed RPM	Output Torque in•lb	Service Factor		SELECTION			Overhung Load (lbs)		Dimension Page LHYM
		SF	AGMA Class	HP Symbol	Frame Size	Ratio	Hollow Shaft	Solid Shaft	
9.78	8890	1.07	I	1H	<b>3A125</b>	179	1120	990	3.38-39
		1.54	II	1H	<b>3B120</b>	179	2070	1640	3.38-39
		2.04	III	1H	<b>3B125</b>	179	2070	1640	3.38-39
8.45	10295	1.16	I	1H	<b>3B120</b>	207	2070	1640	3.38-39
		1.45	II	1H	<b>3B125</b>	207	2070	1640	3.38-39
		2.65	III	1H	<b>3C140</b>	207	3480	2850	3.40-41
7.03	12370	1.07	I	1H	<b>3B125</b>	249	2070	1640	3.38-39
		1.52	II	1H	<b>3B145</b>	249	2070	1640	3.38-39
		2.17	III	1H	<b>3C140</b>	249	3480	2850	3.40-41
5.74	15150	1.01	I	1H	<b>3B125</b>	305	2070	1640	3.38-39
		1.24	I	1H	<b>3B145</b>	305	2070	1640	3.38-39
		1.77	II	1H	<b>3C140</b>	305	3480	2850	3.40-41
		2.22	III	1H	<b>3C145</b>	305	3480	2850	3.40-41
4.81	17100	1.10	I	1H	<b>3B12DB</b>	364	2070	1640	3.42-43
		1.32	I	1H	<b>3B14DB</b>	364	2070	1640	3.42-43
		1.43	II	1H	<b>3C14DB</b>	364	3480	2850	3.42-43
		2.40	III	1H	<b>3C14DC</b>	364	3480	2850	3.42-43
4.13	19910	1.43	II	1H	<b>3C14DB</b>	424	3480	2850	3.42-43
		1.95	II	1H	<b>3C14DC</b>	424	3480	2850	3.42-43
		2.27	III	1H	<b>3C16DB</b>	424	3480	2850	3.42-43
3.50	23560	1.43	II	1H	<b>3C14DB</b>	501	3480	2850	3.42-43
		1.92	II	1H	<b>3C16DB</b>	501	3480	2850	3.42-43
		2.67	III	1H	<b>3D16DB</b>	501	4810	3930	3.44-45
3.03	27140	1.43	II	1H	<b>3C14DB</b>	578	3480	2850	3.42-43
		1.67	II	1H	<b>3C16DB</b>	578	3480	2850	3.42-43
		2.32	III	1H	<b>3D16DB</b>	578	4810	3930	3.44-45
2.56	32125	1.27	I	1H	<b>3C14DB</b>	683	3480	2850	3.42-43
		1.43	II	1H	<b>3D16DA</b>	683	4810	3930	3.44-45
		1.96	III	1H	<b>3D16DB</b>	683	4810	3930	3.44-45
		2.39	III	1H	<b>3D17DB</b>	683	4810	3930	3.44-45
2.16	38075	1.05	I	1H	<b>3C14DB</b>	809	3480	2850	3.42-43
		1.19	I	1H	<b>3C16DA</b>	809	3480	2850	3.42-43
		1.43	II	1H	<b>3D16DA</b>	809	4810	3930	3.44-45
		2.02	III	1H	<b>3D17DB</b>	809	4810	3930	3.44-45
		2.48	III	1H	<b>3E17DB</b>	809	5170	4110	3.44-45
1.83	44940	1.40	II	1H	<b>3D16DA</b>	956	4810	3930	3.44-45
		1.43	II	1H	<b>3D17DA</b>	956	4810	3930	3.44-45
		2.10	III	1H	<b>3E17DB</b>	956	5170	4110	3.44-45
1.57	52385	1.20	I	1H	<b>3D16DA</b>	1117	4810	3930	3.44-45
		1.43	II	1H	<b>3D17DA</b>	1117	4810	3930	3.44-45
1.33	61840	1.01	I	1H	<b>3D16DA</b>	1320	4810	3930	3.44-45
		1.24	I	1H	<b>3D17DA</b>	1320	4810	3930	3.44-45
1.06	77590	1.21	I	1H	<b>3E17DA</b>	1656	5170	4110	3.44-45
0.894	92000	1.03	I	1H	<b>3E17DA</b>	1957	5170	4110	3.44-45

Gearmotors  
Selection  
Tables

# 60 Hz, 1750 RPM Gearmotor Selection Tables



## Horizontal Motor Shaft Y1, Y3, Y5, Y6 Mounting Positions

**2 HP**

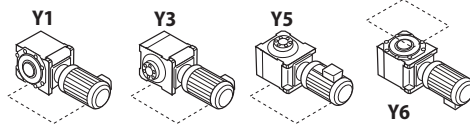
Output Speed RPM	Output Torque in•lb	Service Factor		SELECTION			Overhung Load (lbs)		Dimension Page LHYM
		SF	AGMA Class	HP Symbol	Frame Size	Ratio	Hollow Shaft	Solid Shaft	
159	730	1.58	II	2	<b>3A100</b>	11	1120	990	3.38-39
		2.13	III	2	<b>3A105</b>	11	1120	990	3.38-39
97.2	1190	1.58	II	2	<b>3A100</b>	18	1120	990	3.38-39
		2.13	III	2	<b>3A105</b>	18	1120	990	3.38-39
83.3	1390	1.58	II	2	<b>3A100</b>	21	1120	990	3.38-39
		2.13	III	2	<b>3A105</b>	21	1120	990	3.38-39
62.5	1855	1.58	II	2	<b>3A100</b>	28	1120	990	3.38-39
		2.13	III	2	<b>3A105</b>	28	1120	990	3.38-39
45.0	2580	1.58	II	2	<b>3A100</b>	39	1120	990	3.38-39
		2.13	III	2	<b>3A105</b>	39	1120	990	3.38-39
38.0	3050	1.58	II	2	<b>3A100</b>	46	1120	990	3.38-39
		2.13	III	2	<b>3A105</b>	46	1120	990	3.38-39
33.0	3515	1.58	II	2	<b>3A100</b>	53	1120	990	3.38-39
		2.13	III	2	<b>3A105</b>	53	1120	990	3.38-39
29.2	3970	1.34	I	2	<b>3A100</b>	60	1120	990	3.38-39
		1.65	II	2	<b>3A105</b>	60	1120	990	3.38-39
		2.13	III	2	<b>3A110</b>	60	1120	990	3.38-39
23.6	4910	1.30	I	2	<b>3A100</b>	74	1120	990	3.38-39
		1.57	II	2	<b>3A105</b>	74	1120	990	3.38-39
		2.66	III	2	<b>3B120</b>	74	2070	1640	3.38-39
19.9	5830	1.12	I	2	<b>3A105</b>	88	1120	990	3.38-39
		1.49	II	2	<b>3A115</b>	88	1120	990	3.38-39
		2.07	III	2	<b>3B120</b>	88	2070	1640	3.38-39
17.2	6740	1.07	I	2	<b>3A105</b>	102	1120	990	3.38-39
		1.41	II	2	<b>3A115</b>	102	1120	990	3.38-39
		2.01	III	2	<b>3B120</b>	102	2070	1640	3.38-39
14.2	8165	1.01	I	2	<b>3A110</b>	123	1120	990	3.38-39
		1.67	II	2	<b>3B120</b>	123	2070	1640	3.38-39
		2.13	III	2	<b>3B125</b>	123	2070	1640	3.38-39
11.6	10000	1.28	I	2	<b>3B120</b>	151	2070	1640	3.38-39
		1.60	II	2	<b>3B125</b>	151	2070	1640	3.38-39
		2.64	III	2	<b>3C140</b>	151	3480	2850	3.38-39
9.78	11860	1.16	I	2	<b>3B120</b>	179	2070	1640	3.38-39
		1.53	II	2	<b>3B125</b>	179	2070	1640	3.38-39
		2.30	III	2	<b>3C140</b>	179	3480	2850	3.40-41
8.45	13725	1.09	I	2	<b>3B125</b>	207	2070	1640	3.38-39
		1.99	II	2	<b>3C140</b>	207	3480	2850	3.40-41
		2.45	III	2	<b>3C145</b>	207	3480	2850	3.40-41
7.03	16495	1.14	I	2	<b>3B145</b>	249	2070	1640	3.38-39
		1.63	II	2	<b>3C140</b>	249	3480	2850	3.40-41
		2.03	III	2	<b>3C145</b>	249	3480	2850	3.40-41
5.74	20200	1.33	I	2	<b>3C140</b>	305	3480	2850	3.40-41
		1.67	II	2	<b>3C145</b>	305	3480	2850	3.40-41
		2.33	III	2	<b>3D160</b>	305	4810	3930	3.40-41

Gearmotors

Selection Tables

# Gearmotor Selection Tables 60 Hz, 1750 RPM

## Horizontal Motor Shaft Y1, Y3, Y5, Y6 Mounting Positions



### 2 HP

Output Speed RPM	Output Torque in•lb	Service Factor		SELECTION			Overhung Load (lbs)		Dimension Page LHYM
		SF	AGMA Class	HP Symbol	Frame Size	Ratio	Hollow Shaft	Solid Shaft	
4.81	22800	1.07	I	2	<b>3C14DB</b>	364	3480	2850	3.42-43
		1.80	II	2	<b>3C14DC</b>	364	3480	2850	3.42-43
		1.99	II	2	<b>3C16DB</b>	364	3480	2850	3.42-43
		2.25	III	2	<b>3D16DB</b>	364	4810	3930	3.44-45
4.13	26550	1.07	I	2	<b>3C14DB</b>	424	3480	2850	3.42-43
		1.71	II	2	<b>3C16DB</b>	424	3480	2850	3.42-43
		2.25	III	2	<b>3D16DB</b>	424	4810	3930	3.44-45
3.50	31420	1.07	I	2	<b>3C14DB</b>	501	3480	2850	3.42-43
		1.44	II	2	<b>3C16DB</b>	501	3480	2850	3.42-43
		2.01	III	2	<b>3D16DB</b>	501	4810	3930	3.44-45
3.03	36190	1.07	I	2	<b>3C14DB</b>	578	3480	2850	3.42-43
		1.25	I	2	<b>3C16DB</b>	578	3480	2850	3.42-43
		1.74	II	2	<b>3D16DB</b>	578	4810	3930	3.44-45
		2.12	III	2	<b>3D17DB</b>	578	4810	3930	3.44-45
2.56	42835	1.07	I	2	<b>3D16DA</b>	683	4810	3930	3.44-45
		1.80	II	2	<b>3D17DB</b>	683	4810	3930	3.44-45
		2.21	III	2	<b>3E17DB</b>	683	5170	4110	3.44-45
2.16	50770	1.07	I	2	<b>3D16DA</b>	809	4810	3930	3.44-45
		1.86	II	2	<b>3E17DB</b>	809	5170	4110	3.44-45
1.83	59925	1.05	I	2	<b>3D16DA</b>	956	4810	3930	3.44-45
		1.07	I	2	<b>3D17DA</b>	956	4810	3930	3.44-45
		1.58	II	2	<b>3E17DB</b>	956	5170	4110	3.44-45
1.57	69850	1.07	I	2	<b>3D17DA</b>	1117	4810	3930	3.44-45
1.33	82450	1.07	I	2	<b>3E17DA</b>	1320	5170	4110	3.44-45

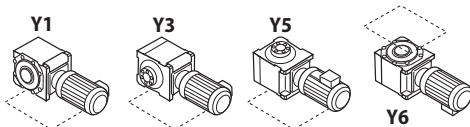
Gearmotors

Selection Tables

### 3 HP

Output Speed RPM	Output Torque in•lb	Service Factor		SELECTION			Overhung Load (lbs)		Dimension Page LHYM
		SF	AGMA Class	HP Symbol	Frame Size	Ratio	Hollow Shaft	Solid Shaft	
159	1095	1.05	I	3	<b>3A100</b>	11	1120	990	3.38-39
		1.42	II	3	<b>3A105</b>	11	1120	990	3.38-39
		2.27	III	3	<b>3A120</b>	11	1120	990	3.38-39
97.2	1790	1.11	I	3	<b>3A100</b>	18	1120	990	3.38-39
		1.42	II	3	<b>3A105</b>	18	1120	990	3.38-39
		2.27	III	3	<b>3A120</b>	18	1120	990	3.38-39
83.3	2090	1.05	I	3	<b>3A100</b>	21	1120	990	3.38-39
		1.42	II	3	<b>3A105</b>	21	1120	990	3.38-39
		1.59	II	3	<b>3A110</b>	21	1120	990	3.38-39
		2.27	III	3	<b>3A120</b>	21	1120	990	3.38-39
62.5	2780	1.05	I	3	<b>3A100</b>	28	1120	990	3.38-39
		1.42	II	3	<b>3A105</b>	28	1120	990	3.38-39
		1.59	II	3	<b>3A110</b>	28	1120	990	3.38-39
		2.27	III	3	<b>3A120</b>	28	1120	990	3.38-39

# 60 Hz, 1750 RPM Gearmotor Selection Tables



## Horizontal Motor Shaft Y1, Y3, Y5, Y6 Mounting Positions

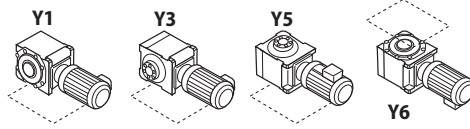
**3 HP**

Output Speed RPM	Output Torque in•lb	Service Factor		SELECTION			Overhung Load (lbs)		Dimension Page LHYM
		SF	AGMA Class	HP Symbol	Frame Size	Ratio	Hollow Shaft	Solid Shaft	
44.9	3875	1.05	I	3	<b>3A100</b>	39	1120	990	3.38-39
		1.42	II	3	<b>3A105</b>	39	1120	990	3.38-39
		1.59	II	3	<b>3A110</b>	39	1120	990	3.38-39
		2.27	III	3	<b>3A120</b>	39	1120	990	3.38-39
38.0	4575	1.05	I	3	<b>3A100</b>	46	1120	990	3.38-39
		1.42	II	3	<b>3A105</b>	46	1120	990	3.38-39
		1.59	II	3	<b>3A110</b>	46	1120	990	3.38-39
		2.09	III	3	<b>3A125</b>	46	1120	990	3.38-39
33.0	5270	1.05	I	3	<b>3A100</b>	53	1120	990	3.38-39
		1.42	II	3	<b>3A105</b>	53	1120	990	3.38-39
		1.59	II	3	<b>3A110</b>	53	1120	990	3.38-39
		2.27	III	3	<b>3B120</b>	53	2070	1640	3.38-39
29.2	5955	1.10	I	3	<b>3A105</b>	60	1120	990	3.38-39
		1.42	II	3	<b>3A110</b>	60	1120	990	3.38-39
		1.60	II	3	<b>3A115</b>	60	1120	990	3.38-39
		2.27	III	3	<b>3B120</b>	60	2070	1640	3.38-39
23.6	7370	1.05	I	3	<b>3A105</b>	74	1120	990	3.38-39
		1.77	II	3	<b>3B120</b>	74	2070	1640	3.38-39
		2.18	III	3	<b>3B125</b>	74	2070	1640	3.38-39
19.9	8740	1.09	I	3	<b>3A125</b>	88	1120	990	3.38-39
		1.77	II	3	<b>3B125</b>	88	2070	1640	3.38-39
		2.16	III	3	<b>3B145</b>	88	2070	1640	3.38-39
17.2	10110	1.34	I	3	<b>3B120</b>	102	2070	1640	3.38-39
		1.69	II	3	<b>3B125</b>	102	2070	1640	3.38-39
		2.66	III	3	<b>3C140</b>	102	3480	2850	3.40-41
14.2	12250	1.11	I	3	<b>3B120</b>	123	2070	1640	3.38-39
		1.42	II	3	<b>3B125</b>	123	2070	1640	3.38-39
		2.33	III	3	<b>3C140</b>	123	3480	2850	3.40-41
11.6	14995	1.06	I	3	<b>3B125</b>	151	2070	1640	3.38-39
		1.76	II	3	<b>3C140</b>	151	3480	2850	3.40-41
		2.41	III	3	<b>3C145</b>	151	3480	2850	3.40-41
9.78	17785	1.02	I	3	<b>3B125</b>	179	2070	1640	3.38-39
		1.06	I	3	<b>3B145</b>	179	2070	1640	3.38-39
		1.53	II	3	<b>3C140</b>	179	3480	2850	3.40-41
		1.89	II	3	<b>3C145</b>	179	3480	2850	3.40-41
		2.12	III	3	<b>3C165</b>	179	3480	2850	3.40-41
8.45	20585	1.32	I	3	<b>3C140</b>	207	3480	2850	3.40-41
		1.63	II	3	<b>3C145</b>	207	3480	2850	3.40-41
		2.57	III	3	<b>3D165</b>	207	4810	3930	3.40-41
7.03	24740	1.09	I	3	<b>3C140</b>	249	3480	2850	3.40-41
		1.52	II	3	<b>3C165</b>	249	3480	2850	3.40-41
		2.53	III	3	<b>3D165</b>	249	4810	3930	3.40-41

Gearmotors  
Selection  
Tables

# Gearmotor Selection Tables 60 Hz, 1750 RPM

## Horizontal Motor Shaft Y1, Y3, Y5, Y6 Mounting Positions



### 3 HP

Output Speed RPM	Output Torque in•lb	Service Factor		SELECTION			Overhung Load (lbs)		Dimension Page LHYM
		SF	AGMA Class	HP Symbol	Frame Size	Ratio	Hollow Shaft	Solid Shaft	
5.74	30300	1.11	I	3	<b>3C145</b>	305	3480	2850	3.40-41
		1.55	II	3	<b>3D160</b>	305	4810	3930	3.40-41
		2.11	III	3	<b>3D175</b>	305	4810	3930	3.40-41
4.81	34200	1.20	I	3	<b>3C14DC</b>	364	3480	2850	3.42-43
		1.50	II	3	<b>3D16DB</b>	364	4810	3930	3.44-45
		2.24	III	3	<b>3D17DC</b>	364	4810	3930	3.44-45
4.13	39830	0.97	-	3	<b>3C14DC</b>	424	3480	2850	3.42-43
		1.50	II	3	<b>3D16DB</b>	424	4810	3930	3.44-45
		1.93	II	3	<b>3D17DC</b>	424	4810	3930	3.44-45
		2.37	III	3	<b>3E17DC</b>	424	5170	4110	3.44-45
3.50	47130	0.96	-	3	<b>3C16DB</b>	501	3480	2850	3.42-43
		1.34	I	3	<b>3D16DB</b>	501	4810	3930	3.44-45
		1.50	II	3	<b>3D17DB</b>	501	4810	3930	3.44-45
		2.00	III	3	<b>3E17DC</b>	501	5170	4110	3.44-45
3.03	54285	1.16	I	3	<b>3D16DB</b>	578	4810	3930	3.44-45
		1.41	II	3	<b>3D17DB</b>	578	4810	3930	3.44-45
		1.50	II	3	<b>3E17DB</b>	578	5170	4110	3.44-45
2.56	64255	0.98	-	3	<b>3D16DB</b>	683	4810	3930	3.44-45
		1.20	I	3	<b>3D17DB</b>	683	4810	3930	3.44-45
2.16	76155	1.01	I	3	<b>3D17DB</b>	809	4810	3930	3.44-45
		1.24	I	3	<b>3E17DB</b>	809	5170	4110	3.44-45
1.83	89885	1.05	I	3	<b>3E17DB</b>	956	5170	4110	3.44-45

Gearmotors

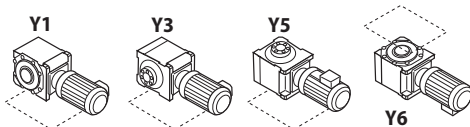
Selection Tables

### 5 HP

Output Speed RPM	Output Torque in•lb	Service Factor		SELECTION			Overhung Load (lbs)		Dimension Page LHYM
		SF	AGMA Class	HP Symbol	Frame Size	Ratio	Hollow Shaft	Solid Shaft	
159	1820	1.36	I	5	<b>3A120</b>	11	1120	990	3.38-39
		1.56	II	5	<b>3A125</b>	11	1120	990	3.38-39
97.2	2980	1.36	I	5	<b>3A120</b>	18	1120	990	3.38-39
		1.56	II	5	<b>3A125</b>	18	1120	990	3.38-39
		2.96	III	5	<b>3A145</b>	18	1120	990	3.38-39
83.3	3480	1.05	I	5	<b>3A115</b>	21	1120	990	3.38-39
		1.56	II	5	<b>3A125</b>	21	1120	990	3.38-39
		2.46	III	5	<b>3A145</b>	21	1120	990	3.38-39
62.5	4635	1.05	I	5	<b>3A115</b>	28	1120	990	3.38-39
		1.86	II	5	<b>3A125</b>	28	1120	990	3.38-39
		2.02	III	5	<b>3A145</b>	28	1120	990	3.38-39
44.9	6455	1.05	I	5	<b>3A115</b>	39	1120	990	3.38-39
		1.36	I	5	<b>3A120</b>	39	1120	990	3.38-39
		1.48	II	5	<b>3A125</b>	39	1120	990	3.38-39
		2.94	III	5	<b>3B145</b>	39	2070	1640	3.38-39



# 60 Hz, 1750 RPM Gearmotor Selection Tables



## Horizontal Motor Shaft Y1, Y3, Y5, Y6 Mounting Positions

**5 HP**

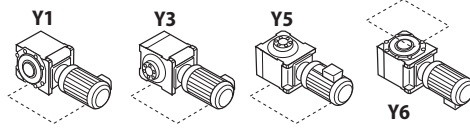
Output Speed RPM	Output Torque in•lb	Service Factor		SELECTION			Overhung Load (lbs)		Dimension Page LHYM
		SF	AGMA Class	HP Symbol	Frame Size	Ratio	Hollow Shaft	Solid Shaft	
38.0	7630	1.05	I	5	<b>3A115</b>	46	1120	990	3.38-39
		1.36	I	5	<b>3B120</b>	46	2070	1640	3.38-39
		1.59	II	5	<b>3B125</b>	46	2070	1640	3.38-39
		2.50	III	5	<b>3B145</b>	46	2070	1640	3.38-39
33.0	8785	1.05	I	5	<b>3A115</b>	53	1120	990	3.38-39
		1.59	II	5	<b>3B125</b>	53	2070	1640	3.38-39
		2.16	III	5	<b>3B145</b>	53	2070	1640	3.38-39
29.2	9930	1.36	I	5	<b>3B120</b>	60	2070	1640	3.38-39
		1.52	II	5	<b>3B125</b>	60	2070	1640	3.38-39
		2.70	III	5	<b>3C140</b>	60	3480	2850	3.40-41
23.6	12285	1.06	I	5	<b>3B120</b>	74	2070	1640	3.38-39
		1.54	II	5	<b>3B145</b>	74	2070	1640	3.38-39
		2.32	III	5	<b>3C140</b>	74	3480	2850	3.40-41
19.9	14570	1.06	I	5	<b>3B125</b>	88	2070	1640	3.38-39
		1.85	II	5	<b>3C140</b>	88	3480	2850	3.40-41
		2.12	III	5	<b>3C145</b>	88	3480	2850	3.40-41
17.2	16855	1.01	I	5	<b>3B125</b>	102	2070	1640	3.38-39
		1.12	I	5	<b>3B145</b>	102	2070	1640	3.38-39
		1.60	II	5	<b>3C140</b>	102	3480	2850	3.40-41
		2.02	III	5	<b>3C145</b>	102	3480	2850	3.40-41
14.2	20415	1.40	I	5	<b>3C140</b>	123	3480	2850	3.40-41
		1.85	II	5	<b>3C145</b>	123	3480	2850	3.40-41
		2.60	III	5	<b>3D160</b>	123	4810	3930	3.40-41
11.6	24990	1.06	I	5	<b>3C140</b>	151	3480	2850	3.40-41
		1.45	II	5	<b>3C145</b>	151	3480	2850	3.40-41
		2.00	III	5	<b>3D160</b>	151	4810	3930	3.40-41
9.78	29640	1.13	I	5	<b>3C145</b>	179	3480	2850	3.40-41
		1.54	II	5	<b>3D160</b>	179	4810	3930	3.40-41
		2.02	III	5	<b>3D165</b>	179	4810	3930	3.40-41
8.45	34310	1.10	I	5	<b>3C165</b>	207	3480	2850	3.40-41
		1.54	II	5	<b>3D165</b>	207	4810	3930	3.40-41
		2.22	III	5	<b>3E175</b>	207	5170	4110	3.40-41
7.03	41240	1.52	II	5	<b>3D165</b>	249	4810	3930	3.40-41
		1.92	II	5	<b>3E175</b>	249	5170	4110	3.40-41
5.74	50510	1.05	I	5	<b>3D165</b>	305	4810	3930	3.40-41
		1.51	II	5	<b>3E175</b>	305	5170	4110	3.40-41
4.81	57000	1.10	I	5	<b>3D16DC</b>	364	4810	3930	3.44-45
		1.35	I	5	<b>3D17DC</b>	364	4810	3930	3.44-45
		1.65	II	5	<b>3E17DC</b>	364	5170	4110	3.44-45
4.13	66380	1.16	I	5	<b>3D17DC</b>	424	4810	3930	3.44-45
		1.42	II	5	<b>3E17DC</b>	424	5170	4110	3.44-45
3.49	78550	0.98	-	5	<b>3D17DC</b>	501	4810	3930	3.44-45
		1.20	I	5	<b>3E17DC</b>	501	5170	4110	3.44-45
3.03	90480	1.04	I	5	<b>3E17DC</b>	578	5170	4110	3.44-45

Gearmotors

Selection Tables

# Gearmotor Selection Tables 60 Hz, 1750 RPM

## Horizontal Motor Shaft Y1, Y3, Y5, Y6 Mounting Positions



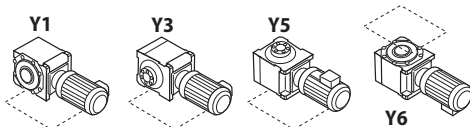
### 7.5 HP

Output Speed RPM	Output Torque in•lb	Service Factor		SELECTION			Overhung Load (lbs)		Dimension Page LHYM
		SF	AGMA Class	HP Symbol	Frame Size	Ratio	Hollow Shaft	Solid Shaft	
159	2735	1.04	I	8	<b>3A125</b>	11	1120	990	3.38-39
		2.32	III	8	<b>3A140</b>	11	1120	990	3.38-39
97.2	4475	1.04	I	8	<b>3A125</b>	18	1120	990	3.38-39
		1.97	II	8	<b>3A145</b>	18	1120	990	3.38-39
		2.32	III	8	<b>3B140</b>	18	2070	1640	3.38-39
		1.04	I	8	<b>3A125</b>	21	1120	990	3.38-39
83.3	5220	1.64	II	8	<b>3A145</b>	21	1120	990	3.38-39
		2.32	III	8	<b>3B140</b>	21	2070	1640	3.38-39
62.5	6960	1.24	I	8	<b>3A125</b>	28	1120	990	3.38-39
		1.35	I	8	<b>3A145</b>	28	1120	990	3.38-39
		2.32	III	8	<b>3B140</b>	28	2070	1640	3.38-39
		1.06	I	8	<b>3B125</b>	39	2070	1640	3.38-39
44.9	9685	1.96	II	8	<b>3B145</b>	39	2070	1640	3.38-39
		2.32	III	8	<b>3C140</b>	39	3480	2850	3.40-41
38.0	11445	1.06	I	8	<b>3B125</b>	46	2070	1640	3.38-39
		1.67	II	8	<b>3B145</b>	46	2070	1640	3.38-39
		2.32	III	8	<b>3C140</b>	46	3480	2850	3.40-41
		1.06	I	8	<b>3B125</b>	53	2070	1640	3.38-39
33.0	13175	1.44	II	8	<b>3B145</b>	53	2070	1640	3.38-39
		2.15	III	8	<b>3C140</b>	53	3480	2850	3.40-41
29.2	14890	1.01	I	8	<b>3B125</b>	60	2070	1640	3.38-39
		1.80	II	8	<b>3C140</b>	60	3480	2850	3.40-41
		2.15	III	8	<b>3C145</b>	60	3480	2850	3.40-41
		1.03	I	8	<b>3B145</b>	74	2070	1640	3.38-39
23.6	18425	1.55	II	8	<b>3C140</b>	74	3480	2850	3.40-41
		1.97	II	8	<b>3C145</b>	74	3480	2850	3.40-41
		2.05	III	8	<b>3C165</b>	74	3480	2850	3.40-41
		1.23	I	8	<b>3C140</b>	88	3480	2850	3.40-41
19.9	21850	1.41	II	8	<b>3C145</b>	88	3480	2850	3.40-41
		2.69	III	8	<b>3D165</b>	88	4810	3930	3.40-41
17.2	25280	1.06	I	8	<b>3C140</b>	102	3480	2850	3.40-41
		1.35	I	8	<b>3C145</b>	102	3480	2850	3.40-41
		1.49	II	8	<b>3C165</b>	102	3480	2850	3.40-41
		2.53	III	8	<b>3D175</b>	102	4810	3930	3.40-41
14.2	30625	1.24	I	8	<b>3C145</b>	123	3480	2850	3.40-41
		1.73	II	8	<b>3D160</b>	123	4810	3930	3.40-41
		2.04	III	8	<b>3D165</b>	123	4810	3930	3.40-41
		1.01	I	8	<b>3C165</b>	151	3480	2850	3.40-41
11.6	37490	1.41	II	8	<b>3D165</b>	151	4810	3930	3.40-41
		1.71	II	8	<b>3D175</b>	151	4810	3930	3.40-41
		2.03	III	8	<b>3E175</b>	151	5170	4110	3.40-41

Gearmotors

Selection Tables

# 60 Hz, 1750 RPM Gearmotor Selection Tables



## Horizontal Motor Shaft Y1, Y3, Y5, Y6 Mounting Positions

**7.5 HP**

Output Speed RPM	Output Torque in•lb	Service Factor		SELECTION			Overhung Load (lbs)		Dimension Page LHYM
		SF	AGMA Class	HP Symbol	Frame Size	Ratio	Hollow Shaft	Solid Shaft	
9.78	44465	1.03	I	8	<b>3D160</b>	179	4810	3930	3.40-41
		1.44	II	8	<b>3D175</b>	179	4810	3930	3.40-41
		1.92	II	8	<b>3E175</b>	179	5170	4110	3.40-41
8.45	51465	1.03	I	8	<b>3D165</b>	207	4810	3930	3.40-41
		1.48	II	8	<b>3E175</b>	207	5170	4110	3.40-41
7.03	61860	1.01	I	8	<b>3D165</b>	249	4810	3930	3.40-41
		1.28	I	8	<b>3E175</b>	249	5170	4110	3.40-41
5.74	75760	1.01	I	8	<b>3E175</b>	305	5170	4110	3.40-41
		1.10	I	8	<b>3E17DC</b>	364	5170	4110	3.44-45

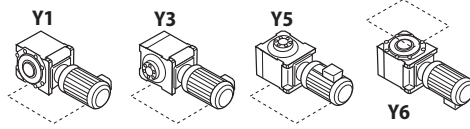
**10 HP**

Output Speed RPM	Output Torque in•lb	Service Factor		SELECTION			Overhung Load (lbs)		Dimension Page LHYM
		SF	AGMA Class	HP Symbol	Frame Size	Ratio	Hollow Shaft	Solid Shaft	
159	3645	1.74	II	10	<b>3A140</b>	11	1120	990	3.38-39
		2.02	III	10	<b>3A145</b>	11	1120	990	3.38-39
97.2	5965	1.48	II	10	<b>3A145</b>	18	1120	990	3.38-39
		1.74	II	10	<b>3B140</b>	18	2070	1640	3.38-39
		2.02	III	10	<b>3B145</b>	18	2070	1640	3.38-39
83.3	6960	1.23	I	10	<b>3A145</b>	21	1120	990	3.38-39
		1.74	II	10	<b>3B140</b>	21	2070	1640	3.38-39
		2.02	III	10	<b>3B145</b>	21	2070	1640	3.38-39
62.5	9275	1.01	I	10	<b>3A145</b>	28	1120	990	3.38-39
		1.74	II	10	<b>3B140</b>	28	2070	1640	3.38-39
		2.01	III	10	<b>3B145</b>	28	2070	1640	3.38-39
44.9	12910	1.47	II	10	<b>3B145</b>	39	2070	1640	3.38-39
		1.74	II	10	<b>3C140</b>	39	3480	2850	3.40-41
		2.02	III	10	<b>3C145</b>	39	3480	2850	3.40-41
38.0	15255	1.25	I	10	<b>3B145</b>	46	2070	1640	3.38-39
		1.74	II	10	<b>3C140</b>	46	3480	2850	3.40-41
		2.02	III	10	<b>3C145</b>	46	3480	2850	3.40-41
33.0	17570	1.08	I	10	<b>3B145</b>	53	2070	1640	3.38-39
		1.61	II	10	<b>3C140</b>	53	3480	2850	3.40-41
		2.16	III	10	<b>3C165</b>	53	3480	2850	3.40-41
29.2	19855	1.35	I	10	<b>3C140</b>	60	3480	2850	3.40-41
		1.61	II	10	<b>3C145</b>	60	3480	2850	3.40-41
		2.52	III	10	<b>3D165</b>	60	4810	3930	3.40-41
23.6	24570	1.16	I	10	<b>3C140</b>	74	3480	2820	3.40-41
		1.48	II	10	<b>3C145</b>	74	3480	2850	3.40-41
		2.16	III	10	<b>3D165</b>	74	4810	3930	3.40-41
19.9	29140	1.06	I	10	<b>3C145</b>	88	3480	2850	3.40-41
		2.02	III	10	<b>3D165</b>	88	4810	3930	3.40-41

Gearmotors  
Selection Tables

# Gearmotor Selection Tables 60 Hz, 1750 RPM

## Horizontal Motor Shaft Y1, Y3, Y5, Y6 Mounting Positions



### 10 HP

Output Speed RPM	Output Torque in•lb	Service Factor		SELECTION			Overhung Load (lbs)		Dimension Page LHYM
		SF	AGMA Class	HP Symbol	Frame Size	Ratio	Hollow Shaft	Solid Shaft	
17.2	33710	1.01	I	10	<b>3C145</b>	102	3480	2850	3.40-41
		1.41	II	10	<b>3D160</b>	102	4810	3930	3.40-41
		2.14	III	10	<b>3E175</b>	102	5170	4110	3.40-41
14.2	40830	1.30	I	10	<b>3D160</b>	123	4810	3930	3.40-41
		1.53	II	10	<b>3D165</b>	123	4810	3930	3.40-41
		2.02	III	10	<b>3E175</b>	123	5170	4110	3.40-41
11.6	49985	1.00	I	10	<b>3D160</b>	151	4810	3930	3.40-41
		1.52	II	10	<b>3E175</b>	151	5170	4110	3.40-41
9.78	59285	1.01	I	10	<b>3D165</b>	179	4810	3930	3.40-41
		1.08	I	10	<b>3D175</b>	179	4810	3930	3.40-41
		1.44	II	10	<b>3E175</b>	179	5170	4110	3.40-41
8.45	68620	1.11	I	10	<b>3E175</b>	207	5170	4110	3.40-41

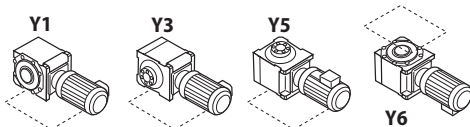
Gearmotors

Selection Tables

### 15 HP

Output Speed RPM	Output Torque in•lb	Service Factor		SELECTION			Overhung Load (lbs)		Dimension Page LHYM
		SF	AGMA Class	HP Symbol	Frame Size	Ratio	Hollow Shaft	Solid Shaft	
159	5470	1.16	I	15	<b>3A140</b>	11	1120	990	3.38-39
		1.35	I	15	<b>3A145</b>	11	1120	990	3.38-39
97.2	8950	1.16	I	15	<b>3B140</b>	18	2070	1640	3.38-39
		1.35	I	15	<b>3B145</b>	18	2070	1640	3.38-39
		1.81	II	15	<b>3B160</b>	18	2070	1640	3.38-39
83.3	10440	1.16	I	15	<b>3B140</b>	21	2070	1640	3.38-39
		1.35	I	15	<b>3B145</b>	21	2070	1640	3.38-39
		1.65	II	15	<b>3B165</b>	21	2070	1640	3.38-39
		2.15	III	15	<b>3C165</b>	21	3480	2850	3.40-41
62.5	13910	1.16	I	15	<b>3B140</b>	28	2070	1640	3.38-39
		1.76	II	15	<b>3C160</b>	28	3480	2850	3.40-41
		2.15	III	15	<b>3C165</b>	28	3480	2850	3.40-41
44.9	19370	1.16	I	15	<b>3C140</b>	39	3480	2850	3.40-41
		1.76	II	15	<b>3C160</b>	39	3480	2850	3.40-41
		2.15	III	15	<b>3D165</b>	39	4810	3930	3.40-41
38.0	22880	1.16	I	15	<b>3C140</b>	46	3480	2850	3.40-41
		1.35	I	15	<b>3C145</b>	46	3480	2850	3.40-41
		1.66	II	15	<b>3C165</b>	46	3480	2850	3.40-41
		2.02	III	15	<b>3D165</b>	46	4810	3930	3.40-41
33.0	26355	1.07	I	15	<b>3C140</b>	53	3480	2850	3.40-41
		1.31	I	15	<b>3C145</b>	53	3480	2850	3.40-41
		1.44	II	15	<b>3C165</b>	53	3480	2850	3.40-41
		2.01	III	15	<b>3D165</b>	53	4810	3930	3.40-41

# 60 Hz, 1750 RPM Gearmotor Selection Tables



## Horizontal Motor Shaft Y1, Y3, Y5, Y6 Mounting Positions

**15 HP**

Output Speed RPM	Output Torque in•lb	Service Factor		SELECTION			Overhung Load (lbs)		Dimension Page LHYM
		SF	AGMA Class	HP Symbol	Frame Size	Ratio	Hollow Shaft	Solid Shaft	
29.2	29785	1.07	I	15	<b>3C145</b>	60	3480	2850	3.40-41
		1.68	II	15	<b>3D165</b>	60	4810	3930	3.40-41
		2.15	III	15	<b>3D175</b>	60	4810	3930	3.40-41
23.6	36850	1.03	I	15	<b>3C165</b>	74	3480	2850	3.40-41
		1.44	II	15	<b>3D165</b>	74	4810	3930	3.40-41
		1.97	II	15	<b>3E175</b>	74	5170	4110	3.40-41
19.9	43700	1.35	I	15	<b>3D165</b>	88	4810	3930	3.40-41
		1.41	II	15	<b>3D170</b>	88	4810	3930	3.40-41
		1.65	II	15	<b>3E175</b>	88	5170	4110	3.40-41
17.2	50565	1.27	I	15	<b>3D175</b>	102	4810	3930	3.40-41
		1.43	II	15	<b>3E175</b>	102	5170	4110	3.40-41
14.2	61250	1.02	I	15	<b>3D165</b>	123	4810	3930	3.40-41
		1.05	I	15	<b>3D175</b>	123	4810	3930	3.40-41
		1.35	I	15	<b>3E175</b>	123	5170	4110	3.40-41
11.6	74975	1.01	I	15	<b>3E175</b>	151	5170	4110	3.40-41

Gearmotors

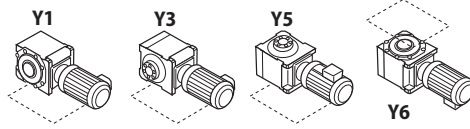
Selection Tables

**20 HP**

Output Speed RPM	Output Torque in•lb	Service Factor		SELECTION			Overhung Load (lbs)		Dimension Page LHYM
		SF	AGMA Class	HP Symbol	Frame Size	Ratio	Hollow Shaft	Solid Shaft	
159	7290	1.01	I	20	<b>3A145</b>	11	1120	990	3.38-39
		1.47	II	20	<b>3B165</b>	11	2070	1640	3.38-39
		2.01	III	20	<b>3C175</b>	11	3480	2850	3.40-41
97.2	11930	1.01	I	20	<b>3B145</b>	18	2070	1640	3.38-39
		1.48	II	20	<b>3B165</b>	18	2070	1640	3.38-39
		2.02	III	20	<b>3C175</b>	18	3480	2850	3.40-41
83.3	13920	1.01	I	20	<b>3B145</b>	21	2070	1640	3.38-39
		1.36	I	20	<b>3C160</b>	21	3480	2850	3.40-41
		1.62	II	20	<b>3C165</b>	21	3480	2850	3.40-41
		2.02	III	20	<b>3C175</b>	21	3480	2850	3.40-41
62.5	18555	1.01	I	20	<b>3B145</b>	28	2070	1640	3.38-39
		1.32	I	20	<b>3C160</b>	28	3480	2850	3.40-41
		1.62	II	20	<b>3C165</b>	28	3480	2850	3.40-41
		2.01	III	20	<b>3C175</b>	28	3480	2850	3.40-41
44.9	25825	1.01	I	20	<b>3C145</b>	39	3480	2850	3.40-41
		1.48	II	20	<b>3C165</b>	39	3480	2850	3.40-41
		1.62	II	20	<b>3D165</b>	39	4810	3930	3.40-41
		2.01	III	20	<b>3D175</b>	39	4810	3930	3.40-41
38.0	30515	1.01	I	20	<b>3C145</b>	46	3480	2850	3.40-41
		1.52	II	20	<b>3D165</b>	46	4810	3930	3.40-41
		2.01	III	20	<b>3D175</b>	46	4810	3930	3.40-41

# Gearmotor Selection Tables 60 Hz, 1750 RPM

## Horizontal Motor Shaft Y1, Y3, Y5, Y6 Mounting Positions



### 20 HP

Output Speed RPM	Output Torque in•lb	Service Factor		SELECTION			Overhung Load (lbs)		Dimension Page LHYM
		SF	AGMA Class	HP Symbol	Frame Size	Ratio	Hollow Shaft	Solid Shaft	
33.0	35140	1.08	I	20	<b>3C165</b>	53	3480	2850	3.40-41
		1.51	II	20	<b>3D165</b>	53	4810	3930	3.40-41
		1.71	II	20	<b>3D170</b>	53	4810	3930	3.40-41
		2.01	III	20	<b>3E175</b>	53	5170	4110	3.40-41
29.2	39700	1.26	I	20	<b>3D165</b>	60	4810	3930	3.40-41
		1.32	I	20	<b>3D170</b>	60	4810	3930	3.40-41
		1.62	II	20	<b>3D175</b>	60	4810	3930	3.40-41
23.6	49100	1.08	I	20	<b>3D165</b>	74	4810	3930	3.40-41
		1.48	II	20	<b>3E175</b>	74	5170	4110	3.40-41
19.9	58275	1.01	I	20	<b>3D165</b>	88	4810	3930	3.40-41
		1.24	I	20	<b>3E175</b>	88	5170	4110	3.40-41
17.2	67400	1.07	I	20	<b>3E175</b>	102	5170	4110	3.40-41

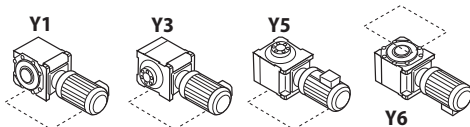
Gearmotors

Selection Tables

### 25 HP

Output Speed RPM	Output Torque in•lb	Service Factor		SELECTION			Overhung Load (lbs)		Dimension Page LHYM
		SF	AGMA Class	HP Symbol	Frame Size	Ratio	Hollow Shaft	Solid Shaft	
159	9100	1.09	I	25	<b>3B160</b>	11	2070	1640	3.38-39
		1.48	II	25	<b>3C170</b>	11	3480	2850	3.40-41
		1.61	II	25	<b>3C175</b>	11	3480	2850	3.40-41
97.2	14900	1.09	I	25	<b>3B160</b>	18	2070	1640	3.38-39
		1.48	II	25	<b>3C170</b>	18	3480	2850	3.40-41
83.3	17400	1.09	I	25	<b>3C160</b>	21	3480	2850	3.40-41
		1.48	II	25	<b>3C170</b>	21	3480	2850	3.40-41
62.5	23190	1.06	I	25	<b>3C160</b>	28	3480	2850	3.40-41
		1.29	I	25	<b>3C165</b>	28	3480	2850	3.40-41
		1.48	II	25	<b>3C170</b>	28	3480	2850	3.40-41
44.9	32285	1.06	I	25	<b>3C160</b>	39	3480	2850	3.40-41
		1.29	I	25	<b>3D165</b>	39	4810	3930	3.40-41
		1.48	II	25	<b>3D170</b>	39	4810	3930	3.40-41
38.0	38145	1.06	I	25	<b>3D160</b>	46	4810	3930	3.40-41
		1.46	II	25	<b>3D170</b>	46	4810	3930	3.40-41
33.0	43900	1.00	I	25	<b>3D160</b>	53	4810	3930	3.40-41
		1.47	II	25	<b>3D175</b>	53	4810	3930	3.40-41
		1.61	II	25	<b>3E175</b>	53	5170	4110	3.40-41
29.2	49600	1.01	I	25	<b>3D165</b>	60	4810	3930	3.40-41
		1.29	I	25	<b>3D175</b>	60	4810	3930	3.40-41
23.6	61400	1.05	I	25	<b>3D175</b>	74	4810	3930	3.40-41

# 60 Hz, 1750 RPM Gearmotor Selection Tables



## Horizontal Motor Shaft Y1, Y3, Y5, Y6 Mounting Positions

**30 HP**

Output Speed RPM	Output Torque in•lb	Service Factor		SELECTION			Overhung Load (lbs)		Dimension Page LHYM
		SF	AGMA Class	HP Symbol	Frame Size	Ratio	Hollow Shaft	Solid Shaft	
159	10900	1.34	I	30	<b>3C175</b>	11	3480	2850	3.40-41
97.2	17850	1.34	I	30	<b>3C175</b>	18	3480	2850	3.40-41
83.3	20880	1.08	I	30	<b>3C165</b>	21	3480	2850	3.40-41
		1.34	I	30	<b>3C175</b>	21	3480	2850	3.40-41
62.5	27800	1.08	I	30	<b>3C165</b>	28	3480	2850	3.40-41
		1.34	I	30	<b>3C175</b>	28	3480	2850	3.40-41
44.9	38700	1.08	I	30	<b>3D165</b>	39	4810	3930	3.40-41
		1.34	I	30	<b>3D175</b>	39	4810	3930	3.40-41
38.0	45700	1.01	I	30	<b>3D165</b>	46	4810	3930	3.40-41
		1.34	I	30	<b>3D175</b>	46	4810	3930	3.40-41
33.0	52700	1.00	I	30	<b>3D165</b>	53	4810	3930	3.40-41
		1.34	I	30	<b>3E175</b>	53	5170	4110	3.40-41
29.2	59500	1.08	I	30	<b>3D175</b>	60	4810	3930	3.40-41

Gearmotors

Selection Tables

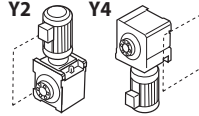
**40 HP**

Output Speed RPM	Output Torque in•lb	Service Factor		SELECTION			Overhung Load (lbs)		Dimension Page LHYM
		SF	AGMA Class	HP Symbol	Frame Size	Ratio	Hollow Shaft	Solid Shaft	
159	14500	1.01	I	40	<b>3C175</b>	11	3480	2850	3.40-41
97.2	23800	1.01	I	40	<b>3C175</b>	18	3480	2850	3.40-41
83.3	27800	1.01	I	40	<b>3C175</b>	21	3480	2850	3.40-41
62.5	37100	1.01	I	40	<b>3C175</b>	28	3480	2850	3.40-41
44.9	51600	1.01	I	40	<b>3D175</b>	39	4810	3930	3.40-41
38.0	61000	1.01	I	40	<b>3D175</b>	46	4810	3930	3.40-41
33.0	70200	1.01	I	40	<b>3E175</b>	53	5170	4110	3.40-41



# Gearmotor Selection Tables 60 Hz, 1750 RPM

## Vertical Motor Shaft Y2, Y4 Mounting Positions



### 1/4 HP

Output Speed RPM	Output Torque in•lb	Service Factor		SELECTION			Overhung Load (lbs)		Dimension Page LHYM
		SF	AGMA Class	HP Symbol	Frame Size	Ratio	Hollow Shaft	Solid Shaft	
8.45	1714	2.77	III	02	<b>3A100</b>	207	1120	990	3.38-39
7.03	2062	2.34	III	02	<b>3A100</b>	249	1120	990	3.38-39
5.74	2525	2.32	III	02	<b>3A100</b>	305	1120	990	3.38-39
4.20	3451	1.13	I	02	<b>3A100</b>	417	1120	990	3.38-39

### 1/3 HP

Output Speed RPM	Output Torque in•lb	Service Factor		SELECTION			Overhung Load (lbs)		Dimension Page LHYM
		SF	AGMA Class	HP Symbol	Frame Size	Ratio	Hollow Shaft	Solid Shaft	
9.78	1956	2.25	III	03	<b>3A100</b>	179	1120	990	3.38-39
8.45	2264	2.08	III	03	<b>3A100</b>	207	1120	990	3.38-39
7.03	2722	1.76	II	03	<b>3A100</b>	249	1120	990	3.38-39
		2.25	III	03	<b>3A105</b>	249	1120	990	3.38-39
5.74	3334	1.74	II	03	<b>3A100</b>	305	1120	990	3.38-39
		2.28	III	03	<b>3A105</b>	305	1120	990	3.38-39
4.20	4602	1.15	I	03	<b>3A105</b>	417	1120	990	3.38-39

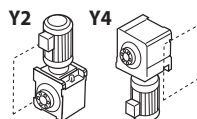
### 1/2 HP

Output Speed RPM	Output Torque in•lb	Service Factor		SELECTION			Overhung Load (lbs)		Dimension Page LHYM
		SF	AGMA Class	HP Symbol	Frame Size	Ratio	Hollow Shaft	Solid Shaft	
11.6	2499	2.10	III	05	<b>3A100</b>	151	1120	990	3.38-39
9.78	2964	1.50	II	05	<b>3A100</b>	179	1120	990	3.38-39
		2.08	III	05	<b>3A105</b>	179	1120	990	3.38-39
8.45	3431	1.38	I	05	<b>3A100</b>	207	1120	990	3.38-39
		1.90	II	05	<b>3A105</b>	207	1120	990	3.38-39
7.03	4124	2.30	III	05	<b>3A110</b>	207	1120	990	3.38-39
		1.17	I	05	<b>3A100</b>	249	1120	990	3.38-39
5.74	5051	1.50	II	05	<b>3A105</b>	249	1120	990	3.38-39
		2.04	III	05	<b>3A115</b>	249	1120	990	3.38-39
5.74	5051	1.16	I	05	<b>3A100</b>	305	1120	990	3.38-39
		1.52	II	05	<b>3A105</b>	305	1120	990	3.38-39
		2.54	III	05	<b>3B120</b>	305	2070	1640	3.38-39

Gearmotors

Selection Tables

# 60 Hz, 1750 RPM Gearmotor Selection Tables



## Vertical Motor Shaft Y2, Y4 Mounting Positions

**3/4 HP**

Output Speed RPM	Output Torque in•lb	Service Factor		SELECTION			Overhung Load (lbs)		Dimension Page LHYM
		SF	AGMA Class	HP Symbol	Frame Size	Ratio	Hollow Shaft	Solid Shaft	
19.9	2185	2.27	III	08	<b>3A100</b>	88	1120	990	3.38-39
	2528	2.16	III	08	<b>3A100</b>	102	1120	990	3.38-39
14.3	3041	1.75	II	08	<b>3A100</b>	123	1120	990	3.38-39
		2.15	III	08	<b>3A105</b>	123	1120	990	3.38-39
11.6	3749	1.40	II	08	<b>3A100</b>	151	1120	990	3.38-39
		2.32	III	08	<b>3A110</b>	151	1120	990	3.38-39
9.78	4447	1.00	I	08	<b>3A100</b>	179	1120	990	3.38-39
		1.69	II	08	<b>3A110</b>	179	1120	990	3.38-39
		2.13	III	08	<b>3A125</b>	179	1120	990	3.38-39
8.45	5146	1.27	I	08	<b>3A105</b>	207	1120	990	3.38-39
		1.53	II	08	<b>3A110</b>	207	1120	990	3.38-39
		2.32	III	08	<b>3B120</b>	207	2070	1640	3.38-39
7.03	6186	1.00	I	08	<b>3A105</b>	249	1120	990	3.38-39
		1.53	II	08	<b>3A125</b>	249	1120	990	3.38-39
		2.15	III	08	<b>3B125</b>	249	2070	1640	3.38-39
5.74	7576	1.01	I	08	<b>3A105</b>	305	1120	990	3.38-39
		1.69	II	08	<b>3B120</b>	305	2070	1640	3.38-39
		2.03	III	08	<b>3B125</b>	305	2070	1640	3.38-39

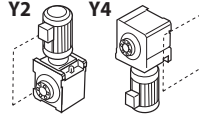
**1 HP**

Output Speed RPM	Output Torque in•lb	Service Factor		SELECTION			Overhung Load (lbs)		Dimension Page LHYM
		SF	AGMA Class	HP Symbol	Frame Size	Ratio	Hollow Shaft	Solid Shaft	
19.9	2914	1.70	II	1	<b>3A100</b>	88	1120	990	3.38-39
		2.24	III	1	<b>3A105</b>	88	1120	990	3.38-39
17.2	3371	1.62	II	1	<b>3A100</b>	102	1120	990	3.38-39
		2.13	III	1	<b>3A105</b>	102	1120	990	3.38-39
14.2	4083	1.31	I	1	<b>3A100</b>	123	1120	990	3.38-39
		1.61	II	1	<b>3A105</b>	123	1120	990	3.38-39
11.6	4999	2.01	III	1	<b>3A110</b>	123	1120	990	3.38-39
		1.05	I	1	<b>3A100</b>	151	1120	990	3.38-39
9.78	5929	1.45	II	1	<b>3A105</b>	151	1120	990	3.38-39
		2.56	III	1	<b>3B120</b>	151	1120	990	3.38-39
8.45	6862	1.04	I	1	<b>3A105</b>	179	1120	990	3.38-39
		1.49	II	1	<b>3A115</b>	179	1120	990	3.38-39
		2.31	III	1	<b>3B120</b>	179	2070	1640	3.38-39
7.03	8248	1.15	I	1	<b>3A110</b>	207	1120	990	3.38-39
		1.74	II	1	<b>3B120</b>	207	2070	1640	3.38-39
		2.17	III	1	<b>3B125</b>	207	2070	1640	3.38-39
5.74	10102	1.02	I	1	<b>3A115</b>	249	1120	990	3.38-39
		1.61	II	1	<b>3B125</b>	249	2070	1640	3.38-39
		2.04	III	1	<b>3B145</b>	249	2070	1640	3.38-39
5.74	10102	1.27	I	1	<b>3B120</b>	305	2070	1640	3.38-39
		1.52	II	1	<b>3B125</b>	305	2070	1640	3.38-39
		1.86	II	1	<b>3B145</b>	305	2070	1640	3.38-39

Gearmotors  
Selection Tables

# Gearmotor Selection Tables 60 Hz, 1750 RPM

## Vertical Motor Shaft Y2, Y4 Mounting Positions

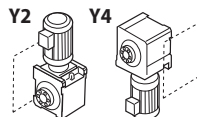


### 1.5 HP

Output Speed RPM	Output Torque in•lb	Service Factor		SELECTION			Overhung Load (lbs)		Dimension Page LHYM
		SF	AGMA Class	HP Symbol	Frame Size	Ratio	Hollow Shaft	Solid Shaft	
159	547	2.10	III	1H*	<b>3A100</b>	11	1120	990	3.38-39
97.2	895	2.10	III	1H*	<b>3A100</b>	18	1120	990	3.38-39
83.3	1044	2.10	III	1H	<b>3A100</b>	21	1120	990	3.38-39
62.5	1392	2.10	III	1H	<b>3A100</b>	28	1120	990	3.38-39
44.9	1937	2.10	III	1H	<b>3A100</b>	39	1120	990	3.38-39
38.0	2289	2.10	III	1H	<b>3A100</b>	46	1120	990	3.38-39
33.0	2636	2.10	III	1H	<b>3A100</b>	53	1120	990	3.38-39
29.2	2979	1.78	II	1H	<b>3A100</b>	60	1120	990	3.38-39
		2.20	III	1H	<b>3A105</b>	60	1120	990	3.38-39
23.6	3685	1.72	II	1H	<b>3A100</b>	74	1120	990	3.38-39
		2.09	III	1H	<b>3A105</b>	74	1120	990	3.38-39
19.9	4371	1.13	I	1H	<b>3A100</b>	88	1120	990	3.38-39
		1.49	II	1H	<b>3A105</b>	88	1120	990	3.38-39
		2.17	III	1H	<b>3A125</b>	88	1120	990	3.38-39
17.2	5057	1.08	I	1H	<b>3A100</b>	102	1120	990	3.38-39
		1.42	II	1H	<b>3A105</b>	102	1120	990	3.38-39
		2.67	III	1H	<b>3B120</b>	102	2070	1640	3.38-39
14.2	6125	1.07	I	1H	<b>3A105</b>	123	1120	990	3.38-39
		1.55	II	1H	<b>3A115</b>	123	1120	990	3.38-39
		2.23	III	1H	<b>3B120</b>	123	2070	1640	3.38-39
11.6	7498	1.16	I	1H	<b>3A110</b>	151	1120	990	3.38-39
		1.71	II	1H	<b>3B120</b>	151	2070	1640	3.38-39
		2.13	III	1H	<b>3B125</b>	151	2070	1640	3.38-39
9.78	8893	1.07	I	1H	<b>3A125</b>	179	1120	990	3.38-39
		1.54	II	1H	<b>3B120</b>	179	2070	1640	3.38-39
		2.04	III	1H	<b>3B125</b>	179	2070	1640	3.38-39
8.45	10293	1.16	I	1H	<b>3B120</b>	207	2070	1640	3.38-39
		1.45	II	1H	<b>3B125</b>	207	2070	1640	3.38-39
		1.83	II	1H	<b>3B145</b>	207	2070	1640	3.38-39
7.03	12372	1.07	I	1H	<b>3B125</b>	249	2070	1640	3.38-39
		1.52	II	1H	<b>3B165</b>	249	2070	1640	3.38-39
		1.99	II	1H	<b>3C165</b>	249	3480	2850	3.40-41
5.74	15152	1.01	I	1H	<b>3B125</b>	305	2070	1640	3.38-39
		1.24	I	1H	<b>3B145</b>	305	2070	1640	3.38-39
		1.36	I	1H	<b>3C145</b>	305	3480	2850	3.40-41

\* These Models are not available for Y4 Mounting Position

# 60 Hz, 1750 RPM Gearmotor Selection Tables



## Vertical Motor Shaft Y2, Y4 Mounting Positions

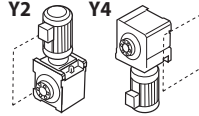
**2 HP**

Output Speed RPM	Output Torque in•lb	Service Factor		SELECTION			Overhung Load (lbs)		Dimension Page LHYM
		SF	AGMA Class	HP Symbol	Frame Size	Ratio	Hollow Shaft	Solid Shaft	
159	729	1.58	II	2*	<b>3A100</b>	11	1120	990	3.38–39
		2.13	III	2*	<b>3A105</b>	11	1120	990	3.38–39
97.2	1193	1.58	II	2*	<b>3A100</b>	18	1120	990	3.38–39
		2.13	III	2*	<b>3A105</b>	18	1120	990	3.38–39
83.3	1392	1.58	II	2	<b>3A100</b>	21	1120	990	3.38–39
		2.13	III	2	<b>3A105</b>	21	1120	990	3.38–39
62.5	1855	1.58	II	2	<b>3A100</b>	28	1120	990	3.38–39
		2.13	III	2	<b>3A105</b>	28	1120	990	3.38–39
44.9	2583	1.58	II	2	<b>3A100</b>	39	1120	990	3.38–39
		2.13	III	2	<b>3A105</b>	39	1120	990	3.38–39
38.0	3052	1.58	II	2	<b>3A100</b>	46	1120	990	3.38–39
		2.13	III	2	<b>3A105</b>	46	1120	990	3.38–39
33.0	3514	1.58	II	2	<b>3A100</b>	53	1120	990	3.38–39
		2.13	III	2	<b>3A105</b>	53	1120	990	3.38–39
29.2	3971	1.34	I	2	<b>3A100</b>	60	1120	990	3.38–39
		1.65	II	2	<b>3A105</b>	60	1120	990	3.38–39
		2.13	III	2	<b>3A110</b>	60	1120	990	3.38–39
23.6	4914	1.30	I	2	<b>3A100</b>	74	1120	990	3.38–39
		1.57	II	2	<b>3A105</b>	74	1120	990	3.38–39
		2.66	III	2	<b>3B120</b>	74	2070	1640	3.38–39
19.9	5827	1.12	I	2	<b>3A105</b>	88	1120	990	3.38–39
		1.49	II	2	<b>3A115</b>	88	1120	990	3.38–39
		2.07	III	2	<b>3B120</b>	88	2070	1640	3.38–39
17.2	6742	1.07	I	2	<b>3A105</b>	102	1120	990	3.38–39
		1.41	II	2	<b>3A115</b>	102	1120	990	3.38–39
		2.01	III	2	<b>3B120</b>	102	2070	1640	3.38–39
14.2	8167	1.01	I	2	<b>3A110</b>	123	1120	990	3.38–39
		1.67	II	2	<b>3B120</b>	123	2070	1640	3.38–39
		2.13	III	2	<b>3B125</b>	123	2070	1640	3.38–39
11.6	9997	1.28	I	2	<b>3B120</b>	151	2070	1640	3.38–39
		1.60	II	2	<b>3B125</b>	151	2070	1640	3.38–39
		2.51	III	2	<b>3C165</b>	151	3480	2850	3.40–41
9.78	11857	1.16	I	2	<b>3B120</b>	179	2070	1640	3.38–39
		1.53	II	2	<b>3B125</b>	179	2070	1640	3.38–39
		2.51	III	2	<b>3C165</b>	179	3480	2850	3.40–41
8.45	13724	1.09	I	2	<b>3B125</b>	207	2070	1640	3.38–39
		1.49	II	2	<b>3C145</b>	207	3480	2850	3.40–41
		2.51	III	2	<b>3C165</b>	207	3480	2850	3.40–41
7.03	16496	1.02	I	2	<b>3B145</b>	249	2070	1640	3.38–39
		1.49	II	2	<b>3C165</b>	249	3480	2850	3.40–41
5.74	20203	1.02	I	2	<b>3C145</b>	305	3480	2850	3.40–41
		1.49	II	2	<b>3C165</b>	305	3480	2850	3.40–41

\* These Models are not available for Y4 Mounting Position

# Gearmotor Selection Tables 60 Hz, 1750 RPM

## Vertical Motor Shaft Y2, Y4 Mounting Positions

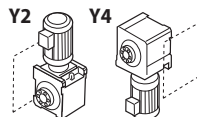


### 3 HP

Output Speed RPM	Output Torque in•lb	Service Factor		SELECTION			Overhung Load (lbs)		Dimension Page LHYM
		SF	AGMA Class	HP Symbol	Frame Size	Ratio	Hollow Shaft	Solid Shaft	
159	1094	1.05	I	3*	<b>3A100</b>	11	1120	990	3.38-39
		1.42	II	3*	<b>3A105</b>	11	1120	990	3.38-39
		2.27	III	3*	<b>3A120</b>	11	1120	990	3.38-39
97.2	1790	1.05	I	3*	<b>3A100</b>	18	1120	990	3.38-39
		1.42	II	3*	<b>3A105</b>	18	1120	990	3.38-39
		2.27	III	3*	<b>3A120</b>	18	1120	990	3.38-39
83.3	2088	1.05	I	3	<b>3A100</b>	21	1120	990	3.38-39
		1.42	II	3	<b>3A105</b>	21	1120	990	3.38-39
		2.27	III	3	<b>3A120</b>	21	1120	990	3.38-39
62.5	2783	1.05	I	3	<b>3A100</b>	28	1120	990	3.38-39
		1.42	II	3	<b>3A105</b>	28	1120	990	3.38-39
		2.27	III	3	<b>3A120</b>	28	1120	990	3.38-39
44.9	3874	1.05	I	3	<b>3A100</b>	39	1120	990	3.38-39
		1.42	II	3	<b>3A105</b>	39	1120	990	3.38-39
		2.27	III	3	<b>3A120</b>	39	1120	990	3.38-39
38.0	4578	1.05	I	3	<b>3A100</b>	46	1120	990	3.38-39
		1.42	II	3	<b>3A105</b>	46	1120	990	3.38-39
		2.09	III	3	<b>3A125</b>	46	1120	990	3.38-39
33.0	5271	1.05	I	3	<b>3A100</b>	53	1120	990	3.38-39
		1.42	II	3	<b>3A105</b>	53	1120	990	3.38-39
		2.27	III	3	<b>3B120</b>	53	2070	1640	3.38-39
29.2	5957	1.10	I	3	<b>3A105</b>	60	1120	990	3.38-39
		1.42	II	3	<b>3A110</b>	60	1120	990	3.38-39
		2.27	III	3	<b>3B120</b>	60	2070	1640	3.38-39
23.6	7371	1.05	I	3	<b>3A105</b>	74	1120	990	3.38-39
		1.77	II	3	<b>3B120</b>	74	2070	1640	3.38-39
		2.18	III	3	<b>3B125</b>	74	2070	1640	3.38-39
19.9	8741	1.09	I	3	<b>3A125</b>	88	1120	990	3.38-39
		1.77	II	3	<b>3B125</b>	88	2070	1640	3.38-39
		2.16	III	3	<b>3B145</b>	88	2070	1640	3.38-39
17.2	10113	1.34	I	3	<b>3B120</b>	102	2070	1640	3.38-39
		1.69	II	3	<b>3B125</b>	102	2070	1640	3.38-39
		1.86	II	3	<b>3B165</b>	102	2070	1640	3.38-39
14.2	12250	1.11	I	3	<b>3B120</b>	123	2070	1640	3.38-39
		1.42	II	3	<b>3B125</b>	123	2070	1640	3.38-39
		1.67	II	3	<b>3C145</b>	123	3480	2850	3.40-41
11.6	14996	1.06	I	3	<b>3B125</b>	151	2070	1640	3.38-39
		1.67	II	3	<b>3C165</b>	151	3480	2850	3.40-41
9.78	17786	1.02	I	3	<b>3B125</b>	179	2070	1640	3.38-39
		1.67	II	3	<b>3C165</b>	179	3480	2850	3.40-41
8.45	20586	1.67	II	3	<b>3C165</b>	207	3480	2850	3.40-41

\* These Models are not available for Y4 Mounting Position

# 60 Hz, 1750 RPM Gearmotor Selection Tables



## Vertical Motor Shaft Y2, Y4 Mounting Positions

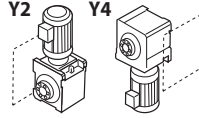
**5 HP**

Output Speed RPM	Output Torque in•lb	Service Factor		SELECTION			Overhung Load (lbs)		Dimension Page LHYM
		SF	AGMA Class	HP Symbol	Frame Size	Ratio	Hollow Shaft	Solid Shaft	
159	1823	1.36	I	5*	<b>3A120</b>	11	1120	990	3.38-39
		1.56	II	5*	<b>3A125</b>	11	1120	990	3.38-39
		2.54	III	5*	<b>3A140</b>	11	1120	990	3.38-39
97.2	2983	1.36	I	5*	<b>3A120</b>	18	1120	990	3.38-39
		1.56	II	5*	<b>3A125</b>	18	1120	990	3.38-39
		2.54	III	5*	<b>3A140</b>	18	1120	990	3.38-39
83.3	3480	1.05	I	5	<b>3A115</b>	21	1120	990	3.38-39
		1.56	II	5	<b>3A125</b>	21	1120	990	3.38-39
		2.46	III	5	<b>3A145</b>	21	1120	990	3.38-39
62.5	4639	1.05	I	5	<b>3A115</b>	28	1120	990	3.38-39
		1.86	II	5	<b>3A125</b>	28	1120	990	3.38-39
		2.02	III	5	<b>3A145</b>	28	1120	990	3.38-39
44.9	6457	1.05	I	5	<b>3A115</b>	39	1120	990	3.38-39
		1.48	II	5	<b>3A125</b>	39	1120	990	3.38-39
		2.94	III	5	<b>3B145</b>	39	2070	1640	3.38-39
38.0	7629	1.05	I	5	<b>3A115</b>	46	1120	990	3.38-39
		1.59	II	5	<b>3B125</b>	46	2070	1640	3.38-39
		2.04	III	5	<b>3B145</b>	46	2070	1640	3.38-39
33.0	8785	1.05	I	5	<b>3A115</b>	53	1120	990	3.38-39
		1.59	II	5	<b>3B125</b>	53	2070	1640	3.38-39
		2.04	III	5	<b>3B145</b>	53	2070	1640	3.38-39
29.2	9929	1.36	I	5	<b>3B120</b>	60	2070	1640	3.38-39
		1.52	II	5	<b>3B125</b>	60	2070	1640	3.38-39
		2.98	III	5	<b>3C165</b>	60	3480	2850	3.40-41
23.6	12285	1.06	I	5	<b>3B120</b>	74	2070	1640	3.38-39
		1.31	II	5	<b>3B125</b>	74	2070	1640	3.38-39
		2.04	III	5	<b>3C165</b>	74	3480	2850	3.40-41
19.9	14569	1.06	I	5	<b>3B125</b>	88	2070	1640	3.38-39
		1.49	II	5	<b>3C145</b>	88	3480	2850	3.40-41
		2.04	III	5	<b>3C165</b>	88	3480	2850	3.40-41
17.2	16856	1.01	I	5	<b>3B125</b>	102	2070	1640	3.38-39
		2.04	III	5	<b>3C165</b>	102	3480	2850	3.40-41
14.2	20417	1.00	I	5	<b>3C145</b>	123	3480	2850	3.40-41
		1.85	II	5	<b>3C165</b>	123	3480	2850	3.40-41
		2.04	III	5	<b>3D165</b>	123	4810	3930	3.40-41
11.6	24993	1.00	I	5	<b>3C165</b>	151	3480	2850	3.40-41
		1.51	II	5	<b>3C175</b>	151	3480	2850	3.40-41
		2.04	III	5	<b>3D175</b>	151	4810	3930	3.40-41
9.78	29644	1.00	I	5	<b>3C165</b>	179	3480	2850	3.40-41
		1.49	II	5	<b>3D175</b>	179	4810	3930	3.40-41
8.45	34309	1.00	I	5	<b>3C165</b>	207	3480	2850	3.40-41
		1.49	II	5	<b>3D175</b>	207	4810	3930	3.40-41
7.03	41240	1.00	I	5	<b>3D175</b>	249	4810	3930	3.40-41
5.74	50508	1.00	I	5	<b>3D175</b>	305	4810	3930	3.40-41

\* These Models are not available for Y4 Mounting Position

# Gearmotor Selection Tables 60 Hz, 1750 RPM

## Vertical Motor Shaft Y2, Y4 Mounting Positions



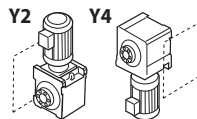
### 7.5 HP

Output Speed RPM	Output Torque in•lb	Service Factor		SELECTION			Overhung Load (lbs)		Dimension Page LHYM
		SF	AGMA Class	HP Symbol	Frame Size	Ratio	Hollow Shaft	Solid Shaft	
159	2735	1.04	I	8*	<b>3A125</b>	11	1120	990	3.38-39
		1.69	II	8*	<b>3A140</b>	11	1120	990	3.38-39
		2.25	III	8*	<b>3B160</b>	11	2070	1640	3.38-39
97.2	4474	1.04	I	8*	<b>3A125</b>	18	1120	990	3.38-39
		1.69	II	8*	<b>3A140</b>	18	1120	990	3.38-39
		2.25	III	8*	<b>3B160</b>	18	2070	1640	3.38-39
83.3	5221	1.04	I	8	<b>3A125</b>	21	1120	990	3.38-39
		1.64	II	8	<b>3A145</b>	21	1120	990	3.38-39
62.5	6958	1.24	I	8	<b>3A125</b>	28	1120	990	3.38-39
		1.99	II	8	<b>3B145</b>	28	2070	1640	3.38-39
		2.68	III	8	<b>3B165</b>	28	2070	1640	3.38-39
44.9	9685	1.06	I	8	<b>3B125</b>	39	2070	1640	3.38-39
		1.96	II	8	<b>3B145</b>	39	2070	1640	3.38-39
		2.72	III	8	<b>3C165</b>	39	3480	2850	3.40-41
38.0	11444	1.06	I	8	<b>3B125</b>	46	2070	1640	3.38-39
		1.67	II	8	<b>3B165</b>	46	2070	1640	3.38-39
33.0	13178	1.06	I	8	<b>3B125</b>	53	2070	1640	3.38-39
		1.44	II	8	<b>3B165</b>	53	2070	1640	3.38-39
		2.15	III	8	<b>3C175</b>	53	3480	2850	3.40-41
29.2	14893	1.01	I	8	<b>3B125</b>	60	2070	1640	3.38-39
		1.99	II	8	<b>3C165</b>	60	3480	2850	3.40-41
23.6	18427	1.03	I	8	<b>3B165</b>	74	2070	1640	3.38-39
		1.73	II	8	<b>3C175</b>	74	3480	2850	3.40-41
19.9	21853	1.36	I	8	<b>3C165</b>	88	3480	2850	3.40-41
		1.73	II	8	<b>3C175</b>	88	3480	2850	3.40-41
17.2	25283	1.36	I	8	<b>3C165</b>	102	3480	2850	3.40-41
		1.49	II	8	<b>3C175</b>	102	3480	2850	3.40-41
		1.99	II	8	<b>3D175</b>	102	4810	3930	3.40-41
14.2	30625	1.24	I	8	<b>3C165</b>	123	3480	2850	3.40-41
		1.36	I	8	<b>3D165</b>	123	4810	3930	3.40-41
11.6	37489	1.01	I	8	<b>3C175</b>	151	3480	2850	3.40-41
		1.36	I	8	<b>3D175</b>	151	4810	3930	3.40-41

\* These Models are not available for Y4 Mounting Position



# 60 Hz, 1750 RPM Gearmotor Selection Tables



## Vertical Motor Shaft Y2, Y4 Mounting Positions

**10 HP**

Output Speed RPM	Output Torque in•lb	Service Factor		SELECTION			Overhung Load (lbs)		Dimension Page LHYM
		SF	AGMA Class	HP Symbol	Frame Size	Ratio	Hollow Shaft	Solid Shaft	
159	3647	1.27	I	10*	<b>3A140</b>	11	1120	990	3.38–39
		1.48	II	10*	<b>3A145</b>	11	1120	990	3.38–39
		2.01	III	10*	<b>3B165</b>	11	2070	1640	3.38–39
97.2	5965	1.27	I	10*	<b>3A140</b>	18	1120	990	3.38–39
		1.48	II	10*	<b>3A145</b>	18	1120	990	3.38–39
		2.01	III	10*	<b>3B165</b>	18	2070	1640	3.38–39
83.3	6961	1.23	I	10	<b>3A145</b>	21	1120	990	3.38–39
		1.49	II	10	<b>3B145</b>	21	2070	1640	3.38–39
62.5	9277	1.01	I	10	<b>3A145</b>	28	1120	990	3.38–39
		1.49	II	10	<b>3B145</b>	28	2070	1640	3.38–39
		2.01	III	10	<b>3B165</b>	28	2070	1640	3.38–39
44.9	12914	1.47	II	10	<b>3B145</b>	39	2070	1640	3.38–39
		2.04	III	10	<b>3C165</b>	39	3480	2850	3.40–41
38.0	15259	1.02	I	10	<b>3B145</b>	46	2070	1640	3.38–39
		1.49	II	10	<b>3C165</b>	46	3480	2850	3.40–41
		2.49	III	10	<b>3C175</b>	46	3480	2850	3.40–41
33.0	17571	1.02	I	10	<b>3B145</b>	53	2070	1640	3.38–39
		1.49	II	10	<b>3C165</b>	53	3480	2850	3.40–41
29.2	19857	1.49	II	10	<b>3C165</b>	60	3480	2850	3.40–41
23.6	24569	1.02	I	10	<b>3C165</b>	74	3480	2850	3.40–41
19.9	29137	1.02	I	10	<b>3C165</b>	88	3480	2850	3.40–41
		1.49	II	10	<b>3D175</b>	88	4810	3930	3.40–41
17.2	33711	1.02	I	10	<b>3C165</b>	102	3480	2850	3.40–41
		1.49	II	10	<b>3D175</b>	102	4810	3930	3.40–41
14.2	40833	1.02	I	10	<b>3D165</b>	123	4810	3930	3.40–41
11.6	49985	1.02	I	10	<b>3D175</b>	151	4810	3930	3.40–41

Gearmotors

 Selection  
Tables

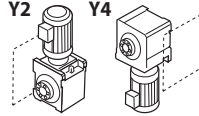
**15 HP**

Output Speed RPM	Output Torque in•lb	Service Factor		SELECTION			Overhung Load (lbs)		Dimension Page LHYM
		SF	AGMA Class	HP Symbol	Frame Size	Ratio	Hollow Shaft	Solid Shaft	
159	5470	1.13	I	15*	<b>3B160</b>	11	2070	1640	3.38–39
		1.81	II	15*	<b>3C170</b>	11	3480	2850	3.40–41
97.2	8948	1.13	I	15*	<b>3B160</b>	18	2070	1640	3.38–39
		1.81	II	15*	<b>3C170</b>	18	3480	2850	3.40–41
62.5	13916	1.34	I	15	<b>3B165</b>	28	2070	1640	3.38–39
44.9	19371	1.36	I	15	<b>3C165</b>	39	3480	2850	3.40–41
38.0	22888	1.66	II	15	<b>3C175</b>	46	3480	2850	3.40–41
33.0	26356	1.07	I	15	<b>3C175</b>	53	3480	2850	3.40–41

\* These Models are not available for Y4 Mounting Position

# Gearmotor Selection Tables 60 Hz, 1750 RPM

## Vertical Motor Shaft Y2, Y4 Mounting Positions



### 20 HP

Output Speed RPM	Output Torque in•lb	Service Factor		SELECTION			Overhung Load (lbs)		Dimension Page LHYM
		SF	AGMA Class	HP Symbol	Frame Size	Ratio	Hollow Shaft	Solid Shaft	
159	7293	1.01	I	20*	<b>3B165</b>	11	2070	1640	3.38–39
		1.48	II	20*	<b>3C175</b>	11	3480	2850	3.40–41
97.2	11931	1.01	I	20*	<b>3B165</b>	18	2070	1640	3.38–39
		1.48	II	20*	<b>3C175</b>	18	3480	2850	3.40–41
62.5	18555	1.01	I	20	<b>3B165</b>	28	2070	1640	3.38–39
44.9	25828	1.02	I	20	<b>3C165</b>	39	3480	2850	3.40–41
38.0	30517	1.25	I	20	<b>3C175</b>	46	3480	2850	3.40–41

### 25 HP

Output Speed RPM	Output Torque in•lb	Service Factor		SELECTION			Overhung Load (lbs)		Dimension Page LHYM
		SF	AGMA Class	HP Symbol	Frame Size	Ratio	Hollow Shaft	Solid Shaft	
159	9117	1.08	I	25*	<b>3C170</b>	11	3480	2850	3.40–41
97.2	14913	1.08	I	25*	<b>3C170</b>	18	3480	2850	3.40–41

\* These Models are not available for Y4 Mounting Position

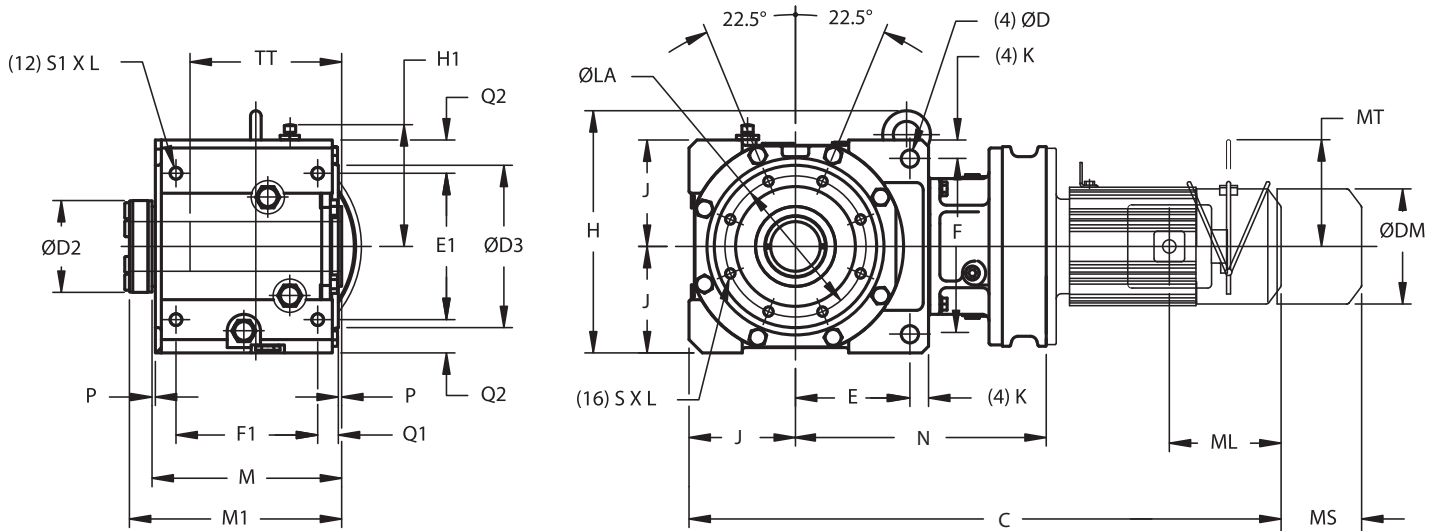
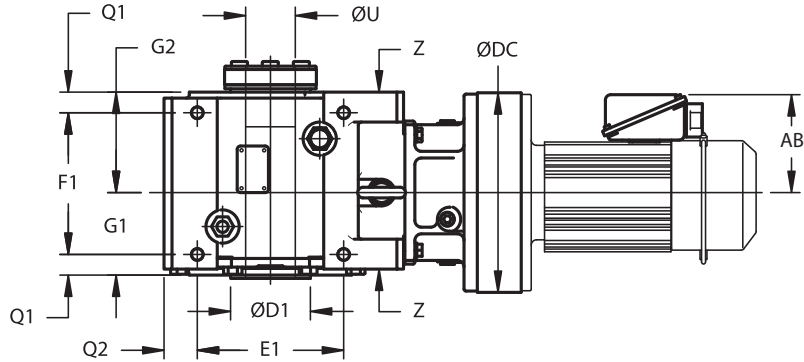
---

This page intentionally left blank.

# Dimensions Gearmotors

## Single Reduction LHYM-3A100~3B165

Min. Engagement	
FRAME SIZE	TT
3A	7.79
3B	9.33
3C	10.16
3D	11.82



All dimensions are in inches.

Model	N	ØDC	J	E	F	K	Z	ØD	E1	F1	Q1	Q2	S1 x L
3A100, 3A105	9.33	5.91											
3A110, 3A115	9.76	6.38	4.33	4.49	7.24	0.71	1.38	0.71	5.91	6.30	0.91	1.38	M12 x 0.79
3A120, 3A125	9.57	8.03											
3A140, 3A145	10.43	9.06											
3B120, 3B125	11.02	8.03											
3B140, 3B145	11.69	9.06	5.12	5.59	8.43	0.91	1.58	0.87	7.48	7.68	1.06	1.38	M16 x 1.02
3B160, 3B165	12.83	11.81											

Model	M	P	G1	G2	H	H1	ØLA	ØD3	S x L	M1	ØD1	ØD2	ØU	
													Std & Max	Min
3A100, 3A105														
3A110, 3A115	8.50	0.20	3.78	4.33	10.87	5.16	6.10	6.89	M10 x 0.67	9.84	3.35	4.09	2-3/16	1-11/16
3A120, 3A125														
3A140, 3A145														
3B120, 3B125														
3B140, 3B145	10.20	0.20	4.80	5.00	12.13	5.94	6.89	7.83	M12 x 0.79	11.54	3.94	4.49	2-7/16	1-15/16
3B160, 3B165														

Dimensions shown are for reference only and are subject to change without notice, unless certified.  
Certified prints are available after receipt of an order; consult factory.

## Single Reduction LHYM-3A100~3B165 Dimensions

All dimensions are in inches.

Model	4 Pole Motor HP	Without Brake					With Brake						
		C	ØDM	AB	ML	W (lb)	C	ØDM	AB	ML	MS	MT	W (lb)
3A100, 3A105	1/4	20.61	4.88	5.04	2.32	115	21.85	4.88	5.04	3.58	2.40	-	117
	1/3	20.61	4.88	5.04	2.32	115	21.85	4.88	5.04	3.58	2.40	-	117
	1/2	21.39	4.88	5.04	2.32	117	22.64	4.88	5.04	3.58	2.40	-	121
	3/4	23.01	5.83	5.63	3.82	126	24.69	5.83	5.63	5.51	3.66	4.17	132
	1	23.01	5.83	5.63	3.82	126	24.69	5.83	5.63	5.51	3.66	4.17	132
	1.5	24.31	6.30	5.83	3.94	135	26.73	6.30	5.83	6.38	4.53	4.49	146
	2	24.31	6.30	5.83	3.94	135	26.73	6.30	5.83	6.38	4.53	4.49	146
	3	25.09	6.81	6.10	4.13	143	27.56	6.81	6.10	6.61	4.76	4.88	159
3A110, 3A115	1/2	21.70	4.88	5.04	2.32	126	22.91	4.88	5.04	3.58	2.40	-	130
	3/4	23.28	5.83	5.63	3.82	132	25.20	5.83	5.63	5.51	3.66	4.17	139
	1	23.28	5.83	5.63	3.82	132	25.20	5.83	5.63	5.51	3.66	4.17	139
	1.5	24.58	6.30	5.83	3.94	141	26.81	6.30	5.83	6.38	4.53	4.49	152
	2	24.58	6.30	5.83	3.94	141	26.81	6.30	5.83	6.38	4.53	4.49	152
	3	25.37	6.81	6.10	4.13	150	27.83	6.81	6.10	6.61	4.76	4.88	165
	5	26.74	8.35	6.54	5.00	170	29.57	8.35	6.54	7.83	5.20	6.18	192
3A120, 3A125	1.5	24.53	6.30	5.83	3.94	150	26.97	6.30	5.83	6.38	4.53	4.49	161
	2	24.53	6.30	5.83	3.94	150	26.97	6.30	5.83	6.38	4.53	4.49	161
	3	25.31	6.81	6.10	4.13	159	27.80	6.81	6.10	6.61	4.76	4.88	174
	5	26.22	8.35	6.54	5.00	181	29.06	8.35	6.54	7.83	5.20	6.18	203
	7.5	27.95	8.35	6.54	5.00	196	30.79	8.35	6.54	7.83	5.20	6.18	218
3A140, 3A145	7.5	28.81	8.35	6.54	5.00	212	31.65	8.35	6.54	7.83	5.20	6.18	234
	10	29.73	9.49	8.31	5.63	243	33.46	9.49	8.31	9.37	6.69	7.17	282
	15	32.09	9.88	8.31	5.63	273	35.83	9.88	8.31	9.37	6.69	7.17	313
	20	35.63	12.76	10.31	11.61	395	39.76	12.76	10.31	15.16	8.66	-	467
3B120, 3B125	3/4	25.49	5.83	5.63	3.82	203	27.17	5.83	5.63	5.51	3.66	4.17	209
	1	25.49	5.83	5.63	3.82	203	27.17	5.83	5.63	5.51	3.66	4.17	209
	1.5	26.79	6.30	5.83	3.94	212	29.21	6.30	5.83	6.38	4.53	4.49	223
	2	26.79	6.30	5.83	3.94	212	29.21	6.30	5.83	6.38	4.53	4.49	223
	3	27.57	6.81	6.10	4.13	221	30.04	6.81	6.10	6.61	4.76	4.88	236
	5	28.48	8.35	6.54	5.00	243	31.30	8.35	6.54	7.83	5.20	6.18	265
	7.5	30.21	8.35	6.54	5.00	258	33.03	8.35	6.54	7.83	5.20	6.18	280
3B140, 3B145	1	26.14	5.83	5.63	3.82	221	27.83	5.83	5.63	5.51	3.66	4.17	227
	1.5	27.44	6.30	5.83	3.94	229	29.88	6.30	5.83	6.38	4.53	4.49	240
	2	27.44	6.30	5.83	3.94	229	29.88	6.30	5.83	6.38	4.53	4.49	240
	3	28.23	6.81	6.10	4.13	236	30.71	6.81	6.10	6.61	4.76	4.88	251
	5	29.13	8.35	6.54	5.00	258	31.97	8.35	6.54	7.83	5.20	6.18	280
	7.5	30.87	8.35	6.54	5.00	273	33.70	8.35	6.54	7.83	5.20	6.18	295
	10	31.77	9.49	8.31	5.63	304	35.51	9.49	8.31	9.37	6.69	7.17	344
	15	34.13	9.88	8.31	5.63	335	37.87	9.88	8.31	9.37	6.69	7.17	375
	20	37.68	12.76	10.31	11.61	456	41.81	12.76	10.31	15.16	8.66	-	529
3B160, 3B165	5	30.29	8.35	6.54	5.00	304	33.11	8.35	6.54	7.83	5.20	6.18	326
	7.5	32.02	8.35	6.54	5.00	320	34.84	8.35	6.54	7.83	5.20	6.18	342
	10	33.12	9.49	8.31	5.63	353	36.85	9.49	8.31	9.37	6.69	7.17	392
	15	35.48	9.88	8.31	5.63	384	39.21	9.88	8.31	9.37	6.69	7.17	421
	20	38.83	12.76	10.31	11.61	503	42.95	12.76	10.31	15.16	8.66	-	576
	25	42.56	15.51	13.46	13.39	657	49.06	15.51	13.46	21.65	14.45	-	770
	30	42.56	15.51	13.46	13.39	657	49.06	15.51	13.46	21.65	14.45	-	770

Gearmotors

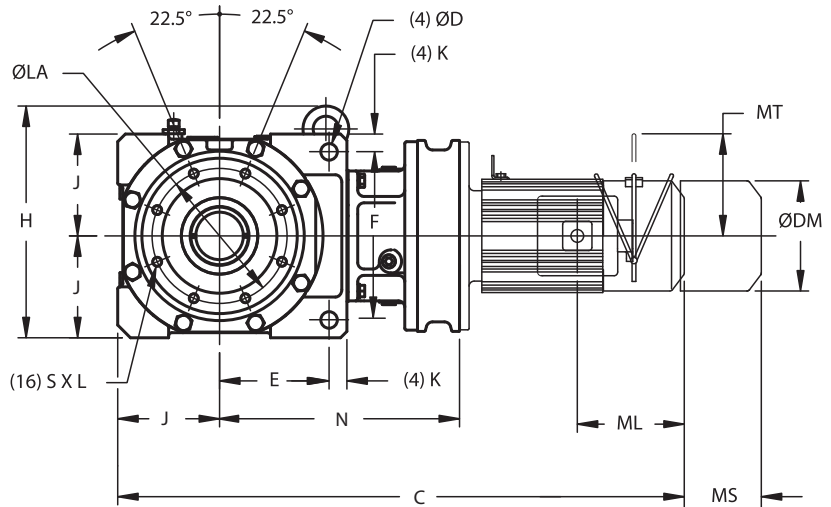
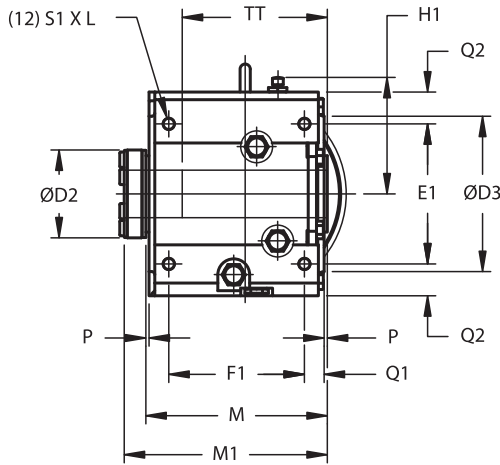
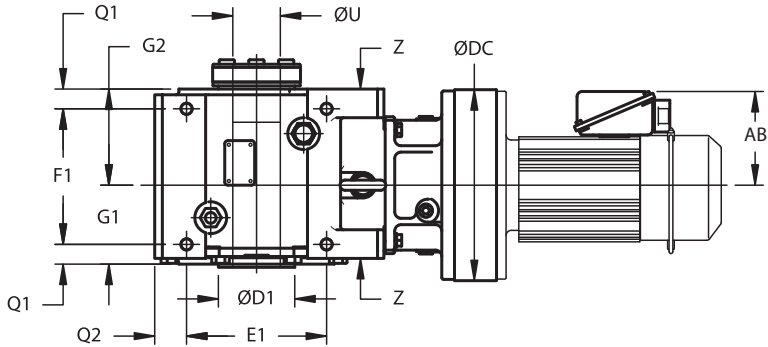
Dimensions

Dimensions shown are for reference only and are subject to change without notice, unless certified.  
 Certified prints are available after receipt of an order; consult factory.

# Dimensions

## Single Reduction LHYM-3C140~3E175

Min. Engagement	
FRAME SIZE	TT
3A	7.79
3B	9.33
3C	10.16
3D	11.82



Gearmotors  
Dimensions

All dimensions are in inches.

Model	N	ØDC	J	E	F	K	Z	ØD	E1	F1	Q1	Q2	S1 x L
3C140, 3C145	14.02	9.06											
3C160, 3C165	14.84	11.81	6.30	6.77	10.39	1.10	1.77	1.02	8.66	8.39	1.22	1.97	M20 x 1.30
3C170, 3C175	15.47	13.39											
3D160, 3D165	17.68	11.81	7.48	7.60	12.21	1.38	2.17	1.30	9.84	10.00	1.42	2.56	M24 x 1.57
3D170, 3D175	17.44	13.39											
3E170, 3E175	18.43	13.39	8.46	9.06	14.17	1.38	2.17	1.30	11.81	11.14	1.50	2.56	M24 x 1.57

Model	M	P	G1	G2	H	H1	ØLA	ØD3	S x L	M1	ØD1	ØD2	ØU	
													Std & Max	Min
3C140, 3C145														
3C160, 3C165	11.22	0.20	4.88	5.94	14.33	7.20	8.35	9.61	M16 x 1.02	12.83	4.72	5.43	2-15/16	2-3/16
3C170, 3C175														
3D160, 3D165	13.39	0.28	5.83	7.01	16.69	8.39	10.04	11.61	M20 x 1.30	15.00	5.51	5.98	3-7/16	2-7/16
3D170, 3D175														
3E170, 3E175	14.69	0.28	6.14	7.99	19.61	9.37	11.02	12.60	M20 x 1.38	16.30	6.30	6.69	3-15/16	2-15/16

Dimensions shown are for reference only and are subject to change without notice, unless certified.  
Certified prints are available after receipt of an order; consult factory.

## Single Reduction LHYM-3C140~3E175 Dimensions

All dimensions are in inches.

Model	4 Pole Motor HP	Without Brake					With Brake						
		C	ØDM	AB	ML	W (lb)	C	ØDM	AB	ML	MS	MT	W (lb)
3C140, 3C145	1.5	30.94	6.30	5.83	3.94	333	33.39	6.30	5.83	6.38	4.53	4.49	344
	2	30.94	6.30	5.83	3.94	333	33.39	6.30	5.83	6.38	4.53	4.49	344
	3	31.73	6.81	6.10	4.13	340	34.21	6.81	6.10	6.61	4.76	4.88	355
	5	32.64	8.35	6.54	5.00	362	35.47	8.35	6.54	7.83	5.20	6.18	384
	7.5	34.37	8.35	6.54	5.00	377	37.20	8.35	6.54	7.83	5.20	6.18	399
	10	35.28	9.88	8.31	5.63	408	39.02	9.88	8.31	9.37	6.69	7.17	448
	15	37.64	9.88	8.31	5.63	439	41.38	9.88	8.31	9.37	6.69	7.17	478
	20	41.18	12.76	10.31	11.61	560	45.31	12.76	10.31	15.16	8.66	-	635
3C160, 3C165	2	31.97	6.30	5.83	3.94	379	34.41	6.30	5.83	6.38	4.53	4.49	390
	3	32.56	6.81	6.10	4.13	386	35.04	6.81	6.10	6.61	4.76	4.88	401
	5	33.46	8.35	6.54	5.00	406	36.30	8.35	6.54	7.83	5.20	6.18	428
	7.5	35.20	8.35	6.54	5.00	421	38.03	8.35	6.54	7.83	5.20	6.18	443
	10	36.30	9.88	8.31	5.63	454	40.04	9.88	8.31	9.37	6.69	7.17	494
	15	38.66	9.88	8.31	5.63	485	42.40	9.88	8.31	9.37	6.69	7.17	523
	20	42.01	12.76	10.31	11.61	604	46.14	12.76	10.31	15.16	8.66	-	679
	25	45.75	15.51	13.46	13.39	759	52.24	15.51	13.46	21.65	14.45	-	871
3C170, 3C175	5	34.69	8.35	6.54	5.00	456	37.52	8.35	6.54	7.83	5.20	6.18	478
	7.5	36.42	8.35	6.54	5.00	472	39.25	8.35	6.54	7.83	5.20	6.18	494
	10	37.13	9.88	8.31	5.63	505	40.87	9.88	8.31	9.37	6.69	7.17	545
	15	39.49	9.88	8.31	5.63	536	43.23	9.88	8.31	9.37	6.69	7.17	576
	20	42.64	12.76	10.31	11.61	655	46.77	12.76	10.31	15.16	8.66	-	730
	25	46.38	15.51	13.46	13.39	584	52.87	15.51	13.46	21.65	14.45	-	917
	30	46.38	15.51	13.46	13.39	584	52.87	15.51	13.46	21.65	14.45	-	917
	40	46.38	15.51	13.46	13.39	856	52.87	15.51	13.46	21.65	14.57	-	950
3D160, 3D165	3	36.57	6.81	6.10	4.13	534	39.06	6.81	6.10	6.61	4.76	4.88	549
	5	37.48	8.35	6.54	5.00	553	40.31	8.35	6.54	7.83	5.20	6.18	576
	7.5	39.21	8.35	6.54	5.00	569	42.05	8.35	6.54	7.83	5.20	6.18	591
	10	40.31	9.88	8.31	5.63	602	44.06	9.88	8.31	9.37	6.69	7.17	642
	15	42.68	9.88	8.31	5.63	633	46.42	9.88	8.31	9.37	6.69	7.17	670
	20	46.02	12.76	10.31	11.61	752	50.16	12.76	10.31	15.16	8.66	-	827
	25	49.76	15.51	13.46	13.39	906	56.26	15.51	13.46	21.65	14.45	-	1019
	30	49.76	15.51	13.46	13.39	906	56.26	15.51	13.46	21.65	14.45	-	1019
3D170, 3D175	5	37.83	8.35	6.54	5.00	595	40.67	8.35	6.54	7.83	5.20	6.18	617
	7.5	39.57	8.35	6.54	5.00	611	42.40	8.35	6.54	7.83	5.20	6.18	633
	10	40.28	9.88	8.31	5.63	644	44.02	9.88	8.31	9.37	6.69	7.17	684
	15	42.64	9.88	8.31	5.63	675	46.38	9.88	8.31	9.37	6.69	7.17	714
	20	45.79	12.76	10.31	11.61	794	49.92	12.76	10.31	15.16	8.66	-	869
	25	49.53	15.51	13.46	13.39	944	56.02	15.51	13.46	21.65	14.45	-	1056
	30	49.53	15.51	13.46	13.39	944	56.02	15.51	13.46	21.65	14.45	-	1056
	40	49.53	15.51	13.46	13.39	994	56.02	15.51	13.46	21.65	14.57	-	1089
3E170, 3E175	5	39.80	8.35	6.54	5.00	759	42.64	8.35	6.54	7.83	5.20	6.18	781
	7.5	41.54	8.35	6.54	5.00	774	44.37	8.35	6.54	7.83	5.20	6.18	796
	10	42.24	9.88	8.31	5.63	807	45.98	9.88	8.31	9.37	6.69	7.17	847
	15	44.61	9.88	8.31	5.63	838	48.35	9.88	8.31	9.37	6.69	7.17	878
	20	47.76	12.76	10.31	11.61	957	51.89	12.76	10.31	15.16	8.66	-	1032
	25	51.50	15.51	13.46	13.39	1107	57.99	15.51	13.46	21.65	14.45	-	1219
	30	51.50	15.51	13.46	13.39	1107	57.99	15.51	13.46	21.65	14.45	-	1219
	40	51.50	15.51	13.46	13.39	1158	57.99	15.51	13.46	21.65	14.57	-	1252

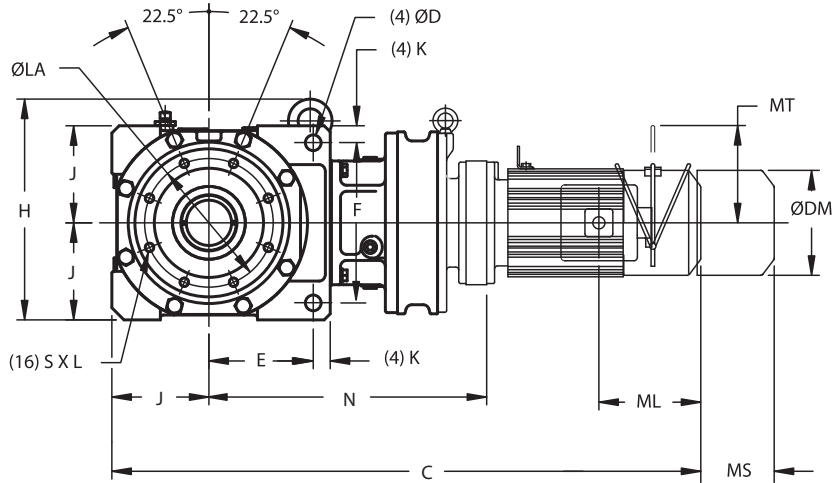
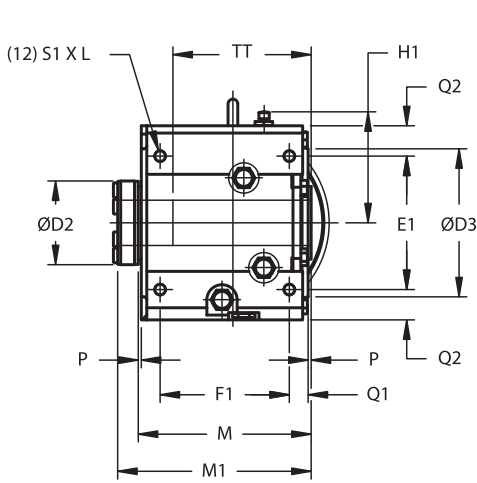
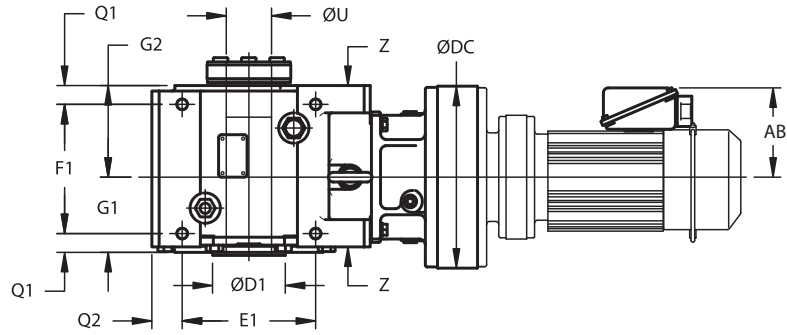
Dimensions shown are for reference only and are subject to change without notice, unless certified.  
Certified prints are available after receipt of an order; consult factory.



# Dimensions

## Double Reduction LHYM-3A10DA~3C16DB

Min. Engagement	
FRAME SIZE	TT
3A	7.79
3B	9.33
3C	10.16
3D	11.82



All dimensions are in inches.

Model	N	ØDC	J	E	F	K	Z	ØD	E1	F1	Q1	Q2	S1 x L	M
3A10DA	11.22	5.91												
3A12DA	11.69	8.03	4.33	4.49	7.24	0.71	1.38	0.71	5.91	6.30	0.91	1.38	M12x0.79	8.50
3A12DB	12.17	8.03												
3B12DA	13.15	8.03												
3B12DB	13.62	8.03												
3B14DA	13.82	9.06	5.12	5.59	8.43	0.91	1.58	0.87	7.48	7.68	1.06	1.38	M16x1.02	10.20
3B14DB	14.17	9.06												
3C14DA	16.14	9.06												
3C14DB	16.50	9.06												
3C14DC	17.05	9.06	6.30	6.77	10.39	1.10	1.77	1.02	8.66	8.39	1.22	1.97	M20x1.30	11.22
3C16DA	17.40	11.81												
3C16DB	17.95	11.81												

Model	P	G1	G2	H	H1	ØLA	ØD3	S x L	M1	ØD1	ØD2	ØU	
												Std & Max	Min
3A10DA													
3A12DA	0.20	3.78	4.33	10.87	5.16	6.10	6.89	M10 x 0.67	9.84	3.35	4.09	2-3/16	1-11/16
3A12DB													
3B12DA													
3B12DB													
3B14DA	0.20	4.80	5.00	12.13	5.94	6.89	7.83	M12 x 0.79	11.54	3.94	4.49	2-7/16	1-15/16
3B14DB													
3C14DA													
3C14DB													
3C14DC	0.20	4.88	5.94	14.33	7.20	8.35	9.61	M16 x 1.02	12.83	4.72	5.43	2-15/16	2-3/16
3C16DA													
3C16DB													

Dimensions shown are for reference only and are subject to change without notice, unless certified.  
Certified prints are available after receipt of an order; consult factory.

## Double Reduction LHYM-3A10DA~3C16DB Dimensions

All dimensions are in inches.

Model	4 Pole Motor HP	Without Brake					With Brake						
		C	ØDM	AB	ML	W (lb)	C	ØDM	AB	ML	MS	MT	W (lb)
3A10DA	1/8	20.83	4.88	5.04	1.38	117	22.20	4.88	5.04	2.76	2.40	-	119
	1/4	22.48	4.88	5.04	2.32	119	23.74	4.88	5.04	3.58	2.40	-	121
	1/3	22.48	4.88	5.04	2.32	119	23.74	4.88	5.04	3.58	2.40	-	121
	1/2	23.27	4.88	5.04	2.32	121	24.53	4.88	5.04	3.58	2.40	-	123
3A12DA	1/8	21.30	4.88	5.04	1.38	135	22.68	4.88	5.04	2.76	2.40	-	137
	1/4	22.95	4.88	5.04	2.32	137	24.21	4.88	5.04	3.58	2.40	-	139
	1/3	22.95	4.88	5.04	2.32	137	24.21	4.88	5.04	3.58	2.40	-	139
	1/2	23.74	4.88	5.04	2.32	139	25.00	4.88	5.04	3.58	2.40	-	141
3A12DB	1/3	23.43	4.88	5.04	2.32	143	24.69	4.88	5.04	3.58	2.40	-	148
	1/2	24.21	4.88	5.04	2.32	146	25.47	4.88	5.04	3.58	2.40	-	150
	3/4	25.83	5.83	5.63	3.82	154	27.52	5.83	5.63	5.51	3.66	4.17	161
	1	25.83	5.83	5.63	3.82	154	27.52	5.83	5.63	5.51	3.66	4.17	161
3B12DA	1/8	23.54	4.88	5.04	1.38	198	24.92	4.88	5.04	2.76	2.40	-	201
	1/4	25.20	4.88	5.04	2.32	201	26.46	4.88	5.04	3.58	2.40	-	203
	1/3	25.20	4.88	5.04	2.32	201	26.46	4.88	5.04	3.58	2.40	-	203
	1/2	25.98	4.88	5.04	2.32	203	27.24	4.88	5.04	3.58	2.40	-	205
3B12DB	1/3	25.67	4.88	5.04	2.32	207	26.93	4.88	5.04	3.58	2.40	-	212
	1/2	26.46	4.88	5.04	2.32	209	27.72	4.88	5.04	3.58	2.40	-	214
	3/4	28.07	5.83	5.63	3.82	218	29.76	5.83	5.63	5.51	3.66	4.17	225
	1	28.07	5.83	5.63	3.82	218	29.76	5.83	5.63	5.51	3.66	4.17	225
	1.5	29.37	6.30	5.83	3.94	225	31.81	6.30	5.83	6.38	4.53	4.49	236
3B14DA	1/4	25.87	4.88	5.04	2.32	209	27.13	4.88	5.04	3.58	2.40	-	212
	1/3	25.87	4.88	5.04	2.32	209	27.13	4.88	5.04	3.58	2.40	-	212
	1/2	26.65	4.88	5.04	2.32	212	27.91	4.88	5.04	3.58	2.40	-	214
3B14DB	1/4	26.22	4.88	5.04	2.32	214	27.48	4.88	5.04	3.58	2.40	-	218
	1/2	27.01	4.88	5.04	2.32	216	28.27	4.88	5.04	3.58	2.40	-	221
	3/4	28.62	5.83	5.63	3.82	225	30.31	5.83	5.63	5.51	3.66	4.17	232
	1	28.62	5.83	5.63	3.82	225	30.31	5.83	5.63	5.51	3.66	4.17	232
	1.5	29.92	6.30	5.83	3.94	232	32.36	6.30	5.83	6.38	4.53	4.49	243
	2	29.92	6.30	5.83	3.94	232	32.36	6.30	5.83	6.38	4.53	4.49	243
3C14DA	1/4	29.37	4.88	5.04	2.32	313	30.63	4.88	5.04	3.58	2.40	-	315
	1/3	29.37	4.88	5.04	2.32	313	30.63	4.88	5.04	3.58	2.40	-	315
	1/2	30.16	4.88	5.04	2.32	315	31.42	4.88	5.04	3.58	2.40	-	318
3C14DB	1/4	29.72	4.88	5.04	2.32	318	30.98	4.88	5.04	3.58	2.40	-	322
	1/3	29.72	4.88	5.04	2.32	318	30.98	4.88	5.04	3.58	2.40	-	322
	1/2	30.51	4.88	5.04	2.32	320	31.77	4.88	5.04	3.58	2.40	-	324
	3/4	32.13	5.83	5.63	3.82	329	33.82	5.83	5.63	5.51	3.66	4.17	335
	1	32.13	5.83	5.63	3.82	329	33.82	5.83	5.63	5.51	3.66	4.17	335
	1.5	33.43	6.30	5.83	3.94	335	35.87	6.30	5.83	6.38	4.53	4.49	346
	2	33.43	6.30	5.83	3.94	335	35.87	6.30	5.83	6.38	4.53	4.49	346
3C14DC	1.5	33.98	6.30	5.83	3.94	342	36.42	6.30	5.83	6.38	4.53	4.49	353
	2	33.98	6.30	5.83	3.94	342	36.42	6.30	5.83	6.38	4.53	4.49	353
	3	34.76	6.81	6.10	4.13	351	37.24	6.81	6.10	6.61	4.76	4.88	364
3C16DA	1/2	31.42	4.88	5.04	2.32	373	32.68	4.88	5.04	3.58	2.40	-	377
	3/4	33.03	5.83	5.63	3.82	381	34.72	5.83	5.63	5.51	3.66	4.17	388
	1	33.03	5.83	5.63	3.82	381	34.72	5.83	5.63	5.51	3.66	4.17	388
	1.5	34.33	6.30	5.83	3.94	390	32.83	6.30	5.83	6.38	4.53	4.49	401
	2	34.33	6.30	5.83	3.94	390	32.83	6.30	5.83	6.38	4.53	4.49	401
3C16DB	1.5	34.88	6.30	5.83	3.94	395	37.32	6.30	5.83	6.38	4.53	4.49	406
	2	34.88	6.30	5.83	3.94	395	37.32	6.30	5.83	6.38	4.53	4.49	406
	3	35.67	6.81	6.10	4.13	481	38.15	6.81	6.10	6.61	4.76	4.88	494

Gearmotors

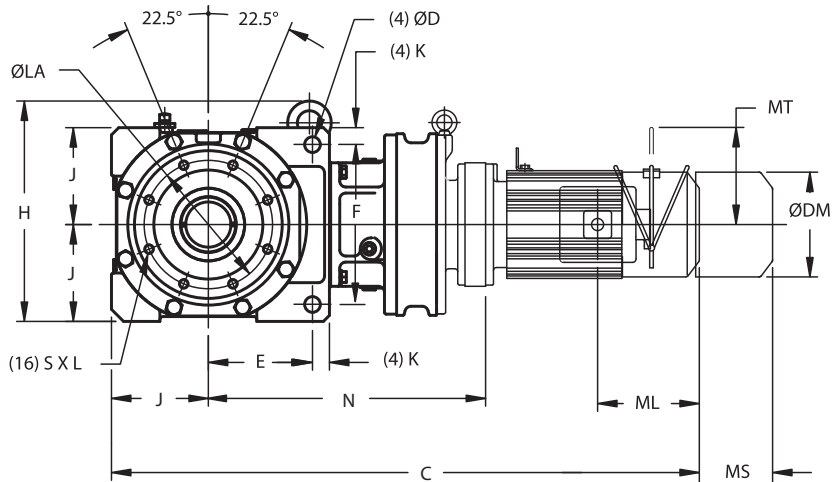
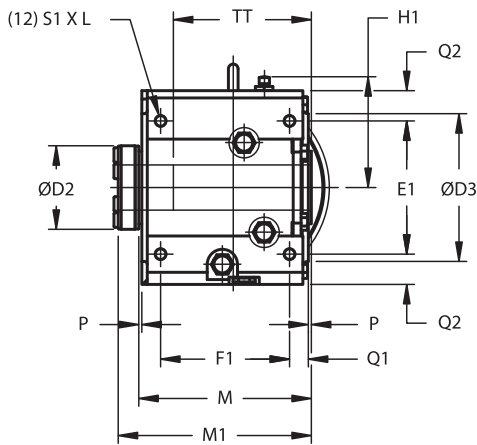
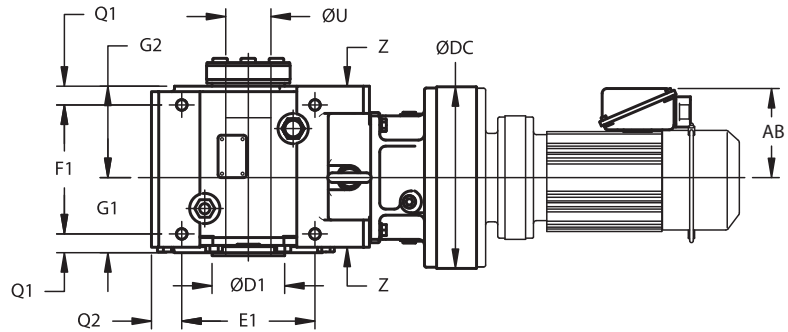
Dimensions

Dimensions shown are for reference only and are subject to change without notice, unless certified.  
 Certified prints are available after receipt of an order; consult factory.

# Dimensions

## Double Reduction LHYM-3D16DA~3E17DC

Min. Engagement	
FRAME SIZE	TT
3A	7.79
3B	9.33
3C	10.16
3D	11.82



All dimensions are in inches.

Model	N	ØDC	J	E	F	K	Z	ØD	E1	F1	Q1	Q2	S1 x L	M
3D16DA	20.24	11.81												
3D16DB	20.79	11.81												
3D16DC	20.87	11.81	7.48	7.60	12.21	1.38	2.17	1.30	9.84	10.00	1.42	2.56	M24x1.57	13.39
3D17DA	20.04	13.39												
3D17DB	20.59	13.39												
3D17DC	20.75	13.39												
3E17DA	21.02	13.39												
3E17DB	21.57	13.39	8.46	9.06	14.17	1.38	2.17	1.30	11.81	11.14	1.50	2.56	M24x1.57	14.69
3E17DC	21.73	13.39												

Model	P	G1	G2	H	H1	ØLA	ØD3	S x L	M1	ØD1	ØD2	ØU	
												Std & Max	Min
3D16DA													
3D16DB													
3D16DC	0.28	5.83	7.01	16.69	8.39	10.04	11.61	M20x1.30	15.00	5.51	5.98	3-7/16	2-7/16
3D17DA													
3D17DB													
3D17DC													
3E17DA													
3E17DB	0.28	6.14	7.99	19.61	9.37	11.02	12.60	M20x1.38	16.30	6.30	6.69	3-15/16	2-15/16
3E17DC													

Dimensions shown are for reference only and are subject to change without notice, unless certified.  
Certified prints are available after receipt of an order; consult factory.

## Double Reduction LHYM-3D16DA~3E17DC Dimensions

All dimensions are in inches.

Model	4 Pole Motor HP	Without Brake					With Brake						
		C	ØDM	AB	ML	W (lb)	C	ØDM	AB	ML	MS	MT	W (lb)
3D16DA	1/4	33.46	4.88	5.04	2.32	518	34.72	4.88	5.04	3.58	2.40	-	523
	1/3	33.46	4.88	5.04	2.32	518	34.72	4.88	5.04	3.58	2.40	-	523
	1/2	34.25	4.88	5.04	2.32	520	35.51	4.88	5.04	3.58	2.40	-	525
	3/4	35.87	5.83	5.63	3.82	529	37.56	5.83	5.63	5.51	3.66	4.17	536
	1	35.87	5.83	5.63	3.82	529	37.56	5.83	5.63	5.51	3.66	4.17	536
	1.5	37.17	6.30	5.83	3.94	538	39.61	6.30	5.83	6.38	4.53	4.49	549
	2	37.17	6.30	5.83	3.94	538	39.61	6.30	5.83	6.38	4.53	4.49	549
3D16DB	1.5	37.72	6.30	5.83	3.94	542	40.16	6.30	5.83	6.38	4.53	4.49	553
	2	37.72	6.30	5.83	3.94	542	40.16	6.30	5.83	6.38	4.53	4.49	553
	3	38.50	6.81	6.10	4.13	551	40.98	6.81	6.10	6.61	4.76	4.88	564
3D16DC	5	40.67	8.35	6.54	5.00	587	43.50	8.35	6.54	7.83	5.20	6.18	609
3D17DA	1/2	34.06	4.88	5.04	2.32	549	35.31	4.88	5.04	3.58	2.40	-	553
	3/4	35.67	5.83	5.63	3.82	558	37.36	5.83	5.63	5.51	3.66	4.17	564
	1	35.67	5.83	5.63	3.82	558	37.36	5.83	5.63	5.51	3.66	4.17	564
	1.5	36.97	6.30	5.83	3.94	564	39.41	6.30	5.83	6.38	4.53	4.49	576
	2	36.97	6.30	5.83	3.94	564	39.41	6.30	5.83	6.38	4.53	4.49	576
3D17DB	2	37.52	6.30	5.83	3.94	571	38.31	6.30	5.83	6.38	4.53	4.49	582
	3	39.96	6.81	6.10	4.13	580	40.79	6.81	6.10	6.61	4.76	4.88	593
3D17DC	3	38.46	6.81	6.10	4.13	610	40.95	6.81	6.10	6.61	4.76	4.88	606
	4	39.37	8.35	6.54	5.00	613	42.20	8.35	6.54	7.83	5.20	6.18	635
	5	39.37	8.35	6.54	5.00	613	42.20	8.35	6.54	7.83	5.20	6.18	635
3E17DA	1/4	36.42	4.88	5.04	2.32	710	37.68	4.88	5.04	3.58	2.40	-	714
	1/3	36.42	4.88	5.04	2.32	710	37.68	4.88	5.04	3.58	2.40	-	714
	1/2	37.20	4.88	5.04	2.32	712	38.46	4.88	5.04	3.58	2.40	-	717
	3/4	38.82	5.83	5.63	3.82	721	40.51	5.83	5.63	5.51	3.66	4.17	728
	1	38.82	5.83	5.63	3.82	721	40.51	5.83	5.63	5.51	3.66	4.17	728
	1.5	40.12	6.30	5.83	3.94	728	42.56	6.30	5.83	6.38	4.53	4.49	739
	2	40.12	6.30	5.83	3.94	728	42.56	6.30	5.83	6.38	4.53	4.49	739
3E17DB	1.5	40.67	6.30	5.83	3.94	734	43.11	6.30	5.83	6.38	4.53	4.49	745
	2	40.67	6.30	5.83	3.94	734	43.11	6.30	5.83	6.38	4.53	4.49	745
	3	43.11	6.81	6.10	4.13	743	43.94	6.81	6.10	6.61	4.76	4.88	756
3E17DC	3	41.61	6.81	6.10	4.13	754	44.09	6.81	6.10	6.61	4.76	4.88	770
	4	42.52	8.35	6.54	5.00	776	45.35	8.35	6.54	7.83	5.20	6.18	798
	5	42.52	8.35	6.54	5.00	776	45.35	8.35	6.54	7.83	5.20	6.18	798
	7.5	44.25	8.35	6.54	5.00	792	47.09	8.35	6.54	7.83	5.20	6.18	814

Gearmotors

Dimensions

Dimensions shown are for reference only and are subject to change without notice, unless certified.  
 Certified prints are available after receipt of an order; consult factory.

This page intentionally left blank.

Gearmotors



# 4

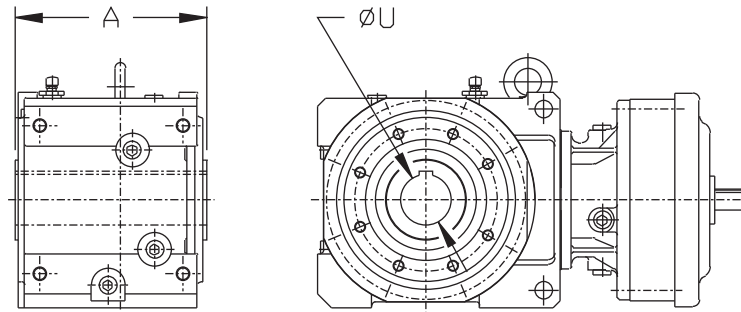
# Options

---

## Options

All dimensions are in inches. Dimensions shown are for reference only and are subject to change without notice, unless certified. Certified prints are available after receipt of an order; consult factory.

## Keyed Hollow Shaft



Frame Size	ØU	A	Keyway	TK*
3A	2.000	8.50	1/2 x 1/4	6.50
3B	2.375	10.20	5/8 x 5/16	7.87
3C	2.750	11.22	5/8 x 5/16	9.76
3D	3.250	13.39	3/4 X 3/8	11.93
3E	4.000	14.69	1 X 1/2	10.24

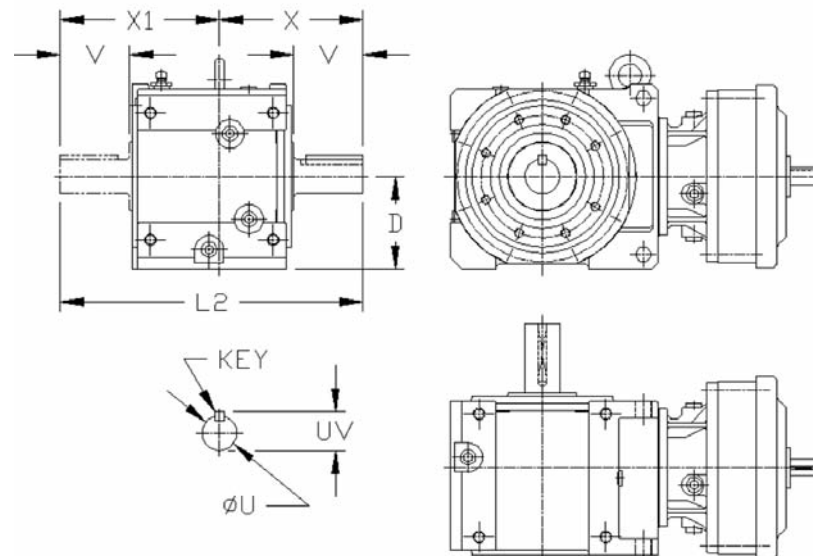
Frame Size	Available Bore Sizes			
	Inch		Metric (mm)	
	Min.	Max.	Min.	Max.
3A	1-3/4	2-3/16	45	55
3B	2-3/16	2-5/8	55	65
3C	2-7/16	3	60	75
3D	2-3/4	3-7/16	70	85
3E	3-3/16	4	80	100

\*Recommended minimum shaft engagement

Cyclo BBB

Options

## Solid Output Shaft



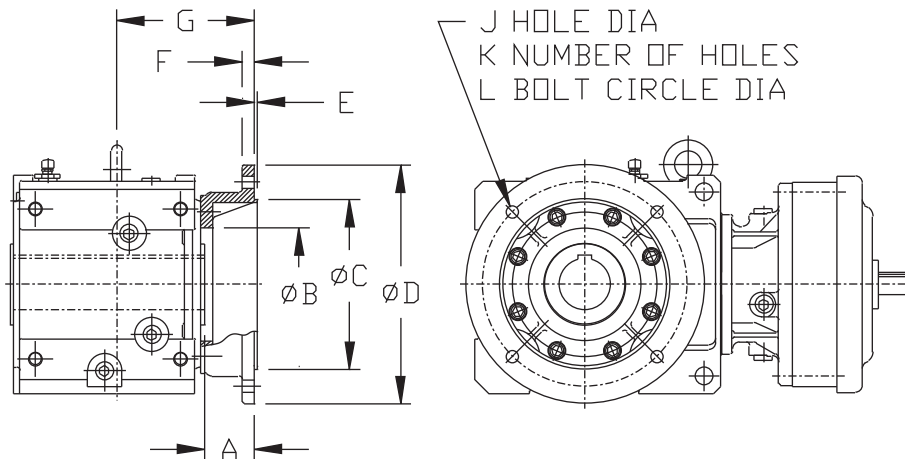
Frame Size	ØU	UV	D	V	X	Key	X1	L2
3A	2.000	2.22	4.33	3.54	7.48	1/2 x 1/2 x 2.76	8.11	15.59
3B	2.875	3.20	5.12	4.53	9.53	3/4 x 3/4 x 3.15	9.72	19.25
3C	3.125	3.45	6.30	5.71	10.79	3/4 x 3/4 x 4.72	11.85	22.64
3D	3.625	4.01	7.48	6.69	12.80	7/8 x 7/8 x 5.51	13.98	26.77
3E	4.375	4.82	8.46	7.87	14.29	1 x 1 x 6.30	16.14	30.43



All dimensions are in inches. Dimensions shown are for reference only and are subject to change without notice, unless certified. Certified prints are available after receipt of an order; consult factory.

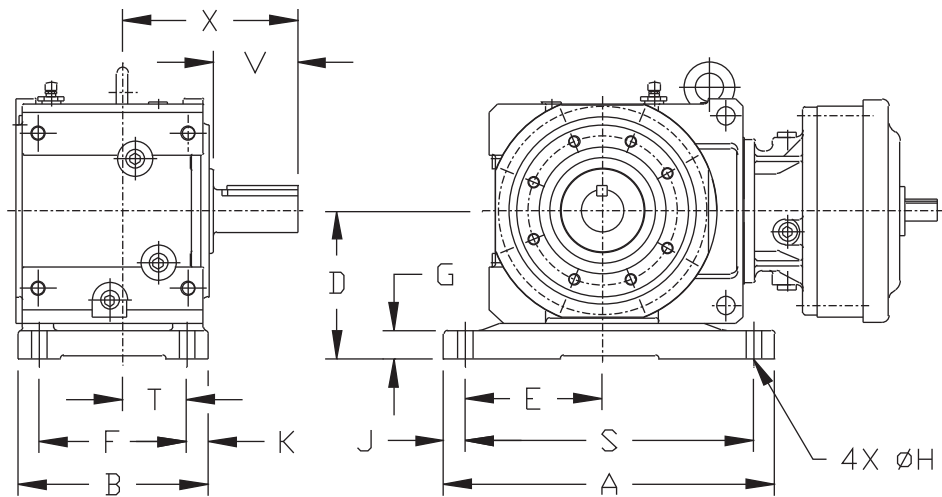
## Options

## Output Flange



Frame Size	A	B	C	D	E	F	G	J	K	L
3A	2.36	4.72	7.09	9.84	0.16	0.59	6.30	0.55	4	8.46
3B	2.40	5.51	9.06	11.81	0.16	0.63	7.40	0.55	4	10.43
3C	2.87	6.50	9.84	13.78	0.20	0.71	7.95	0.71	4	11.81
3D	3.15	7.68	13.78	17.72	0.20	0.87	9.25	0.71	8	15.75
3E	3.15	8.66	13.78	17.72	0.20	0.87	9.57	0.71	8	15.75

## Foot Mounted



Frame Size	A	B	D	E	F	G	H	J	K	S	T	V	X
3A	12.60	7.95	5.51	5.31	6.30	0.98	0.55	0.79	0.83	11.02	2.83	3.54	7.48
3B	15.16	9.65	6.69	6.30	7.68	1.38	0.71	0.79	0.98	13.58	3.74	4.53	9.53
3C	19.88	10.63	8.27	7.68	8.27	1.57	0.87	1.18	1.18	17.52	3.58	5.71	10.79
3D	22.05	12.60	9.65	9.25	10.24	1.77	1.02	1.18	1.18	19.69	4.53	6.69	12.80
3E	25.59	13.98	10.83	10.63	11.02	1.77	1.30	1.38	1.50	22.83	4.57	7.87	14.29

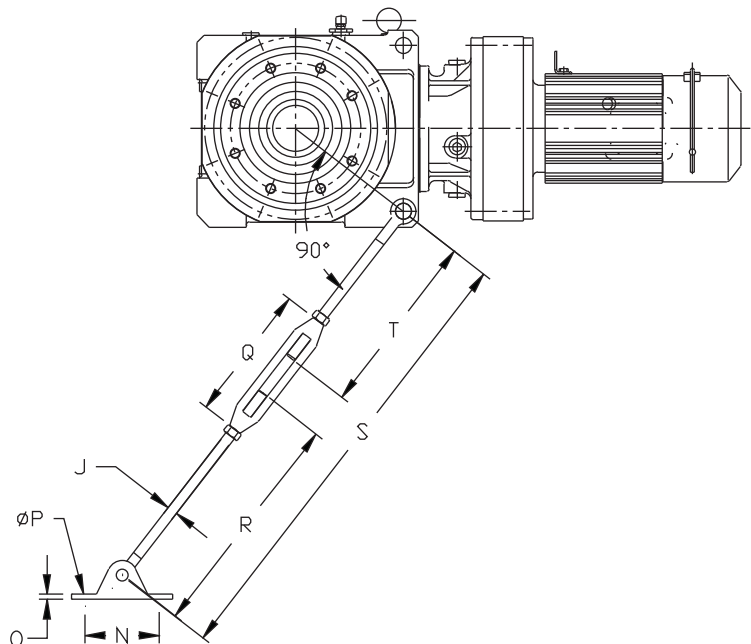
Cyclo BBB

Options

# Options

All dimensions are in inches. Dimensions shown are for reference only and are subject to change without notice, unless certified. Certified prints are available after receipt of an order; consult factory.

## Torque Arm TURNBUCKLE TYPE

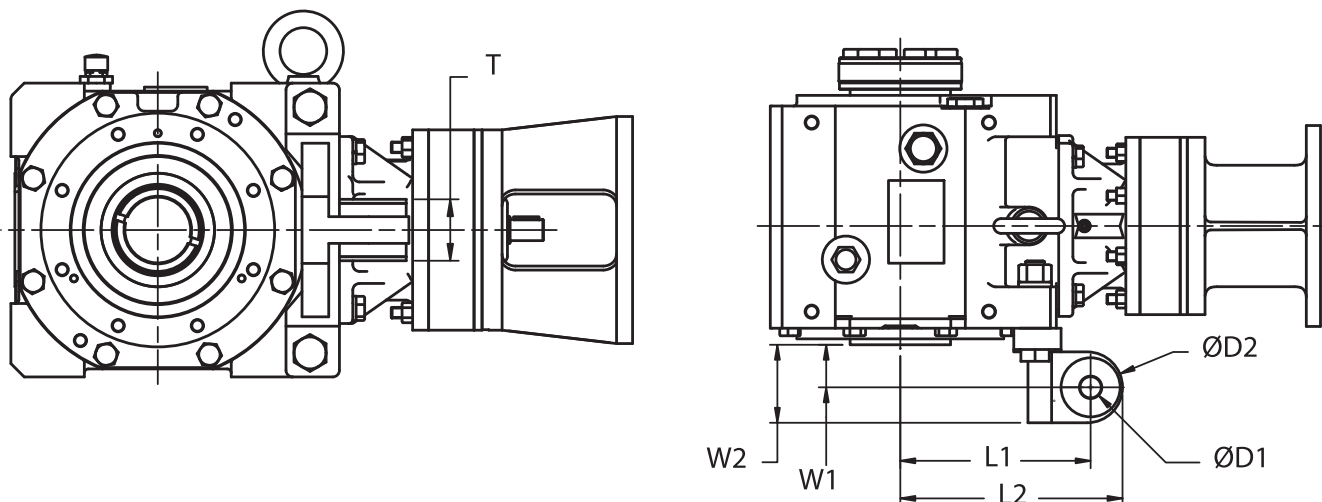


Turnbuckle Type										T-Type (optional)									
Frame Size	J	M	N	O	P	Q	R	S		T	Frame Size	L1	L2	W1	W2	T	ØD1	ØD2	Bolt Size
								Min	Max										
A	M20	0.71	3.94	0.47	0.63	8.50	14.76	25.20	31.10	10.43	A	6.34	7.40	1.42	2.60	1.81	0.71	2.36	M16
B	M20	0.87	3.94	0.47	0.63	8.50	14.76	25.79	31.69	11.02	B	7.68	8.98	1.89	3.31	2.05	0.87	2.83	M20
C	M24	1.02	4.72	0.71	0.63	8.74	14.76	26.57	32.48	11.81	C	9.13	10.79	2.40	4.17	2.20	1.02	3.54	M24
D	M24	1.30	4.72	0.71	0.63	8.74	14.76	27.95	33.86	13.19	D	10.98	12.95	2.91	5.08	2.44	1.30	3.94	M30
E	M24	1.30	4.72	0.71	0.63	8.74	14.76	27.95	33.86	13.19	E	12.05	14.21	2.91	5.08	2.44	1.30	4.33	M30

CycloBBB

Options

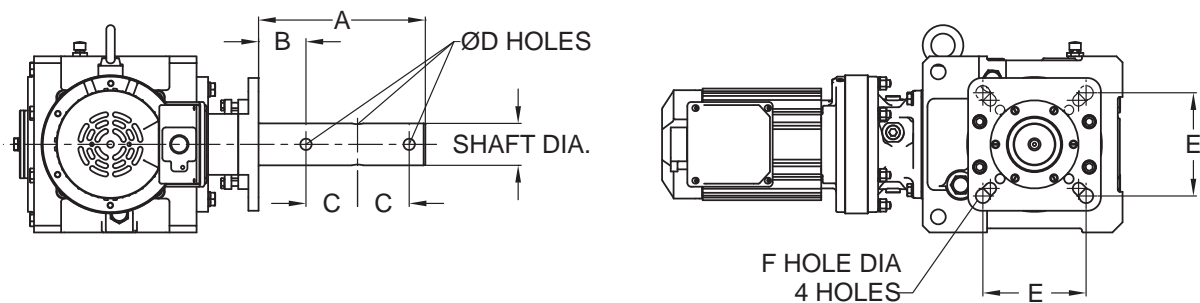
## Torque Arm T-Type (Optional)



All dimensions are in inches. Dimensions shown are for reference only and are subject to change without notice, unless certified. Certified prints are available after receipt of an order; consult factory.

# Options

## Screw Conveyor Drive



- Complete Cyclo® BBB screw conveyor drive consists of reducer, CEMA drive shaft assembly and mounting adapter kit. The CEMA drive shaft and mounting adapter kit require customer assembly.
- All Cyclo® BBB reducers used as screw conveyor drives require R1 high capacity bearings.
- CEMA drive shafts are three hole style.

All dimensions are in inches.

Model	Shaft Dia.	A	B	C	ØD	E <sup>[1]</sup>	F
3A, 3B	1-1/2	9	2.13	3	17/32	4	0.531
	2	9	2.13	3	21/32	5.13	0.669
	2-7/16	9.69	2.75	3	21/32	5.63	0.669
	3	9.88	2.88	3	25/32	6	0.827
3C, 3D	2	9	2.13	3	21/32	5.13	0.669
	2-7/16	9.69	2.75	3	21/32	5.63	0.669
	3	9.88	2.88	3	25/32	6	0.827
	3-7/16	13.13	3.88	4	29/32	6.75	0.827
3E	2-7/16	9.69	2.75	3	21/32	5.63	0.669
	3	9.88	2.88	3	25/32	6	0.827
	3-7/16	13.13	3.88	4	29/32	6.75	0.827

BBB Reducer Model	Drive Shaft Diameter (in.)	To Fit Screw Diameter (in.)	CEMA Steel Drive Shaft Assembly P/N	CEMA Stainless Drive Shaft Assembly P/N	Mounting Adapter Kit P/N
3A	1-1/2	6 - 9	118A4108-C3	-	118A4040
	2	9 - 12	118A4200-C3	-	
	2-7/16	12 - 14	118A4207-C3	-	
	3	12 - 20	118A4300-C3	-	
3B	1-1/2	6 - 9	118B4108-C3	-	118B4040
	2	9 - 12	118B4200-C3	-	
	2-7/16	12 - 14	118B4207-C3	118B4207-S3	
	3	12 - 20	118B4300-C3	118B4300-S3	
C	2	9 - 12	118C4200-C3	-	118C4040
	2-7/16	12 - 14	118C4207-C3	-	
	3	12 - 20	118C4300-C3	-	
	3-7/16	18 - 24	118C4307-C3	-	
D	2	9 - 12	118D4200-C3	-	118D4040
	2-7/16	12 - 14	118D4207-C3	-	
	3	12 - 20	118D4300-C3	-	
	3-7/16	18 - 24	118D4307-C3	-	
E	2-7/16	12 - 14	118E4207-C3	-	118E4040
	3	12 - 20	118E4300-C3	-	
	3-7/16	18 - 24	118E4307-C3	-	

Note: [1] The dimension shown is E maximum.

This page intentionally left blank.

# 5

# Appendix

---

# Special Load Guidelines Overhung Load

## Reducer/Gearmotor Allowable Overhung Load

When a sprocket, sheave, or gear is mounted on the slow speed shaft of a reducer, an overhung load is applied on that shaft. It is necessary to check if the shaft of the Cyclo BBB Speed Reducer will allow the overhung load. Calculate the overhung load using this formula:

$$\text{Overhung Load} = \frac{126,000 \times \text{HP} \times \text{Cf} \times \text{Lf} \times \text{Sf}}{D \times N}$$

LEGEND

- HP:** Horsepower transmitted by shaft
- Cf:** Load connection factor (Fig. 5.1)
- Lf:** Load location factor (Fig. 5.3 Output Shaft; Fig. 5.7 Input Shaft)
- Sf:** Service factor (Determine from Fig. 5.2 and "How to Select," pages 2.4 and 3.4)
- D:** Pitch diameter of sprocket, etc.
- N:** Shaft speed (rpm)

**Table 5.1 Load Connection Factor**

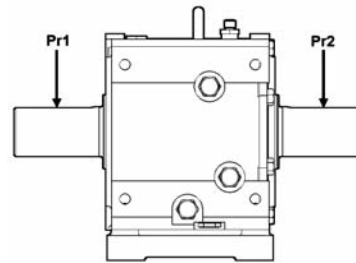
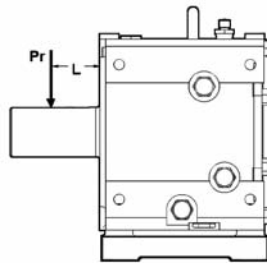
Type of Connection	Cf
General Purpose Chain	1.0
Machined Gear, Pinion or Synchronous Belt	1.25
V-Belt	1.5
Flat Belt	2.5

**Table 5.2 Service Factor**

Shock Factor	Sf
No Shock	1.0
Moderate Shock	1.5
Heavy Shock	2.0

**Figure 5.1 Centerline of Load, Output**

"L" indicates the distance from the hollow shaft end to the mid-point of the radial load.



For double extended output shafts, Pr1 + Pr2 must be less than the Allowable Overhung Load.

**Table 5.3 Overhung Load Location Factor of Output Shaft, Lf (Keyed Hollow Bore, Tapered Grip Bushing)**

Frame Size	L (inches)											
	1	1 1/4	1 1/2	1 3/4	2	2 1/2	3	3 1/2	4	4 1/2	5	6
3A100, 3A105, 3A110, 3A115, 3A120, 3A125, 3A140, 3A145,	1.04	1.08	1.12	1.16	1.19	1.27	1.35	1.42	-	-	-	-
3B120, 3B125, 3B140, 3B145, 3B160, 3B165	1.03	1.06	1.09	1.13	1.15	1.22	1.28	1.34	1.40	1.46	-	-
3C140, 3C145, 3C160, 3C165, 3C170, 3C175	1.02	1.06	1.08	1.11	1.14	1.20	1.25	1.31	1.37	1.42	1.48	-
3D160, 3D165, 3D170, 3D175,	1.02	1.05	1.07	1.09	1.11	1.16	1.21	1.26	1.31	1.35	1.39	1.49
3E170, 3E175	1.02	1.04	1.06	1.09	1.10	1.15	1.19	1.24	1.27	1.31	1.35	1.44

**Table 5.4 Allowable Overhung Load for Output Shaft (Keyed Hollow Bore, Tapered Grip Bushing) (Lf, Cf, Sf = 1) Unit: lbs.**

Frame Size	Output Shaft Speed (RPM)									
	5	10	20	30	35	45	50	60	75	90
3A100, 3A105, 3A110, 3A115, 3A120, 3A125, 3A140, 3A145,	1124	1124	1124	1124	1124	1124	1124	1124	1124	1124
3B120, 3B125, 3B140, 3B145, 3B160, 3B165	2068	2068	2068	2068	2068	2068	2068	2068	2068	2068
3C140, 3C145, 3C160, 3C165, 3C170, 3C175	3484	3484	3484	3484	3484	3484	3484	3484	3484	3215
3D160, 3D165, 3D170, 3D175,	4811	4811	4811	4811	4811	4811	4811	4811	4811	3799
3E170, 3E175	5170	5170	5170	5170	5170	5170	5170	5170	5170	5170

# Special Load Guidelines Overhung Load continued

Table 5.5 Overhung Load Location Factor, Lf (Solid Output Shaft)

Frame Size	L (inches)											
	1	1 1/4	1 1/2	1 3/4	2	2 1/2	3	3 1/2	4	4 1/2	5	6
3A100, 3A105, 3A110, 3A115, 3A120, 3A125, 3A140, 3A145,	0.87	0.91	0.90	1.00	1.14	1.42	1.70	1.98	–	–	–	–
3B120, 3B125, 3B140, 3B145, 3B160, 3B165	0.83	0.87	0.90	0.94	0.97	1.11	1.33	1.55	1.77	1.99	–	–
3C140, 3C145, 3C160, 3C165, 3C170, 3C175	0.81	0.84	0.86	0.89	0.91	0.97	1.09	1.27	1.45	1.64	1.82	–
3D160, 3D165, 3D170, 3D175,	0.79	0.82	0.84	0.87	0.89	0.94	0.98	1.12	1.27	1.43	1.59	1.91
3E170, 3E175	0.78	0.81	0.83	0.85	0.87	0.91	0.95	1.00	1.14	1.28	1.42	1.70

Table 5.6 Allowable Overhung Load for Output Shaft: (Solid Output Shaft) (Lf, Cf, Fs = 1)

Unit: lbs.

Frame Size	Output Shaft Speed (RPM)										
	5	10	20	30	35	45	50	60	75	90	
3A100, 3A105, 3A110, 3A115, 3A120, 3A125, 3A140, 3A145,	989	989	989	989	989	989	989	989	989	989	989
3B120, 3B125, 3B140, 3B145, 3B160, 3B165	1641	1641	1641	1641	1641	1641	1641	1641	1641	1641	1641
3C140, 3C145, 3C160, 3C165, 3C170, 3C175	2855	2855	2855	2855	2855	2855	2855	2855	2855	2855	2405
3D160, 3D165, 3D170, 3D175,	3934	3934	3934	3934	3934	3934	3934	3934	3934	3754	2788
3E170, 3E175	4114	4114	4114	4114	4114	4114	4114	4114	4114	4114	4114

Table 5.7 Input Shaft Load Location Factor

Single Reduction Frame Size	L (inch)											
	1/4	1/2	3/4	1	1 1/4	1 1/2	1 3/4	2	2 1/2	3	3 1/2	4
3A100, 3A105, 3A110, 3A115	0.93	1.09	1.52	2.03	–	–	–	–	–	–	–	–
3A120, 3A125 3B120, 3B125	–	0.87	1.10	1.43	1.77	2.12	–	–	–	–	–	–
3A140, 3A145 3B140, 3B145 3C140, 3C145	–	0.84	0.98	1.25	1.53	1.83	2.11	–	–	–	–	–
3B160, 3B165 3C160, 3C165 3D160, 3D165	–	0.94	0.97	1.06	1.22	1.36	1.51	1.66	–	–	–	–
3C170, 3C175 3D170, 3D175 3E170, 3E175	–	–	0.95	0.99	1.09	1.23	1.38	1.51	1.79	2.08	–	–

Figure 5.2

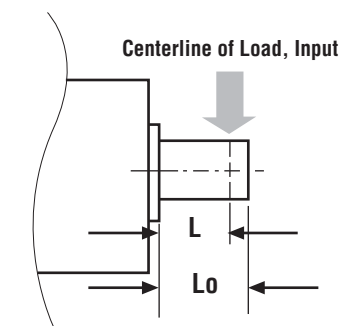


Table 5.8 Input Shaft Overhung Load Capacity (Lf, Cf, Sf = 1)

Unit: lbs.

Single Reduction Frame Size	Ratio	Input Speed RPM							
		1750	1450	1165	980	870	720	580	
3A100, 3A105	11~39, 60~417 46, 53	99	99	110	121	132	132	132	
		99	77	99	110	110	121	132	
3A110, 3A115	21, 28, 74~305 39~60	99	77	99	110	110	121	132	
		44	44	44	44	55	55	66	
3A120, 3A125 3B120, 3B125	21~60 74~305	133	155	166	175	198	198	198	
		121	99	110	121	133	198	198	
3A140, 3A145 3B140, 3B145 3C140, 3C145	21, 28 39~74 88 102~305	308	308	308	342	364	387	418	
		277	220	243	265	277	297	330	
		243	254	265	288	297	308	330	
3B160, 3B165 3C160, 3C165, 3D160, 3D165	28~88, 179, 207 102~151, 249, 305	398	398	441	463	486	486	486	
		243	265	288	308	308	353	398	
3C170, 3C175, 3D170, 3D175, 3E170, 3E175	39~305	463	463	508	508	528	551	596	

Cyclo BBB

Appendix

# Special Load Guidelines Inertia

**Table 5.9 Moment of Inertia on Motor Shaft of Gearmotor<sup>1</sup>**

Units: lb·inch<sup>2</sup>

Frame Size	Reduction Ratio								
	11	18	21	28	39	46	53	60	74
3A100, 3A105	1.53	0.636	0.461	0.301	0.175	0.162	0.141	0.101	0.104
3A110, 3A115	–	–	0.697	0.485	0.345	0.302	0.276	0.258	0.224
3A120, 3A125	3.59	1.48	1.23	0.960	0.584	0.619	0.581	0.434	0.489
3A140, 3A145	7.59	3.16	3.37	2.27	1.60	1.29	1.16	1.03	0.875
3B120, 3B125	4.99	2.00	1.59	1.16	0.690	0.697	0.636	0.479	0.520
3B140, 3B145	9.06	3.69	3.73	2.47	1.71	1.36	1.22	1.07	0.906
3B160, 3B165	23.0	9.67	8.78	6.08	4.00	3.62	3.28	2.80	2.58
3C140, 3C145	13.2	5.20	4.79	3.06	2.02	1.59	1.38	1.20	0.991
3C160, 3C165	27.2	11.2	9.84	6.70	4.31	3.86	3.45	2.93	2.67
3C170, 3C175	50.2	21.8	23.6	17.4	13.4	12.2	10.8	10.3	9.57
3D160, 3D165	38.6	15.3	12.7	8.3	5.16	4.44	3.90	3.28	2.90
3D170, 3D175	61.5	25.8	26.5	19.0	14.2	12.8	11.2	10.7	9.81
3E170, 3E175	76.9	31.3	30.3	21.2	15.4	13.6	11.8	11.1	10.1

Note: [1] Table 5.9 does not include the inertia of the integral motors. Total unit inertia is obtained by adding the reducer inertia to the motor inertia.

Frame Size	Reduction Ratio							
	88	102	123	151	179	207	249	305
3A100, 3A105	0.092	0.064	0.058	0.053	0.070	0.047	0.067	0.045
3A110, 3A115	0.214	0.206	0.196	0.191	0.185	0.183	0.181	0.179
3A120, 3A125	0.451	0.318	0.301	0.285	0.393	0.271	0.383	0.260
3A140, 3A145	0.813	0.745	0.718	0.673	0.656	0.653	0.639	0.632
3B120, 3B125	0.472	0.333	0.311	0.292	0.400	0.275	0.386	0.262
3B140, 3B145	0.834	0.759	0.728	0.680	0.660	0.660	0.639	0.636
3B160, 3B165	2.43	2.17	2.09	2.00	1.97	1.98	1.89	1.87
3C140, 3C145	0.892	0.803	0.759	0.701	0.677	0.670	0.649	0.639
3C160, 3C165	2.49	2.21	2.12	2.02	1.99	1.99	1.90	1.87
3C170, 3C175	9.19	8.75	8.58	8.37	8.27	8.17	8.13	8.10
3D160, 3D165	2.66	2.33	2.20	2.07	2.02	2.02	1.92	1.88
3D170, 3D175	9.37	8.89	8.65	8.44	8.31	8.20	8.17	8.10
3E170, 3E175	9.60	9.06	8.78	8.51	8.37	8.24	8.20	8.13

**Table 5.10 Moment of Inertia on Motor Shaft of 3-Phase Integral Motor**

Units: lb·inch<sup>2</sup>

1/8 HP x 4 Pole		1/4 HP x 4 Pole		1/3 HP x 4 pole		1/2 HP x 4 pole		3/4 HP x 4 pole		1 HP x 4 pole	
Standard	w/ Brake	Standard	w/ Brake	Standard	w/ Brake	Standard	w/ Brake	Standard	w/ Brake	Standard	w/ Brake
1.11	1.20	1.71	1.88	1.71	1.88	2.22	2.31	3.45	3.79	4.10	4.44
1/5 HP x 4 Pole		2 HP x 4 Pole		3 HP x 4 pole		5 HP x 4 pole		7.5 HP x 4 pole		10 HP x 4 pole	
Standard	w/ Brake	Standard	w/ Brake	Standard	w/ Brake	Standard	w/ Brake	Standard	w/ Brake	Standard	w/ Brake
6.32	7.11	7.28	8.03	11.4	12.7	29.0	32.7	39.0	42.7	91.6	104
15 HP x 4 Pole		20 HP x 4 Pole		25 HP x 4 pole		30 HP x 4 pole		40 HP x 4 pole		50 HP x 4 pole	
Standard	w/ Brake	Standard	w/ Brake	Standard	w/ Brake	Standard	w/ Brake	Standard	w/ Brake	Standard	w/ Brake
128	140	307	455	769	793	769	793	855	878	1053	1097

**Table 5.11 Moment of Inertia on Motor Shaft of 3 Phase, Inverter Duty, Integral Motor**

Units: lb·inch<sup>2</sup>

1/8 HP x 4 Pole		1/4 HP x 4 Pole		1/2 HP x 4 pole		1 HP x 4 pole		2 HP x 4 pole		3 HP x 4 pole	
Standard	w/ Brake	Standard	w/ Brake	Standard	w/ Brake	Standard	w/ Brake	Standard	w/ Brake	Standard	w/ Brake
1.71	1.88	2.22	2.31	4.10	4.44	7.28	8.03	11.4	12.7	29.0	32.7
5 HP x 4 Pole		7.5 HP x 4 Pole		10 HP x 4 pole		15 HP x 4 pole		20 HP x 4 pole		25 HP x 4 pole	
Standard	w/ Brake	Standard	w/ Brake	Standard	w/ Brake	Standard	w/ Brake	Standard	w/ Brake	Standard	w/ Brake
39.0	42.7	91.6	104	128	140	307	455	769	-	769	793
30 HP x 4 Pole		40 HP x 4 Pole									
Standard	w/ Brake	Standard	w/ Brake								
855	878	1053	1097								

Cyclo BBB

Appendix



# Special Load Guidelines **Inertia** continued

Table 5.12 Moment of Inertia on High Speed Shaft of Reducer

Units: lb·inch<sup>2</sup>

Frame Size	Reduction Ratio								
	11	18	21	28	39	46	53	60	74
<b>3A100, 3A105</b>	1.54	0.649	0.482	0.281	0.196	0.140	0.120	0.125	0.083
<b>3A110, 3A115</b>	—	—	0.718	0.506	0.366	0.323	0.296	0.279	0.244
<b>3A120, 3A125</b>	3.62	1.54	1.35	0.841	0.704	0.499	0.461	0.554	0.369
<b>3A140, 3A145</b>	7.76	3.33	3.73	2.55	1.86	1.51	1.37	1.26	1.09
<b>3B120, 3B125</b>	5.06	2.06	1.71	1.04	0.810	0.578	0.520	0.598	0.400
<b>3B140, 3B145</b>	9.23	3.86	4.07	2.76	1.97	1.59	1.43	1.30	1.12
<b>3B160, 3B165</b>	31.3	18.0	12.9	10.1	8.03	7.66	7.31	6.84	6.63
<b>3C140, 3C145</b>	13.4	5.37	5.13	3.35	2.28	1.81	1.60	1.43	1.20
<b>3C160, 3C165</b>	35.5	19.6	13.9	10.7	8.34	7.90	7.49	6.97	6.70
<b>3C170, 3C175</b>	57.4	29.2	28.0	21.8	17.7	16.5	15.1	14.7	13.8
<b>3D160, 3D165</b>	46.8	27.1	16.7	12.3	9.16	8.48	7.93	7.31	6.94
<b>3D170, 3D175</b>	69.0	33.3	30.8	23.4	18.6	17.2	15.6	15.0	14.1
<b>3E170, 3E175</b>	84.4	39.0	34.5	25.6	19.8	18.0	16.2	15.5	14.4

Frame Size	Reduction Ratio								
	88	102	123	151	179	207	249	305	
<b>3A100, 3A105</b>	0.071	0.085	0.079	0.074	0.049	0.068	0.046	0.066	
<b>3A110, 3A115</b>	0.234	0.227	0.217	0.211	0.205	0.204	0.201	0.200	
<b>3A120, 3A125</b>	0.332	0.438	0.420	0.407	0.275	0.390	0.265	0.379	
<b>3A140, 3A145</b>	1.04	0.964	0.937	0.882	0.875	0.872	0.855	0.851	
<b>3B120, 3B125</b>	0.352	0.451	0.431	0.414	0.280	0.393	0.267	0.383	
<b>3B140, 3B145</b>	1.06	0.978	0.947	0.889	0.878	0.878	0.858	0.851	
<b>3B160, 3B165</b>	6.46	6.19	6.12	6.02	6.02	6.02	5.91	5.91	
<b>3C140, 3C145</b>	1.11	1.03	0.978	0.909	0.892	0.889	0.865	0.855	
<b>3C160, 3C165</b>	6.53	6.25	6.15	6.05	6.02	6.02	5.95	5.91	
<b>3C170, 3C175</b>	13.6	13.1	12.9	12.7	12.6	12.5	12.5	12.4	
<b>3D160, 3D165</b>	6.70	6.36	6.22	6.02	6.05	6.05	5.95	5.91	
<b>3D170, 3D175</b>	13.7	13.2	13.0	12.7	12.6	12.5	12.5	12.4	
<b>3E170, 3E175</b>	13.9	13.4	13.1	12.8	12.7	12.5	12.5	12.4	

## Special Load Guidelines Misc.

### Excessive Overloads

Cyclo BBB Speed Reducers provide 300% momentary intermittent shock load capacity and are warranted for 2 years from date of shipment. Refer to our standard terms and conditions for our complete warranty.

### Selection for Applications Involving Shock Loading

For applications involving frequent start-stop, braking or reversing, or quick starting of load having large inertia, consult factory for model selection or recommended modifications.

### Allowable Radial and Thrust Loads

The loads imposed on the slow speed shaft vary with the method of connecting the shaft to the driven machine. Frequently, in addition to torsional forces, radial

and thrust loads are applied to the slow speed shaft at the same time. For example, coupling connections normally involve torsional forces only. However, when power is transmitted through spur gears, belts, pulleys or chains, both torsional and radial forces may be applied to the slow speed shaft. When driving through helical or bevel gears, all three conditions (torsional, radial and thrust load) may be referred to the reducer shaft.

The slow speed shaft and bearings must have sufficient strength to withstand these loads, and it is, therefore, necessary to determine the allowable limits for each condition.

### Load Centering

The radial load capacities are calculated with the load concentrated at the midpoint of the slow speed shaft extension. Radial load capacities decrease if the center of the load is moved farther from the reducer and the values obtained from the charts must be adjusted accordingly.

# Taper Grip® Bushing

## Introduction

The keyless Taper-Grip® bushing system provides simple and reliable shaft attachment for Sumitomo Speed reducers and gearmotors. This system allows bi-directional shaft rotation and stop-start operation with a powerful, slip-free grip. To assure peak performance of your equipment, please read, understand and follow these installation instructions.

## Safety

Disconnect all power sources from the equipment before beginning this installation procedure. Handle the components with care and avoid all sharp or machined edges to prevent personal injury or damage to the components.

## Before Installing Unit on Driven Shaft (Steps 1-7)

Carefully inspect the driven equipment shaft. Remove all burrs, corrosion, lubricants, and foreign matter from the shaft surface. Verify the shaft diameter is within the dimensional tolerances shown in Table 5.13.

**Table 5.13 Driven Shaft Tolerances**

Shaft Diameter (inches)	Shaft Tolerance (inches)
3/4" – 1-1/8"	+0" – 0.005"
1 3/16" – 2"	+0" – 0.006"
2 1/16" – 3-1/8"	+0" – 0.007"
3 3/16" – 4-3/4"	+0" – 0.008"
4 13/16" – 6-1/2"	+0" – 0.009"

Clean all surfaces of the shaft, the bushing, the thrust collar and the unit bore with solvent to remove all grease and oil.

**Step 1** – Remove the Taper-Grip® bushing safety cover.

**Step 2** – Remove the cap screws from the bushing. Lightly oil the threads of the cap screws and partially re-insert them into the threaded holes in the bushing flange. The ends of the cap screws should not extend beyond the rear face of the bushing flange.

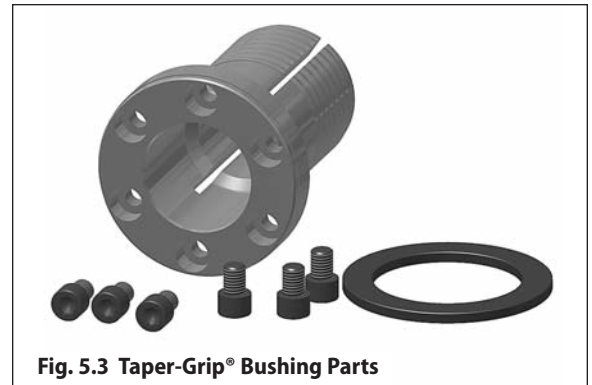
**Step 3** – Slide the thrust collar onto the Taper-Grip® bushing (see Fig. 5.4).

**Step 4** – Apply a thin layer of anti-seize paste **to the male threads of the Taper-Grip® Bushing only** (see Fig.5.5). Ensure that anti-seize paste does not enter the Taper-Grip® Bushing bore. **Caution: Do not apply anti-seize paste to the female threads in the hub.**

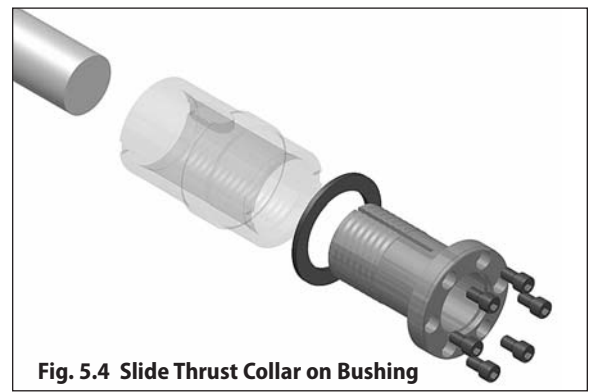
**Step 5** – Carefully thread the Taper-Grip® bushing into the hub of the speed reducer or gearmotor until the thrust collar solidly engages the unit hub surface and the bushing flange (see Fig. 5.6). **Caution: Do not cross-thread. Bushing should thread easily into hub.**

**Step 6** – Unscrew the Taper-Grip® bushing to create a 1mm (0.04") gap between the thrust collar and the bushing flange.

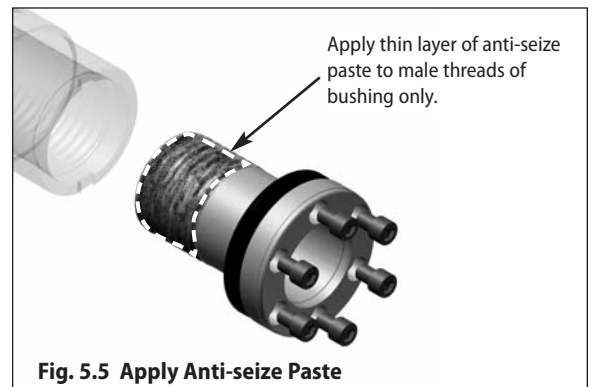
**Step 7** – Hand-tighten the cap screws until they firmly press the thrust collar against the unit hub surface. The unit is ready for installation on the driven shaft.



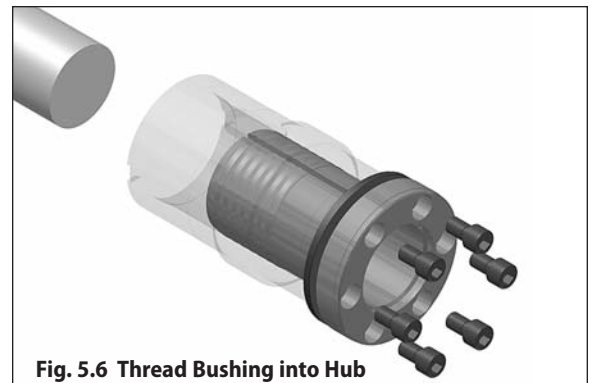
**Fig. 5.3 Taper-Grip® Bushing Parts**



**Fig. 5.4 Slide Thrust Collar on Bushing**



**Fig. 5.5 Apply Anti-seize Paste**



**Fig. 5.6 Thread Bushing into Hub**

# Taper Grip® Bushing continued

## Unit Installation

**Step 8** – Position unit with the bushing flange located on the outboard side of the unit. Align the bushing with the driven shaft. Slide the unit onto the driven shaft as close to the driven shaft support bearing as possible. Ideally, the driven shaft should extend beyond the bushing flange face (see Fig. 5.8). Refer to Fig. 5.7 and Table 5.14 below for minimum shaft to bushing engagement.

**Table 5.14 Minimum Shaft to Bushing Engagement**

BBB Model	Minimum Shaft Engagement	
	mm	inches
A	208	8.19
B	242	9.53
C	279	10.98
D	326	12.83
E	359	14.13

**Step 9** – With a torque wrench, gradually tighten the capscrews in 20% increments to engage the bushing system. Use the appropriate tightening pattern ("star-pattern" see Fig. 5.8) to assure complete bushing engagement. Tighten each capscrew to the torque values shown in Table 5.15:

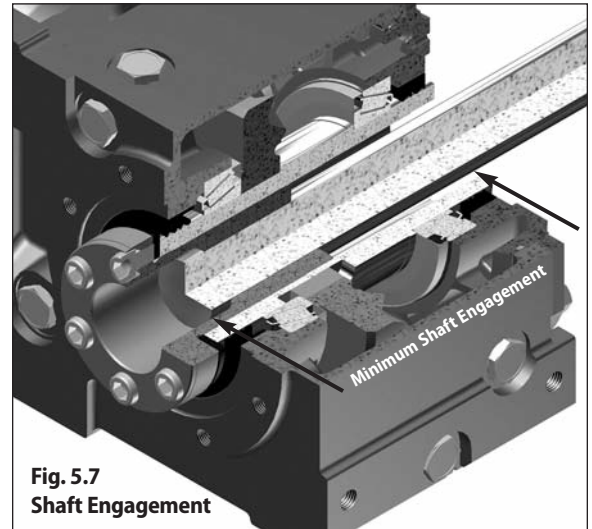
**Table 5.15 Capscrew Tightening Torques**

BBB Model	Capscrews (JIS Grade 12.9)		Capscrew Torque	
	Qty.	Size	Nm	Lb.Ft.
A	6	M12x16	75	56
B	6	M12x16	140	104
C	6	M16x20	250	185
D	6	M16x20	250	185
E	8	M16x20	250	185

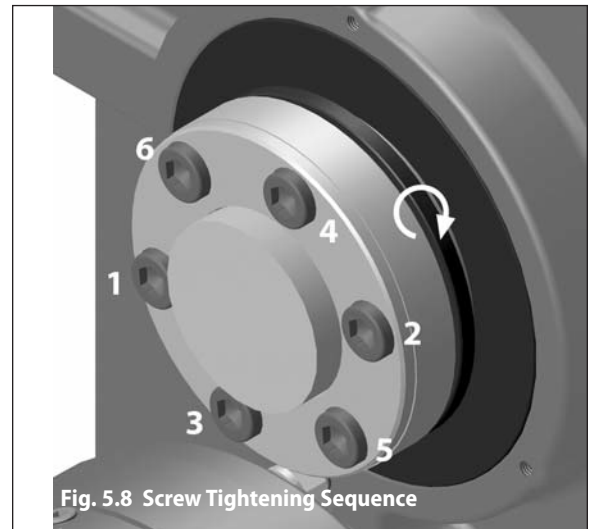
If the shaft is recessed in the bushing, fill the void with grease to prevent corrosion and fouling.

**Step 10** – Install the Taper-Grip® bushing safety cover.

**Step 11** – Please read, understand and follow the instructions shown in the reducer/gearmotor installation and operating manual to complete the unit installation and attach the torque arm.



**Fig. 5.7**  
Shaft Engagement



**Fig. 5.8** Screw Tightening Sequence

Cyclo BBB

# Taper Grip® Bushing continued

## Removal Procedure

**Step 1** – Remove the Taper-Grip® bushing safety cover.

**Step 2** – Before removing the reducer/gearmotor from the driven shaft, externally support the unit so that all its weight is removed from the driven shaft (see Fig. 5.9). **Caution: Do not raise the unit too high. It may cause the shaft to bind.**

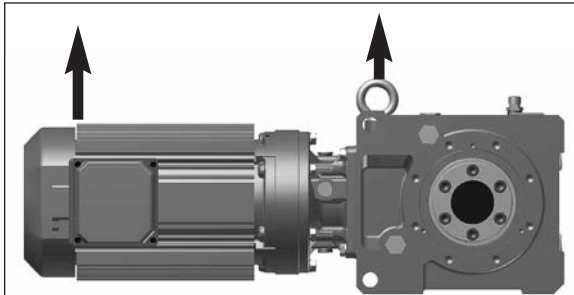


Fig. 5.9 Externally Support the Unit

**Step 3** – Check the Taper-Grip® Bushing to assure that there is a gap between the thrust collar and the bushing flange. If no gap exists, unit removal may be difficult (see Fig 5.10).

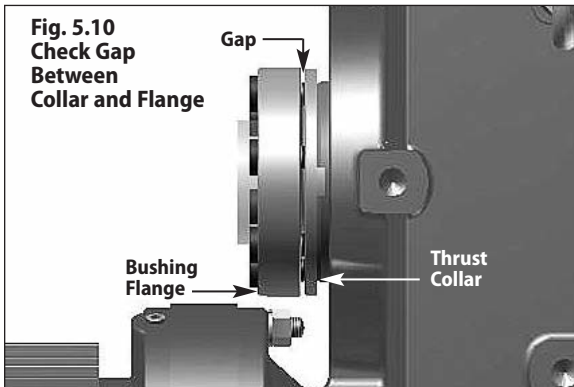


Fig. 5.10 Check Gap Between Collar and Flange

**Step 4** – Spray a liquid penetrant onto each of the Taper-Grip® Bushing capscrews. Allow time for the penetrant to settle into the threads of the capscrews. (see Fig 5.11).

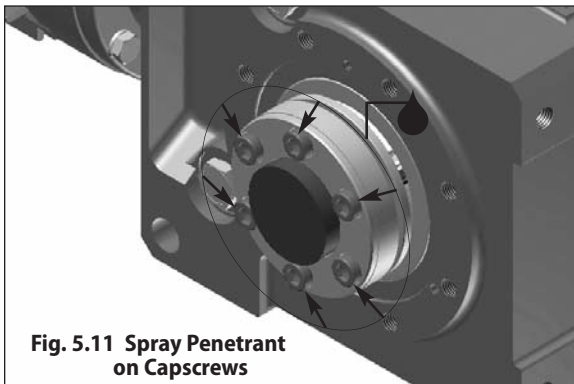


Fig. 5.11 Spray Penetrant on Capscrews

**Step 5** – After the liquid penetrant has been allowed to settle, remove the capscrews one at a time (see Fig 5.12).

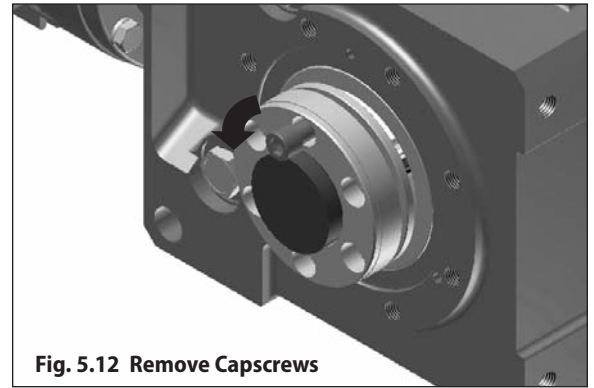


Fig. 5.12 Remove Capscrews

**Step 6** – Place a copper or brass bar against the flange of the Taper-Grip® Bushing and carefully strike end of bar with a hammer to release bushing (see Fig 5.13).

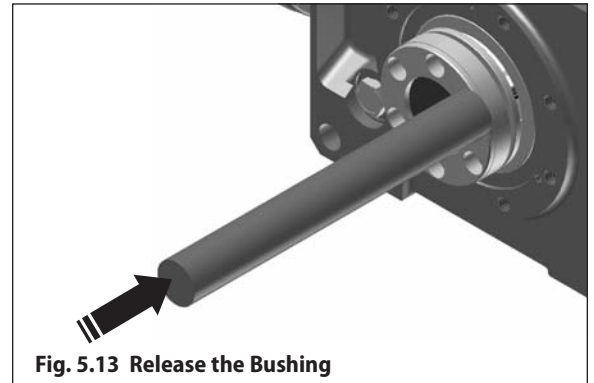


Fig. 5.13 Release the Bushing

**Step 7** – After releasing the bushing, apply a liquid penetrant to the shaft where it contacts the bushing. Allow time for the liquid to penetrate between the bushing and the shaft, then carefully slide the unit off of the shaft. (see Fig 5.14). **Note: If the bushing releases, but the unit cannot be removed from the shaft, apply a puller to the bushing to push the shaft free.**

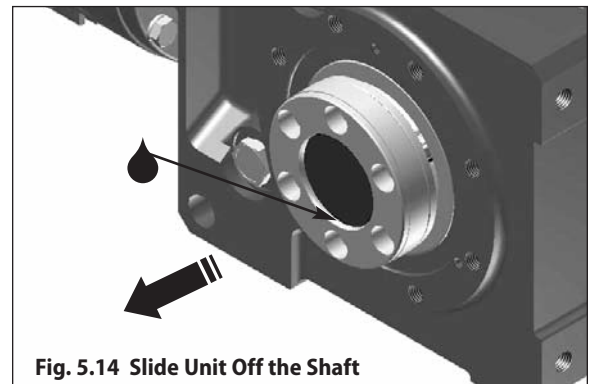


Fig. 5.14 Slide Unit Off the Shaft

Cyclo BBB

Appendix

# Installation

### Shaft Connections

*Pulley, sprocket or sheave connection* – When using any of these connections, mount as close to the unit housing as possible, never beyond the midpoint of the shaft projection, to avoid undue bearing load and shaft deflection. Never overtighten belts or chains. Careful and accurate installation is essential for best results and for trouble-free operation. Before installing, the shafts should be checked to make sure that they are parallel and level. Perfect alignment after mounting can be checked with a string or straight edge held against the sides of the sprocket or pulley base.

Couplings should be properly aligned to the limits specified by the manufacturer. On coupled speed reducers coupling alignment should be checked prior to initial startup.

### Cyclo® BBB Keyed Hollow Shaft Driven Shaft Tolerances

**Table 5.16 Uniform Load Without Shock Load**

Frame Size	Inch			Metric (mm)		
	Shaft Dia. Min.	Shaft Dia. Max.	Tolerance	Shaft Dia. Min.	Shaft Dia. Max.	Tolerance
3A	1-3/4	1-15/16	+0 / -0.0006	45	50	+0 / -0.016
	2	2-3/16	+0 / -0.0007	51	55	+0 / -0.019
3B	2-3/16	2-5/8	+0 / -0.0007	55	65	+0 / -0.019
3C	2-7/16	3	+0 / -0.0007	60	75	+0 / -0.019
3D	2-3/4	3-1/8	+0 / -0.0007	70	80	+0 / -0.019
	3-3/16	3-7/16	+0 / -0.0009	81	85	+0 / -0.022
3E	3-3/16	3-15/16	+0 / -0.0009	80	80	+0 / -0.019
				81 - 100	81 - 100	+0 / -0.022

**Table 5.17 With Shock Load or Large Radial Load**

Frame Size	Inch			Metric (mm)		
	Shaft Dia. Min.	Shaft Dia. Max.	Tolerance	Shaft Dia. Min.	Shaft Dia. Max.	Tolerance
3A	1-3/4	1-15/16	+0.0007/+0.0001	45	50	+0.018/+0.002
	2	2-3/16	+0.0008/+0.0001	51	55	+0.021/+0.002
3B	2-3/16	2-5/8	+0.0008/+0.0001	55	65	+0.021/+0.002
3C	2-7/16	3	+0.0008/+0.0001	60	75	+0.021/+0.002
3D	2-3/4	3-1/8	+0.0008/+0.0001	70	80	+0.021/+0.002
	3-3/16	3-7/16	+0.0010/+0.0001	81	85	+0.025/+0.003
3E	3-3/16	3-15/16	+0.0010/+0.0001	80	80	+0.021/+0.002
				81 - 100	81 - 100	+0.025/+0.003

### Shaft Rotation

On single reduction Cyclo BBB speed reducers, ratios 11 through 305, the slow speed shaft rotates in a reverse direction to that of the high speed shaft.

On double reduction units, ratios 357 through 26,492, both the high speed and the slow speed shaft rotate in the same direction.

### Input Speeds

In general terms, the standard input speeds of single reduction units are 1750 and 1165 RPM.

When non-standard input speeds are used, the horsepower and torque ratings will also vary.

### Thermal Capacity

The Cyclo BBB speed reducer's smooth, almost frictionless operation all but eliminates the conventional limitations due to heat. In all sizes, Cyclo BBB speed reducers have thermal ratings that exceed their mechanical capacity.

### Mounting Tips

Horizontal and vertical oil-lubricated units should be mounted in exact planes whenever possible. When they are mounted on inclined surfaces, minor modifications are necessary, since an inclined mounting could lower the oil to a level that will starve reduction parts and bearings. On the other hand, overfilling a unit with oil may cause leakage through the air vent, foaming and churning and

consequently overheating. Any of the above could result in damage to the unit. In many cases we can provide grease lubrication to solve this problem.

### Installation

Be sure to install and operate Cyclo BBB speed reducers in compliance with applicable local and national safety codes. Appropriate guards for rotating shafts should be used and are available from local stocks.

### Dimensions

All dimensions in this catalog are for reference purposes only. Consult factory for certified dimensions.

## Installation: Keyed Hollow Shaft

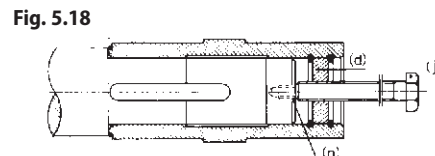
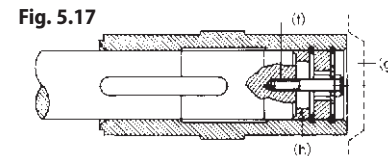
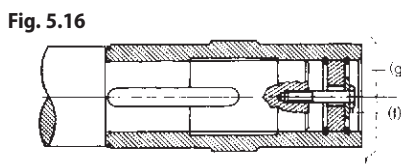
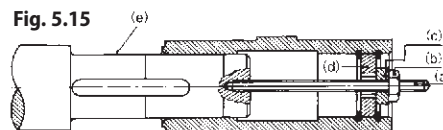
### Mounting procedure:

1. Smear the surface of the shaft (e) with molybdenum disulfide compound. See Fig. 5.15.
  2. Turn nut (b) and slide the reducer over the driven shaft. Install spacer (c) if necessary.
  3. After mounting the reducer on the shaft, install bolt (f) and washer. See Fig. 5.16.
- NOTE:** The bore should be protected by a cover (g).
4. If the driven shaft does not have a shoulder, a spacer (h) should be used. See Fig. 5.17.

### Removal procedure:

1. Remove mount bolt (n). Attach bolt (j) to spacer (d) and turn bolt (j) to remove the hollow shaft from the driven shaft. See Fig. 5.18.

**NOTE:** Parts a through j and n are not provided by Sumitomo.

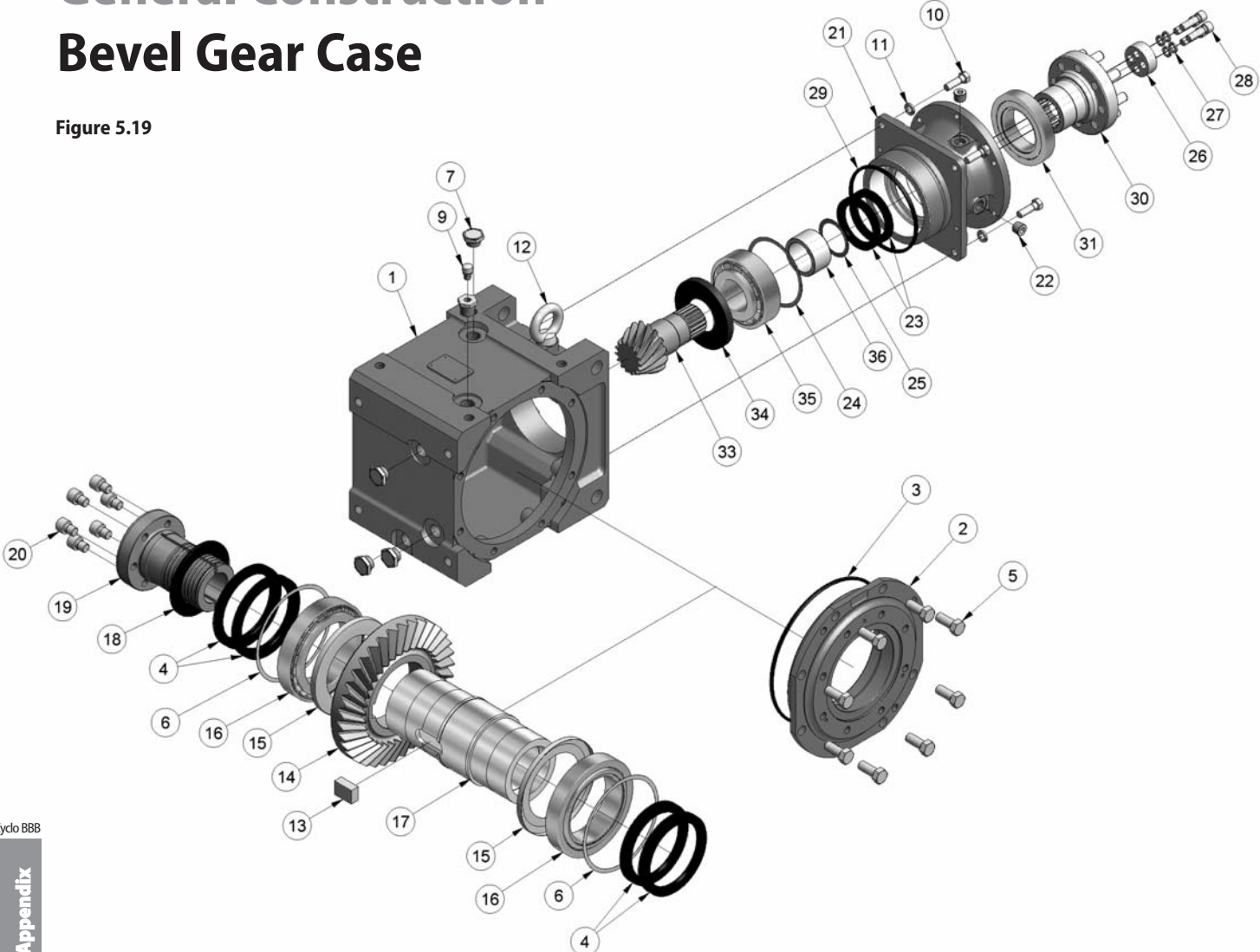




# Parts List

## General Construction Bevel Gear Case

Figure 5.19



Cyclo BBB

Appendix

Parts List continued

Table 5.18 Parts Code Numbers

Unit Size

Item No.	Description	QTY	A	B	C	D	E
1	Gear Housing	1	AE983LG	AE984LG	AE985LG	AE986LG	AE987LG
2	Output Cover	1	BL520LG	BL531LG	BL542LG	BL550LG	BL554LG
3	O-Ring	1	540NG1701-A-G	540NG2101-A-G	540NG2601-A-G	541N5.7-3258G	541N5.7-3757G
4	Oil Seal	4	531N8511013-G	531N10012513G	531N12015014G	531N14017014G	531N16019016G
5	Hex Head Bolt	8	001M010R030NG	001M012R030NG	001M016R040NG	001M020R050NG	001M020R050NG
6[2]	Shim	Varies	As required	As required	As required	As required	As required
7	Plug	8	343C008R- --NG	343C008R- --NG	343C012R- --NG	343C012R- --NG	343C012R- --NG
9	Air Vent	1	DT206LG	DT206LG	DT206LG	DT206LG	DT206LG
10	Hex Head Bolt	4	001M010R030NG	001M010R030NG	001M012R040NG	001M016R050NG	001M016R050NG
11	Spring Washer	4	062W010- ---NG	062W010- ---NG	062W012- ---NG	062W016- ---NG	062W016- ---NG
12	Eye Bolt	1	006C016R- --NG	006C016R- --NG	006C020R- --NG	006C020R- --NG	006C024R- --NG
13	Key	1	233M2214021NG	233M2514028NG	233M2816040NG	233M3218050NG	233M3620060NG
14	Bevel Gear	1	AP0646G	AP0647G	AP0648G	AP0649G	AP0650G
15	Nilos Ring	2	50532017XAV-G	50532020XAV-G	50532024XAV-G	50532028XAV-G	50532032XAV-G
16	Tapered Roller Bearing	2	503T32017XU-G	503T32020XU-G	503T32024XU-G	503T32028XU-G	503T32032XU-G
17	Taper-Grip® Output Hub	1	BL937LG	BL938LG	BL939LG	BL940LG	BL941LG
18[3]	Thrust Plate	1	—	—	—	—	—
19	Taper-Grip® Bushing	1	As required	As required	As required	As required	As required
20[3]	Taper-Grip® Bushing Screws	Varies	—	—	—	—	—
21[4]	Flanged Casing	1	As required	As required	As required	As required	As required
22	Hex Socket Plug	Varies	As required	343C008R- --NG	343C008R- --NG	343C008R- --NG	343C008R- --NG
23	Oil Seal	2	530N50689- --G	530N60759- --G	530N709513- --G	530N9011513-G	530N9011513-G
24[2]	Shim	Varies	As required	As required	As required	As required	As required
25[2]	Shim	Varies	As required	As required	As required	As required	As required
26	End Plate	1	AW7028G	AW7030G	AW7032G	As required	AW7036G
27	Lock Washer	4	EU593WW-05	EU593WW-05	EU593WW-07	As required	EU593WW-09
28	Hex. Soc. Hd. Cap Screw	4	009M008R030NG	009M010R035NG	009M012R040NG	As required	009M016R055NG
29	O-Ring	1	540NG1101-A-G	540NG1301-A-G	540NG1501-A-G	540NG1751-A-G	540NG1851-A-G
30[5]	Pin Carrier	1	As required	As required	As required	As required	As required
31	Tapered Roller Bearing	1	As required	As required	As required	As required	As required
33	Bevel Pinion Shaft	1	BL513LG	BL525LG	BL536LG	As required	BL553LG
34	Nilos Ring	1	50532308AV- --G	50532310AV- --G	50532312AV- --G	50532314AV- --G	50532315AV- --G
35	Tapered Roller Bearing	1	503T32308U- --G	503T32310U- --G	503T32312U- --G	503T32314U- --G	503T32315U- --G
36	Collar	1	AW7027G	AW7029G	AW7031G	As required	AW7034G

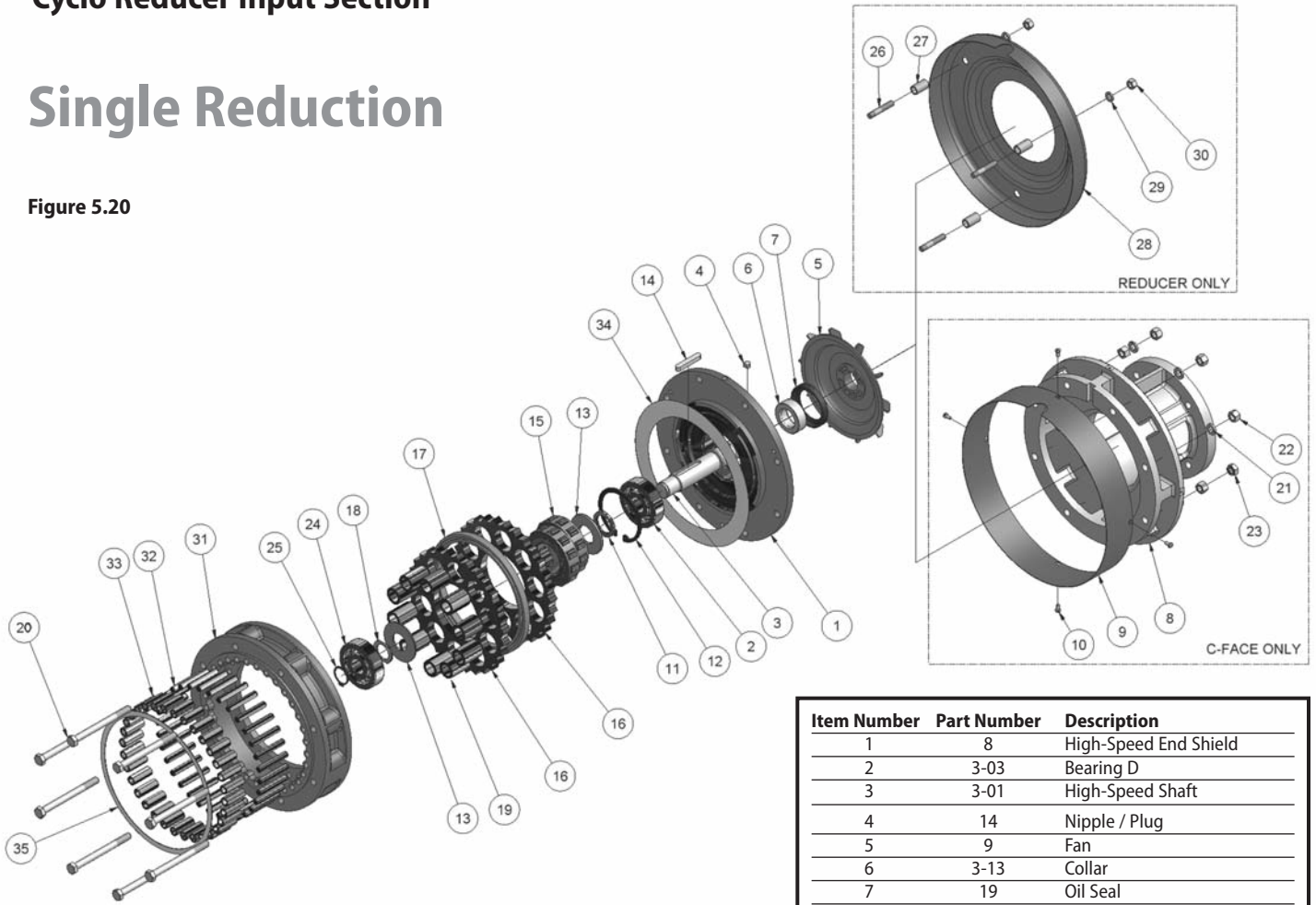
- Notes:** [1] When ordering replacement parts, please indicate the complete unit model number, ratio and serial number.  
[2] Shims are not available individually. They may be ordered as a complete set only.  
[3] Item Numbers 18 and 20 are not available as individual parts. They come complete with the Taper-Grip® Bushing.  
[4] The Flange Casing is determined based on the associated input Cyclo size.

# Cyclo Parts List

## Cyclo Reducer Input Section

### Single Reduction

Figure 5.20



**Table 5.19 Single Reduction Input Section Main Parts**

Item Number	Part Number	Description
1	8	High-Speed End Shield
2	3-03	Bearing D
3	3-01	High-Speed Shaft
4	14	Nipple / Plug
5	9	Fan
6	3-13	Collar
7	19	Oil Seal
8	—	"C" Face Motor Adapter
9	—	Fan Shroud
10	—	Shroud Bolts/Screws
11	3-08	Spacer
12	3-11	Snap Ring
13	3-07	Endplate
14	3-05	Eccentric Key
15	3-04	Eccentric Cam Assembly
16	2-04	Cycloid Discs
17	2-05	Disc Spacer
18	3-09	Spacer
19	1-06	Slow Speed Shaft Rollers
20	7	Housing Bolts
21	—	Washers
22	—	Nuts
23	—	Locknut
24	3-02	Bearing C
25	3-10	Snap Ring
26	—	Tap-End Stud
27	13	Fan Spacer
28	10	Fan Cover
29	7	Washers
30	7	Nuts
31	2-01	Ring Gear Housing
32	2-02	Ring Gear Pins
33	2-03	Ring Gear Rollers
34	6	Gasket*
35	6	Gasket*

\*Supplied as a set only



# Cyclo Parts List continued

## Cyclo Reducer Input Section

### Double Reduction

Figure 5.21

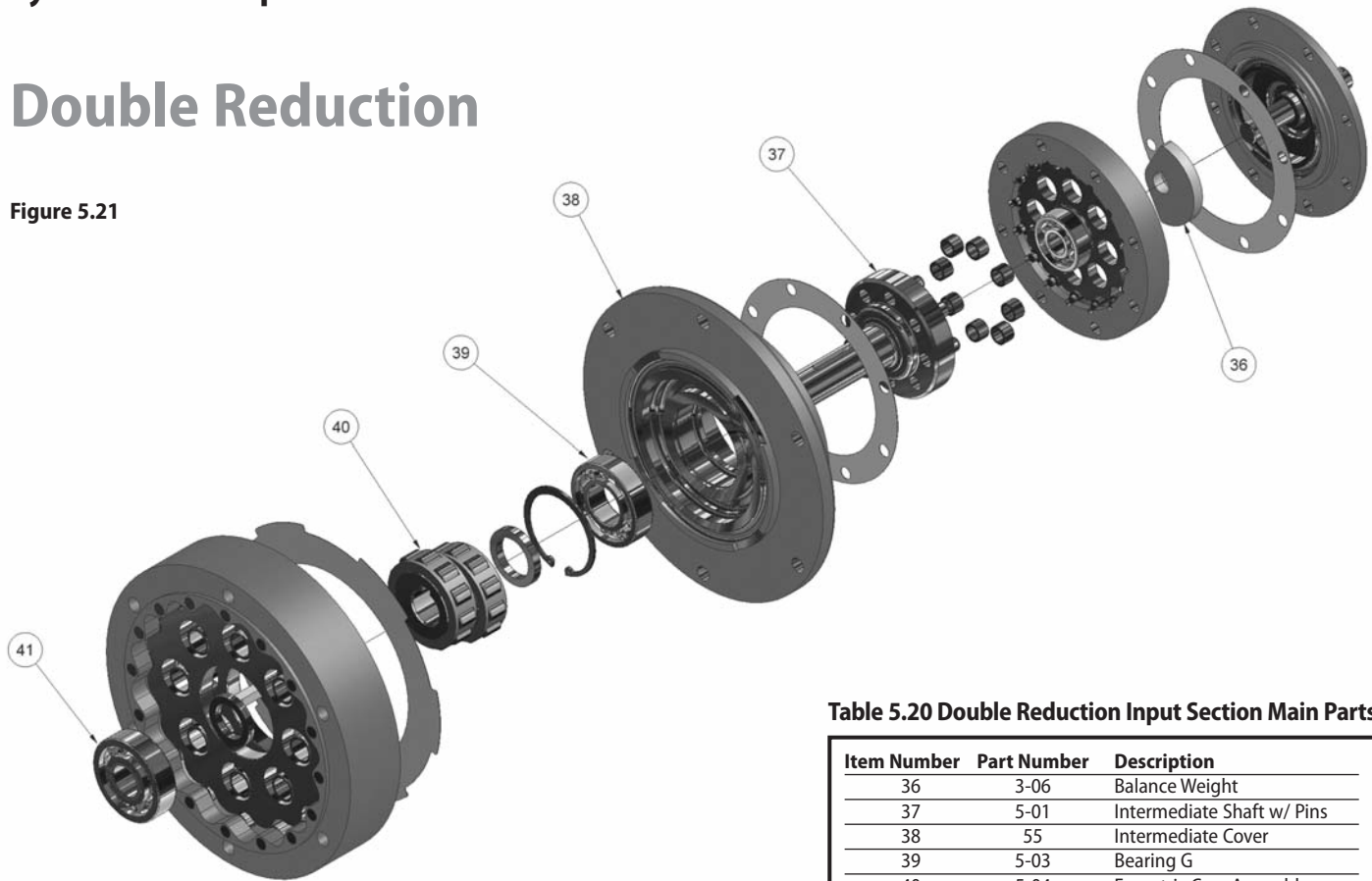


Table 5.20 Double Reduction Input Section Main Parts

Item Number	Part Number	Description
36	3-06	Balance Weight
37	5-01	Intermediate Shaft w/ Pins
38	55	Intermediate Cover
39	5-03	Bearing G
40	5-04	Eccentric Cam Assembly
41	5-02	Bearing F

**Note:** The parts listed are a general representation of the components found in a single and double reduction Cyclo.

Specific units may or may not contain all shown here.

Please consult the factory for specific part questions.

# Motor

## Motor Cover Mounting Specifications

Refer to dimension FA or FB when designing the mounting space into which the gearmotor is to fit.

**Dimension FA:** The space necessary to remove the fan cover or brake cover without removing the motor from the equipment.

**Dimension FB:** Minimum space required for adequate ventilation.

**Notes:**

1. It is necessary to remove the gearmotor from the equipment when removing the fan or brake cover.
2. AF (Inverter) motors of 40 HP (30kW) or greater are of a different ventilation type.

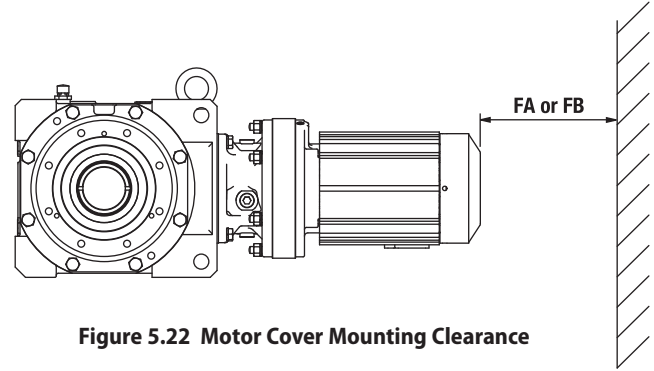


Figure 5.22 Motor Cover Mounting Clearance

Table 5.21 Space Requirements

Units: inches (mm)

Motor HP (kW) x Pole	Standard Motor				Brake Motor			
	3 Phase		Inverter Duty		3 Phase		Inverter Duty	
	FA	FB	FA	FB	FA	FB	FA	FB
1/8(0.1) x 4	-	-	1.9 (48)	0.8 (20)	2.0 (49)	-	2.5 (61)	0.8 (20)
1/4(0.2) x 4	1.9 (48)	0.8 (20)	1.9 (48)	0.8 (20)	2.5 (61)	0.8 (20)	2.5 (61)	0.8 (20)
1/3(0.25) x 4	1.9 (48)	0.8 (20)	1.9 (48)	0.8 (20)	2.5 (61)	0.8 (20)	2.5 (61)	0.8 (20)
1/2(0.4) x 4	1.9 (48)	0.8 (20)	2.0 (49)	0.8 (20)	2.5 (61)	0.8 (20)	3.7 (93)	0.8 (20)
3/4(0.55) x 4	2.0 (49)	0.8 (20)	2.1 (52)	0.8 (20)	3.7 (93)	0.8 (20)	4.6 (115)	0.8 (20)
1(0.75) x 4	2.0 (49)	0.8 (20)	2.1 (52)	0.8 (20)	3.7 (93)	0.8 (20)	4.6 (115)	0.8 (20)
1.5(1.1) x 4	2.1 (52)	0.8 (20)	2.2 (56)	0.8 (20)	4.6 (115)	0.8 (20)	5.2 (132)	0.8 (20)
2(1.5) x 4	2.1 (52)	0.8 (20)	2.2 (56)	0.8 (20)	4.6 (115)	0.8 (20)	5.2 (132)	0.8 (20)
3(2.2) x 4	2.2 (56)	0.8 (20)	2.4 (60)	0.8 (20)	5.2 (132)	0.8 (20)	5.2 (132)	0.8 (20)
5(3.7) x 4	2.4 (60)	0.8 (20)	2.4 (60)	0.8 (20)	5.2 (132)	0.8 (20)	5.2 (132)	0.8 (20)
7.5(5.5) x 4	2.4 (60)	0.8 (20)	3.0 (75)	1.0 (25)	5.2 (132)	0.8 (20)	6.7 (170)	1.0 (25)
10(7.5) x 4	3.0 (75)	1.0 (25)	3.0 (75)	1.0 (25)	6.7 (170)	1.0 (25)	6.7 (170)	1.0 (25)
15(11) x 4	3.0 (75)	1.0 (25)	5.2 (130)	1.2 (30)	6.7 (170)	1.0 (25)	8.7 (220)	1.2 (30)
20(15) x 4	5.2 (130)	1.2 (30)	6.2 (155)	1.2 (30)	8.7 (220)	1.2 (30)	14.5 (367)	1.2 (30)
25(18.5) x 4	6.2 (155)	1.2 (30)	6.7 (170)	1.2 (30)	14.5 (367)	1.2 (30)	14.6 (370)	1.2 (30)
30(22) x 4	6.2 (155)	1.2 (30)	6.7 (170)	1.2 (30)	14.5 (367)	1.2 (30)	14.6 (370)	1.2 (30)
40(30) x 4	6.7 (170)	1.2 (30)	5.6 (140)	1.2 (30)	14.6 (370)	1.2 (30)	11.7 (295)	1.2 (30)
50(37) x 4	9.1 (230)	1.2 (30)	5.6 (140)	1.2 (30)	17.6 (445)	1.2 (30)	11.7 (295)	1.2 (30)

Cyclo BBB

Appendix

Conduit Box Dimensions

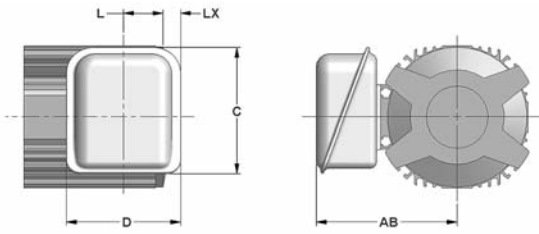


Figure 5.23 Non-UL Indoor Duty

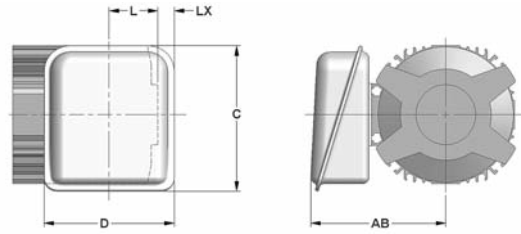


Figure 5.24 UL Indoor Duty

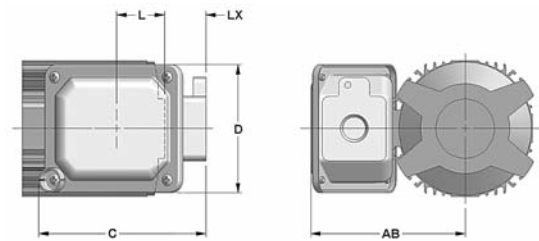


Figure 5.25 Non-UL & UL Washdown Duty

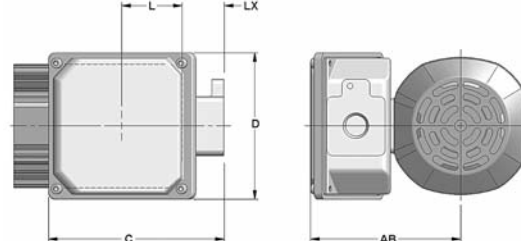


Figure 5.26 Global

Table 5.22 Terminal Box Mounting Centers

Units: inches

Frame Size	Duty Rating	Without Brake					With Brake					Conduit Opening
		AB	C	D	L	LX	AB	C	D	L	LX	
V-63S	Non-UL Indoor Duty	4.13	3.78	3.35		.30	5.20	5.67	4.80		–	0.90 dia
	UL Indoor Duty	5.20	5.67	4.80		1.02	5.20	5.67	4.80		–	0.90 dia
	Non-UL & UL Washdown Duty	5.00	5.16	3.94	1.38	1.58	5.00	5.16	3.94	2.76	0.20	PF 1/2
	Global	5.04	5.91	4.92		2.05	5.04	5.91	4.92		0.67	NPT 1/2
	Small Global	4.45	4.41	4.09		0.80	4.45	4.41	4.09		–	NPT 1/2
V-63M V-71M VA-63S VA-63M	Non-UL Indoor Duty	4.13	3.78	3.35		–	5.20	5.67	4.80		–	0.90 dia
	UL Indoor Duty	5.20	5.67	4.80		.06	5.20	5.67	4.80		–	0.90 dia
	Non-UL & UL Washdown Duty	5.00	5.16	3.94	2.34	0.62	5.00	5.16	3.94	3.58	–	PF 1/2
	Global	5.04	5.91	4.92		1.09	5.04	5.91	4.92		–	NPT 1/2
	Small Global	4.45	4.41	4.09		–	4.45	4.41	4.09		–	NPT 1/2
V-80S V-80M VA-71M	Non-UL Indoor Duty	4.69	3.78	3.35		–	5.79	5.67	4.80		–	0.90 dia
	UL Indoor Duty	5.79	5.67	4.80		–	5.79	5.67	4.80		–	0.90 dia
	Non-UL & UL Washdown Duty	5.55	5.16	3.94	3.82	–	5.55	5.16	3.94	5.53	–	PF 3/4
	Global	5.63	5.91	4.92		–	5.63	5.91	4.92		–	NPT 3/4
	Small Global	4.45	4.41	4.09		–	4.45	4.41	4.09		–	NPT 1/2
V-90S V-90L VA-80S VA-80M	Non-UL Indoor Duty	4.88	3.78	3.35		–	5.98	5.67	4.80		–	0.90 dia
	UL Indoor Duty	5.98	5.67	4.80		–	5.98	5.67	4.80		–	0.90 dia
	Non-UL & UL Washdown Duty	5.75	5.16	3.94	3.98	–	5.75	5.16	3.94	6.42	–	PF 3/4
	Global	5.83	5.91	4.92		–	5.83	5.91	4.92		–	NPT 3/4
	Small Global	4.45	4.41	4.09		–	4.45	4.41	4.09		–	NPT 1/2
V-100L VA-90S VA-90L	Non-UL Indoor Duty	5.16	3.78	3.35		–	6.26	5.67	4.80		–	0.90 dia
	UL Indoor Duty	6.26	5.67	4.80		–	6.26	5.67	4.80		–	0.90 dia
	Non-UL & UL Washdown Duty	6.02	5.16	3.94	4.17	–	6.02	5.16	3.94	6.65	–	PF 3/4
	Global	6.10	5.91	4.92		–	6.10	5.91	4.92		–	NPT 3/4
	Small Global	4.45	4.41	4.09		–	4.45	4.41	4.09		–	NPT 1/2
V-112M VA-100L	Non-UL Indoor Duty	5.80	4.41	3.94		–	6.69	5.67	4.80		–	0.90 dia
	UL Indoor Duty	6.69	5.67	4.80		–	6.69	5.67	4.80		–	0.90 dia*
	Non-UL & UL Washdown Duty	7.20	6.02	4.84	5.00	–	7.20	6.02	4.84	7.83	–	PF 3/4
	Global	6.54	5.91	4.92		–	6.54	5.91	4.92		–	NPT 3/4
	Small Global	4.45	4.41	4.09		–	4.45	4.41	4.09		–	NPT 1/2
V-132S VA-112M	Non-UL Indoor Duty	5.80	4.41	3.94		–	6.69	5.67	4.80		–	0.90 dia
	UL Indoor Duty	6.69	5.67	4.80		–	6.69	5.67	4.80		–	0.90 dia*
	Non-UL & UL Washdown Duty	7.20	6.02	4.84	5.00	–	7.20	6.02	4.84	7.83	–	PF 1
	Global	6.54	5.91	4.92		–	6.54	5.91	4.92		–	NPT 1
	Small Global	4.45	4.41	4.09		–	4.45	4.41	4.09		–	NPT 1/2
F-132M FA-132S	UL Indoor Duty	7.40	5.44	4.80		–	7.40	5.44	4.80		–	1.69 dia
	Non-UL & UL Washdown Duty	8.74	7.37	6.06	5.63	–	8.74	7.37	6.06	9.37	–	PF 1
	Global	8.31	7.83	6.69		–	8.31	7.83	6.69		–	NPT 1
F-160M FA132M	UL Indoor Duty	7.40	5.44	4.80		–	7.40	5.44	4.80		–	1.69 dia
	Non-UL & UL Washdown Duty	8.74	7.37	6.06	5.63	–	8.74	7.37	6.06	9.37	–	PF 1-1/4
	Global	8.31	7.83	6.69		–	8.31	7.83	6.69		–	NPT 1

\*1.38 dia. may be found for some of these sizes

# Motor continued

## Standard Motor Data

Table 5.23 Single Phase, 115/230V, 60Hz, 1800 RPM, Synchronous Speed, TEFC

HP	Frame Size	Full Load		Current (A)				Starting Breakdown		Power		Inertia WR <sup>2</sup> lb·in <sup>2</sup>
		Rated RPM	Torque in·lbs	Full Load 115V	Full Load 230V	No Load % of FL	Starting % of FL	Torque % of FL	Torque % of FL	Efficiency %	Factor %	
1/8	TS-71S	1730	4.52	3.56	1.88	91.3%	475%	468%	582%	42.2%	54.1%	5.13
1/4	TS-71S	1680	9.37	4.8	2.4	67.7%	352%	225%	280%	49.9%	69.6%	5.13
1/3	TS-71	1745	12.0	6.4	3.2	75.3%	525%	378%	368%	58.1%	58.2%	7.69
1/2	TS-71	1720	18.3	7.8	3.9	61.8%	431%	252%	245%	61.7%	68.8%	7.69
3/4	TS-90	1730	27.3	10.4	5.2	71.3%	590%	395%	465%	71.4%	68.1%	20.5
1	TS-90	1700	37.0	12.4	6.2	59.8%	495%	290%	340%	69.4%	77.1%	20.5

Table 5.24 Three Phase, 230/460V, 60Hz, 1800 RPM Synchronous Speed, TEFC

HP	Frame Size	Full Load		Current (A)				Starting Breakdown		Efficiency %	Power Factor %	NEMA Code Letter	Inertia WR <sup>2</sup> lb·in <sup>2</sup>
		Rated RPM	Torque in·lbs	Full Load 230V	Full Load 460V	No Load % of FL	Starting % of FL	Torque (% of FL)	Torque (% of FL)				
1/8**	V-63S	1730	4.55	0.66	0.33	86.1%	424%	326%	308%	63.3%	60.0%	K	1.11
1/4	V-63M	1730	9.10	1.12	0.56	79.6%	464%	300%	287%	69.2%	65.1%	K	1.71
1/3	V-63M	1700	12.2	1.24	0.62	72.0%	419%	237%	226%	70.1%	72.0%	G	1.71
1/2	V-71M	1750	18.0	2.15	1.08	77.7%	456%	295%	276%	71.5%	65.4%	J	2.22
3/4	V-80S	1720	27.5	2.47	1.24	68.4%	500%	266%	261%	76.5%	73.1%	H	3.45
1	V-80M	1740	36.2	3.38	1.69	69.8%	521%	278%	303%	76.9%	72.4%	H	4.10
1.5	V-90S	1720	54.9	4.66	2.33	64.4%	614%	273%	290%	79.8%	74.3%	J	6.32
2	V-90L	1740	72.4	6.07	3.04	61.6%	606%	263%	275%	81.9%	75.8%	J	7.28
3	V-100L	1730	109	8.5	4.25	57.2%	645%	277%	311%	83.9%	77.4%	J	11.4
5	V-112M	1730	182	13.1	6.55	47.8%	702%	278%	293%	85.8%	82.7%	J	29.0
7.5	V-132S	1710	276	18.2	9.08	32.4%	661%	223%	252%	86.2%	88.3%	H	39.0
10	F-132M	1750	360	23.7	11.9	27.8%	620%	212%	228%	88.9%	89.7%	G	91.6
15	F-160M	1750	540	34.1	17.1	27.6%	677%	248%	258%	90.1%	90.0%	G	128
20	G-160L	1750	720	45.7	22.9	22.3%	595%	222%	220%	90.8%	90.7%	F	307
25	F-180MG	1770	890	58.0	29.0	36.1%	917%	361%	328%	92.0%	86.9%	K	769
30	F-180MG	1760	1090	67.8	33.9	30.5%	785%	303%	275%	92.1%	88.5%	J	769
40	F-180L	1760	1430	93.3	46.7	31.4%	755%	310%	274%	92.2%	87.6%	H	854

Note: \*\* 1/8 HP is TENV.

Table 5.25 Three Phase, 230/460V, 60Hz, 1200 RPM Synchronous Speed, TEFC

HP	Frame Size	Full Load		Current (A)				Starting Breakdown		Efficiency %	Power Factor %	NEMA Code Letter	Inertia WR <sup>2</sup> lb·in <sup>2</sup>
		Rated RPM	Torque in·lbs	Full Load 230V	Full Load 460V	No Load % of FL	Starting % of FL	Torque % of FL	Torque % of FL				
20	F-180MG	1180	1070	48.4	24.2	39.5%	748%	273%	306%	92.3%	84.3%	J	1090
25	F-180L	1180	1330	58.5	29.3	35.4%	704%	261%	286%	91.7%	86.6%	J	1240
30	F-180L	1180	1600	71	35.6	39.1%	713%	273%	297%	92.0%	84.4%	H	1240
40	F-200L	1180	2130	95.4	47.7	36.3%	738%	318%	305%	92.6%	85.4%	H	1620

# Motor continued

## CSA Approved Motor Data

Table 5.26 Three Phase, 230/460V, 60Hz, 1800 RPM Synchronous Speed, TEFC

HP	Frame Size	Full Load		Current (A)				Starting Breakdown		Power		NEMA Code Letter	Inertia WR <sup>2</sup> lb·in <sup>2</sup>
		Rated RPM	Torque in-lbs	Full Load 230V	Full Load 460V	No Load % of FL	Starting % of FL	Torque % of FL	Torque % of FL	Efficiency %	Factor %		
1/8**	V-63S	1720	4.58	0.71	0.35	91.4%	457%	378%	393%	65.5%	54.1%	M	1.11
1/4	V-63M	1730	9.10	1.20	0.60	86.0%	450%	309%	343%	69.4%	60.1%	K	1.71
1/3	V-63M	1710	12.2	1.30	0.65	79.4%	415%	244%	272%	71.3%	67.5%	H	1.71
1/2	V-71M	1700	18.5	2.10	1.10	81.0%	481%	343%	331%	75.2%	63.1%	K	2.22
3/4	V-80S	1700	27.8	2.60	1.30	70.8%	515%	263%	272%	75.4%	71.4%	H	3.45
1	V-80M	1700	37.0	3.60	1.80	75.6%	572%	341%	315%	78.0%	66.9%	K	4.10

Note: \*\* 1/8 HP is TENV.



Dimensions for units with CSA approved motors may be different than those specified in Section 4. Please consult factory for details.

## EPACT/EEV Efficiency Motors

Table 5.27 Three Phase, 230/460V, 60Hz, 1800 RPM Synchronous Speed, TEFC

HP	Frame Size	Full Load		Current (A)				Starting Breakdown		Power		NEMA Code Letter	Inertia WR <sup>2</sup> lb·in <sup>2</sup>
		Rated RPM	Torque in-lbs	Full Load 230V	Full Load 460V	No Load % of FL	Starting % of FL	Torque % of FL	Torque % of FL	Efficiency %	Factor %		
1	VA-80M	1740	36.2	3.2	1.6	70.0%	700%	320%	379%	84.5%	68.2%	K	7.28
1.5	VA-90S	1740	54.3	4.6	2.3	64.6%	678%	319%	364%	85.7%	71.1%	K	11.4
2	VA-90L	1730	72.8	5.8	2.9	60.3%	717%	271%	306%	86.6%	74.9%	K	11.4
3	VA-100L	1750	108	8.1	4.1	56.9%	879%	310%	406%	89.1%	76.4%	L	29.0
5	VA-112M	1740	181	12.7	6.4	45.1%	781%	302%	330%	89.5%	81.6%	J	39.0
7.5	FA-132S	1750	270	18.5	9.2	46.6%	801%	309%	345%	90.7%	82.5%	J	91.6
10	FA-132M	1750	360	24.5	12.2	38.9%	828%	284%	303%	90.4%	85.1%	K	128
15	G-160L	1770	534	35.9	18.0	41.8%	928%	335%	335%	92.9%	82.7%	K	307
20	G-160L	1770	712	48.7	24.3	41.6%	984%	351%	354%	92.8%	83.5%	L	307
25	F-180L	1780	885	61.0	30.4	40.1%	803%	336%	305%	92.4%	82.7%	J	854
30	F-180L	1780	1060	71.0	35.4	34.5%	689%	282%	256%	92.4%	84.5%	H	854
40	F-200L	1780	1420	98.0	49.1	38.3%	740%	288%	279%	93.4%	82.1%	J	1050

CycloBBB

Appendix

# Motor continued

## CSA Approved Motor Data continued

Table 5.28 Three Phase, 575V, 60Hz, 1800 RPM Synchronous Speed, TEFC

HP	Frame Size	Full Load		Current (A)			Starting Breakdown		Efficiency %	Power Factor %	NEMA Code Letter	Inertia WR <sup>2</sup> lb·in <sup>2</sup>
		Rated RPM	Torque in-lbs	Full Load	No Load % of FL	Starting % of FL	Torque % of FL	Torque % of FL				
1/8**	V-63S	1720	4.58	0.28	91.8%	464%	376%	391%	65.3%	54.1%	M	1.11
1/4	V-63M	1730	9.10	0.48	85.4%	458%	316%	340%	69.4%	60.3%	K	1.71
1/3	V-63M	1710	12.2	0.52	78.8%	423%	250%	270%	71.3%	67.4%	H	1.71
1/2	V-71M	1700	18.5	0.79	75.8%	468%	309%	300%	75.8%	67.4%	J	2.22
3/4	V-80S	1700	27.8	1.00	74.0%	530%	260%	268%	75.1%	71.6%	H	3.45
1	V-80M	1700	37.0	1.30	65.4%	508%	252%	256%	78.1%	74.9%	H	4.10

Note: \*\* 1/8 HP is TENV.



Dimensions for units with CSA approved motors may be different than those specified in Section 4. Please consult factory for details.

## EPACT/EEV Efficiency Motors

Table 5.29 Three Phase, 575V, 60Hz, 1800 RPM Synchronous Speed, TEFC

HP	Frame Size	Full Load		Current (A)			Starting Breakdown		Efficiency %	Power Factor %	NEMA Code Letter	Inertia WR <sup>2</sup> lb·in <sup>2</sup>
		Rated RPM	Torque in-lbs	Full Load	No Load % of FL	Starting % of FL	Torque % of FL	Torque % of FL				
1	VA-80M	1740	36.2	1.3	66.5%	685%	320%	379%	84.8%	68.2%	K	7.28
1.5	VA-90S	1740	54.3	1.8	62.2%	689%	319%	364%	85.7%	71.1%	K	11.4
2	VA-90L	1730	72.8	2.4	56.7%	692%	326%	371%	86.1%	73.6%	K	11.4
3	VA-100L	1750	108	3.3	53.9%	833%	354%	417%	87.9%	78.5%	L	29.0
5	VA-112M	1740	181	5.2	45.6%	769%	295%	346%	88.7%	81.7%	J	39.0
7.5	FA-132S	1750	270	7.5	45.2%	709%	288%	331%	89.9%	83.6%	H	91.6
10	FA-132M	1760	358	9.7	39.5%	849%	314%	340%	91.5%	84.5%	K	128
15	G-160L	1770	534	14.7	41.5%	925%	338%	338%	92.8%	82.7%	L	307
20	G-160L	1770	712	19.2	38.5%	927%	327%	330%	93.0%	84.5%	K	307
25	F-180L	1780	885	24.5	38.8%	776%	330%	285%	92.7%	82.9%	J	854
30	F-180L	1780	1060	28.9	32.9%	657%	275%	237%	92.5%	84.5%	H	854
40	F-200L	1780	1420	38.8	37.9%	714%	283%	274%	93.5%	83.0%	H	1050

Cyclo BBB

Appendix

### Standard Wiring Diagrams

Illustrated below are the wiring diagrams for our standard motors, for additional information please refer to the motor name plate. Due to changes in design features, this diagram may not always agree with that on the motor. If different, the motor diagram found inside the conduit box cover is correct.

### 3-Phase Motors (230/460 V)

Figure 5.27 WYE-Connected (5 HP and smaller)

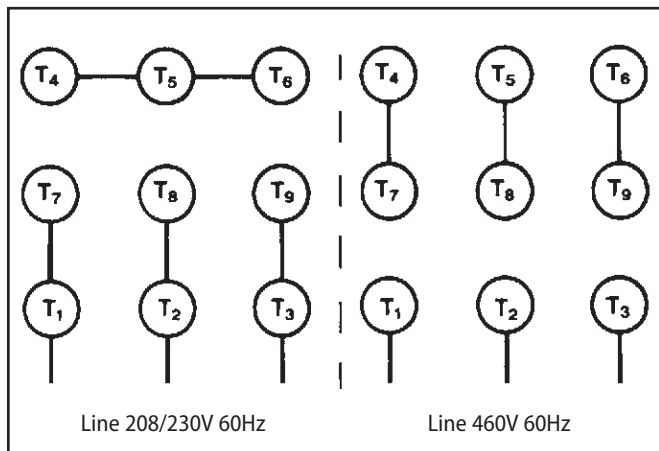
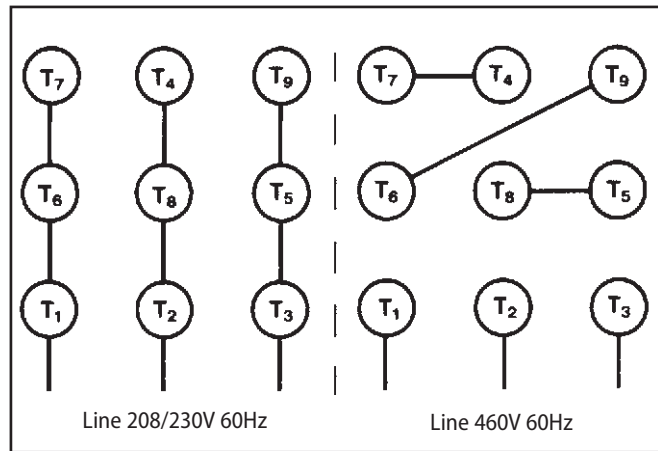
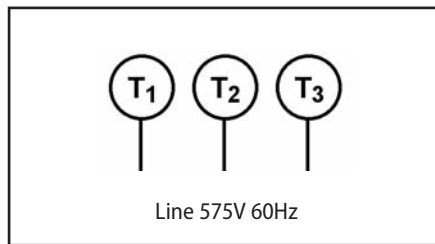


Figure 5.28 DELTA-Connected (7.5 HP and larger)



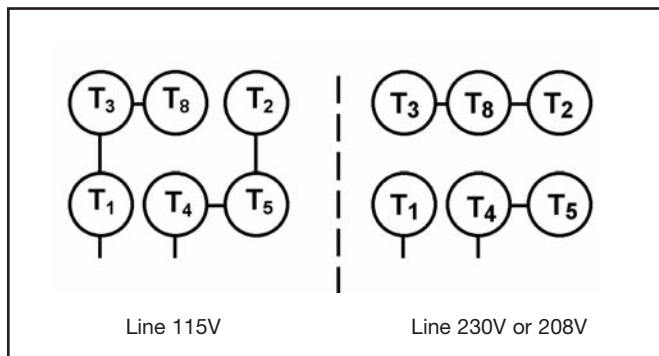
### Three Phase Motors (575V)

Figure 5.29 Three Phase, 575V



### Single Phase Motors

Figure 5.30 Single Phase, 115V, 230V, 208V



CycloBBB

Appendix

# Motor continued

## Motor Thermal Rating (C x Z)

Table 5.30 Motor Thermal Rating (C x Z)

Motor Power HP	Allowable C x Z				Motor Moment of Inertia lb-in <sup>2</sup>	
	35% ED <sup>[1]</sup>	35%~50% ED <sup>[1]</sup>	50~80% ED <sup>[1]</sup>	80~100% ED <sup>[1]</sup>	Standard	with Brake
1/8	3200	3000	2000	1200	1.11	1.20
1/4	2200	2800	2800	2500	1.71	1.88
1/3	2200	2800	2800	2500	1.71	1.88
1/2	1800	2200	1500	1500	2.22	2.31
3/4	1800	2200	1500	1500	3.45	3.79
1	1400	1400	800	500	4.10	4.44
1.5	1400	1400	800	500	6.32	7.11
2	1200	1200	500	400	7.28	8.03
3	1000	900	400	200	11.4	12.8
5	800	800	800	700	29.0	32.7
7.5	300	300	200	150	39.0	42.7
10	400	350	300	300	91.6	104
15	200	200	150	150	128	140

Note: [1] % ED = duty cycle.

The calculated C x Z value (steps 1 – 3 outlined below) should be less than the allowable value listed in Motor Thermal Rating table above.

### 1. Obtain the C value:

$$C = \frac{I_M + I_L}{I_M}$$

$I_M$  = Moment of Inertia of Motor.

$I_L$  = Total Moment of Inertia of Load as seen from the motor.

### 2. Obtain the Z value (number of starts per hour):

(a) Assume that one operating period consists of "on-time"  $t_a$  (sec.), "off-time"  $t_b$  (sec.) and the motor is started  $nr$  (times/sec.).

$$Z_r = \frac{3600nr}{t_a + t_b} \text{ (times/hour)}$$

(b) When inching,  $ni$  (times/cycle) is included in 1 cycle ( $t_a + t_b$ ), the number of inching times per hour  $Z_i$ , is then included in the number of starts.

$$Z_i = \frac{3600ni}{t_a + t_b} \text{ (times/hour)}$$

(c) Calculate Z by adding  $Z_r$  to  $Z_i$ .

$$Z = Z_r + \frac{1}{2} Z_i = \frac{3600}{t_a + t_b} \cdot \left( nr + \frac{1}{2} ni \right) \text{ (times/hour)}$$

### 3. Calculate C multiplied by Z:

Use the value of C obtained in step (1) and Z from step (2)

### 4. Obtain the duty cycle %ED and check with Motor Thermal Rating table above.

$$\%ED = \frac{t_a}{t_a + t_b} \times 100 \quad \begin{array}{l} t_a = \text{on-time} \\ t_b = \text{off-time} \end{array}$$



## Brakemotor Characteristics

The brakemotor on Cyclo® BBB gearmotors operates with direct current supplied by a dual voltage rectifier for 230/460V, or single voltage rectifier/power module for other noted voltages. Rectifier or power module is mounted in the motor conduit box.

When used for outdoor installations, our standard brakemotor must be protected with some type of covering. Such type of coverings are available from the factory, please inquire when ordering.

**Note:** Advise the factory when ordering if you require larger or smaller brake torque than those shown as standard in the Brakemotor Characteristics table below.

## Brake Characteristics

Table 5.31 Standard Brake Models

Brake Model	Motor Capacity <sup>[1]</sup> (HP x 4P)		Braking Torque (ft-lbs)			Braking Delay Time (sec)			Standard Brake Current (AC Amps)				
	Standard	AF-Motor	Min.	Std.	Max.	Normal Braking Action		Fast Braking Action	230VAC	460VAC	575VAC	200VAC	220VAC
						Standard Wiring	Inverter Wiring <sup>[2]</sup>						
FB-01A	1/8	–	0.24	0.7	0.96	0.15 ~ 0.2	–	0.015 ~ 0.02	0.06	0.04	0.03		
FB-02A	1/4, 1/3	1/8	0.48	1.4	1.9		0.8 ~ 0.12						
FB-05A	1/2	1/4, 1/3	0.96	2.9	2.9	0.1 ~ 0.15	0.03 ~ 0.07	0.01 ~ 0.015	0.1	0.06	0.07		
FB-1D	3/4, 1	1/2	1.9	5.8	7.7								
FB-2D	1.5, 2	3/4, 1	3.6	11	14	0.2 ~ 0.3	0.1 ~ 0.15	0.01 ~ 0.02	0.2	0.2	0.2	–	–
FB-3D	3	1.5, 2	5.3	16	21								
FB-5B	5	3	9	27	36	0.4 ~ 0.5	0.2 ~ 0.25	0.03 ~ 0.04	0.3	0.3	0.4		
FB-8B	7.5	5	13	40	55	0.3 ~ 0.4	0.1 ~ 0.15						
FB-10B	10	7.5	18	54	72	0.7 ~ 0.8	0.25 ~ 0.3	0.03 ~ 0.04	0.5	0.5	0.4		
FB-15B	15	10	27	80	108	0.5 ~ 0.6	0.15 ~ 0.2						
CMB-20	20	15	58	72	72	0.6 ~ 0.8 (other) 0.4 ~ 0.5 (460V)	0.3 ~ 0.35 (other) 0.1 ~ 0.15 (460V)	0.1 ~ 0.15	1.6	1.8	1.4		
FB-20 <sup>[3]</sup>	20	15	40	110	160	1.7 ~ 1.8	0.65 ~ 0.75	0.03 ~ 0.06					
FB-30 <sup>[3]</sup>	25	20	40	140	160	1.4 ~ 1.5	0.45 ~ 0.55	0.03 ~ 0.06	–	–	–	1.4/0.7 <sup>[4]</sup>	1.6/0.8 <sup>[4]</sup>
	30	–	40	160	160								
	40	30	40	160	160								

**Notes:** [1] May not apply to CSA Approved motors. Identify applicable brake model to motor frame size in Combination table below.

[2] Also applies to wiring where brake is powered separately from the motor leads.

[3] Available only with power module rated for use at 200VAC or 220VAC.

[4] 2 brake current values shown. First excitation current on initial power up. Second is holding current.

Table 5.32 Combination Table with Brakemotor Inertia

Brake Model	Motor Frame Sizes	Inertia WR <sup>2</sup> lb-in <sup>2</sup>
FB-01A	V-63S	1.20
FB-02A	V-63M, VA-63S	1.88
FB-05A	V-71M, VA-63M	2.31
FB-1D	V-80S	3.79
	V-80M, VA-71M	4.44
FB-2D	V-90S, VA-80S	7.11
	V-90L, VA-80M	8.03
FB-3D	VA-90S	10.4
	V-100L, VA-90L	12.7
FB-5B	V-112M, VA-100L	32.7
FB-8B	V-132S, VA-112M	42.7
FB-10B	F-132M, FA-132S	104
FB-15B	F-160M, FA-132M	140
CMB-20	G-160L	454
FB-20	G-160L	366
FB-30	F-180MG	830
	F-180L	895

# Motor Brakemotor, Standard Wiring

## Standard Wiring Connection, Dual Voltage

### Models FB-01A through FB-15B

Figure 5.31 Normal Brake Action, 230V, 575V

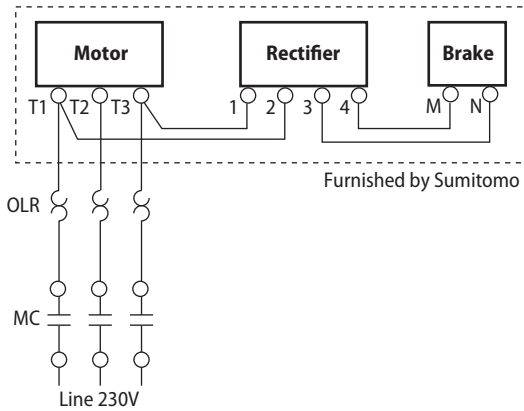


Figure 5.32 Fast Brake Action, 230V

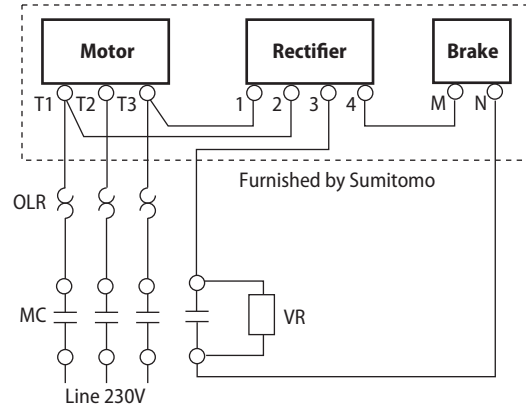


Figure 5.33 Normal Brake Action, 460V

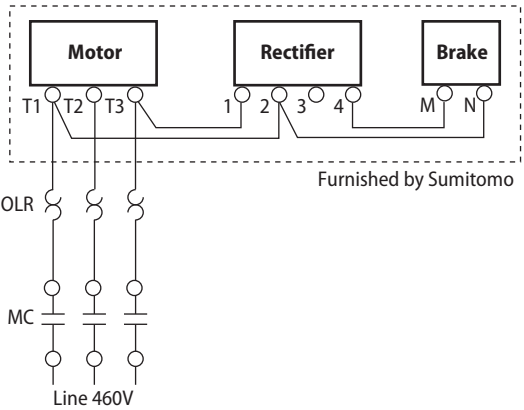
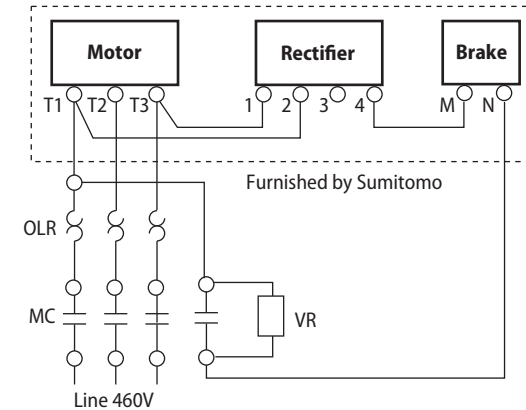


Figure 5.34 Fast Brake Action, 460V, 575V



- MC: Electromagnetic Relay
- MCB: Magnetic Circuit Breaker
- OLR: Overload or Thermal Relay
- VR: Varistor (protective device)<sup>(1)</sup>

Note: [1] Refer to Varistor Specifications Table

Table 5.33 Varistor Specifications Table

Operating Voltage		190-230V	380-460V	575V
Varistor Rated Voltage		AC260-300V	AC510V	AC604V
Varistor Voltage		430-470V	820V	1000V
Rated Watt	FB01A, 02A	Over 0.4W	Over 0.4W	Over 0.4W
	FB-05A	Over 0.4W	Over 0.4W	Over 0.4W
	FB-1D	Over 0.6W	Over 0.6W	Over 0.4W
	FB-2D, 3D	Over 1.5W	Over 1.5W	Over 0.6W
	FB-5B, 8B	Over 1.5W	Over 1.5W	Over 1.5W
	FB10B, 15B	Over 1.5W	Over 1.5W	Over 1.5W

# Motor Brakemotor Standard Wiring continued

## Models CMB-20

Figure 5.35 Normal Brake Action, 230V

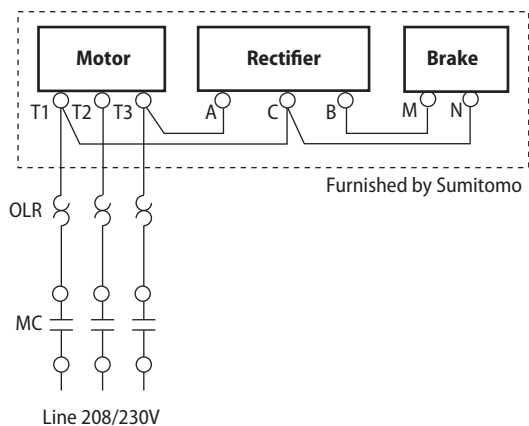


Figure 5.36 Fast Brake Action, 230V

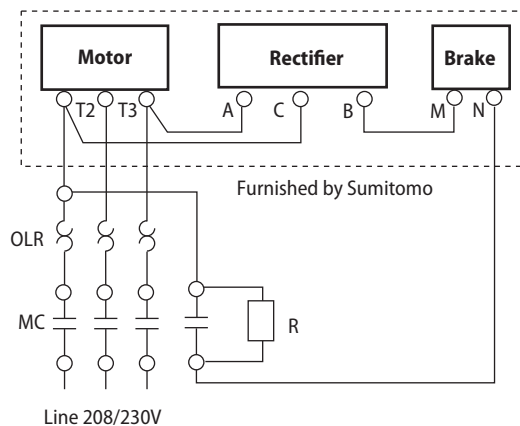


Figure 5.37 Normal Brake Action, 460V

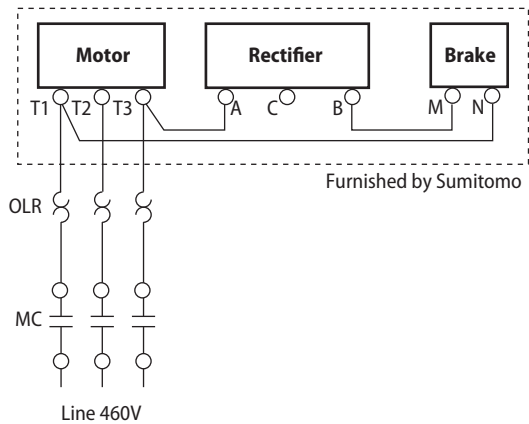


Figure 5.38 Fast Brake Action, 460V

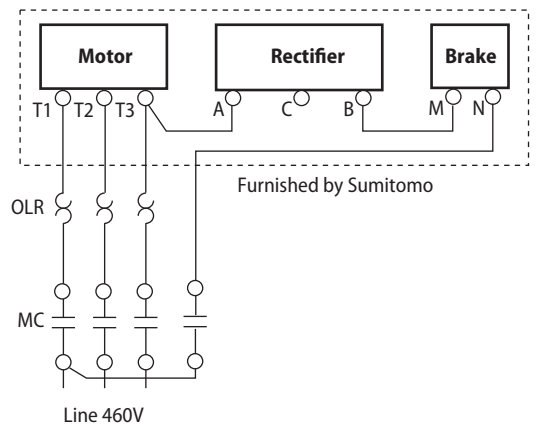


Figure 5.39 Normal Brake Action, 575V

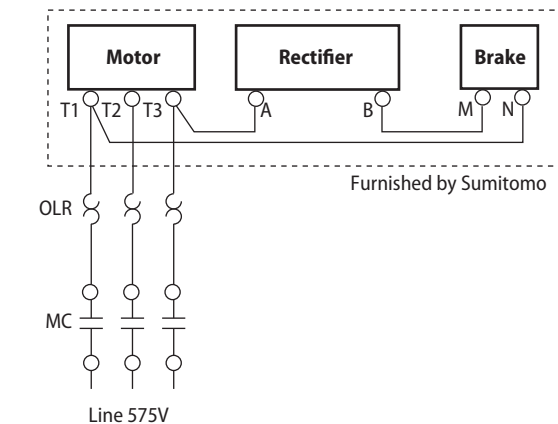
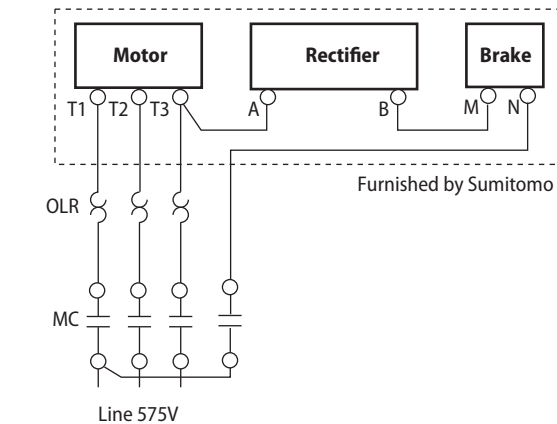


Figure 5.40 Fast Brake Action, 575V



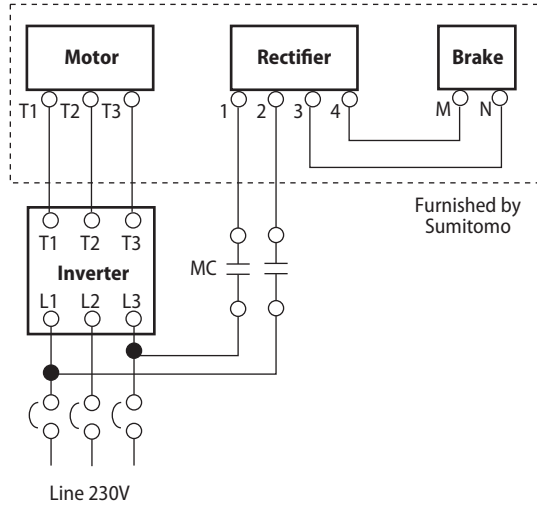
Cyclo BBB

Appendix

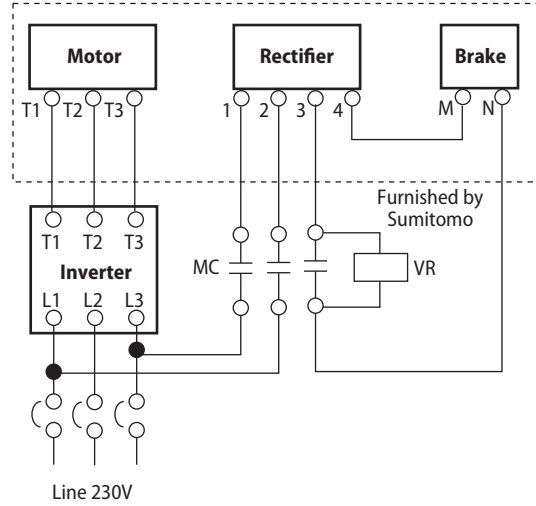
# Motor Brakemotor, Standard Wiring continued

## FB Brake (1/8 to 15 HP) with Inverter

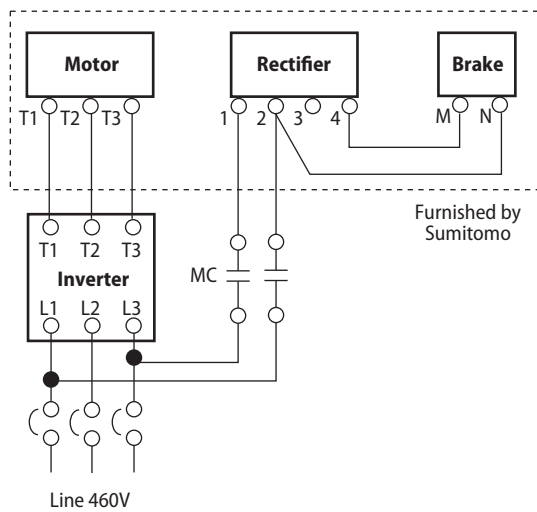
**Figure 5.41 Normal Brake Action, 230V, 575V**



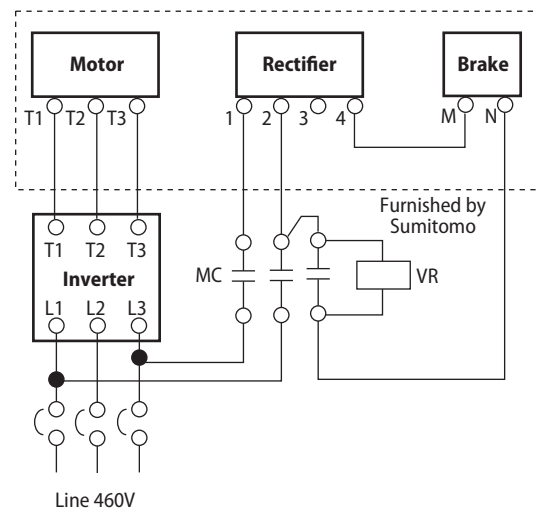
**Figure 5.42 Fast Brake Action, 230V, 575V**



**Figure 5.43 Normal Brake Action, 460V**



**Figure 5.44 Fast Brake Action, 460V**



- MC: Electromagnetic Relay
- MCB: Magnetic Circuit Breaker
- VR: Varistor (protective device)<sup>[1]</sup>

**Note:** [1] Refer to Varistor Specifications Table on pg. 5.22

Cyclo BBB

Appendix

## Brake Rectifiers and Power Modules

Table 5.34 Standard Brake Rectifiers

Brake Type	Motor (HP X P)	230V/460V Rectifier		575V Rectifier	
		Model Number	Part Number	Model Number	Part Number
FB-01A	1/8 x 4	25FW - 4FB3	EW107WW-01	10F-6FB3	EW104WW-01
FB-02A	1/4 x 4 1/3 x 4				
FB-05A	1/2 x 4				
FB-1D	3/4 x 4 1 x 4				
FB-2D	1.5 x 4 1 x 4				
FB-3D	3 x 4				
FB-5B	5 x 4				
FB-8B	7.5 x 4				
FB-10B	10 x 4				
FB-15B	15 x 4				
CMB-20	20 x 4	SB25F-3HS	DN937WW-G01	SB25-6H	DN934WW-G01

Table 5.35 Brake Power Modules

Brake Type	Motor (HP X P)	170 ~ 300VAC Module		380 ~ 480VAC Module	
		Model Number	Part Number	Model Number	Part Number
FB-20	20 x 4	13SR-2	ES075WW-01	10SR-4	MQ0003WW-01
FB-30	25 x 4 30 x 4 40 x 4				

# Lubrication

## Oil lubricated models are not filled with oil prior to shipping.

Before operating, fill the unit with the appropriate amount of the correct lubricant for the mounting position (see Table 5.37 and Figure 5.45). When operating in winter or other relatively low ambient temperatures, use the lower viscosity oil specified for each ambient temperature range. Please consult the factory if the unit will be operated consistently in ambient temperatures other than 32°F–104°F.

## Grease lubricated models are lubricated with grease prior to shipment from the factory.

Adding grease prior to initial start-up is not required. If grease must be replenished or changed (see Grease Lubrication section), avoid using greases other than those shown in the Table 5.38. Please consult the factory when the units will be used in widely fluctuating temperatures, ambient temperatures other than those specified in Table 5.38, or when other special conditions exist for the application. When motors from another manufacturer will be used, please consult and adhere to the associated motor maintenance manual for the appropriate lubrication instructions.

**Table 5.36 Lubrication Type Per Unit Size**

Unit Size	Output (Gear Side)	Input (Cyclo Side)	
		Motor Horizontal	Motor Vertical
3A100, 3A105, 3A110, 3A115 3A120, 3A125, 3B120, 3B125	Oil Bath	Grease	Grease
3A140, 3A145 3B140, 3B145, 3C140, 3C145, 3B160, 3B165, 3C160, 3C165, 3D160, 3D165, 3C170, 3C175, 3D170, 3D175 3E170, 3E175		Oil Bath	Grease

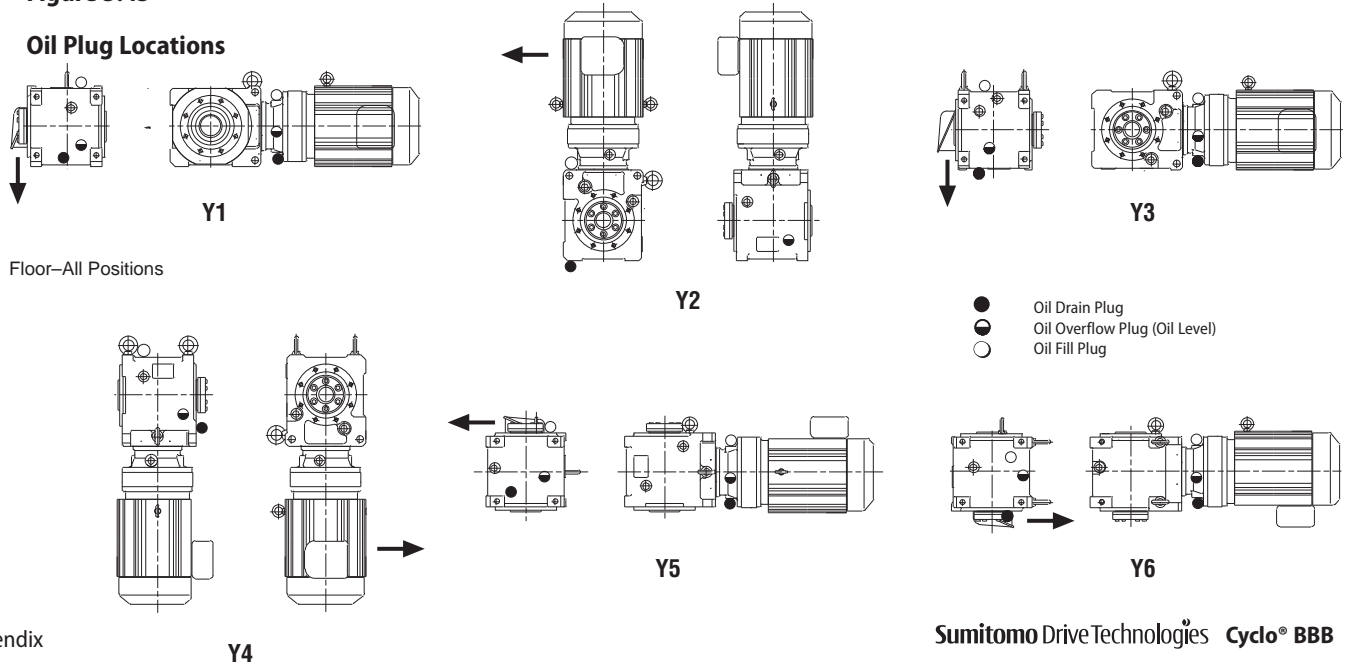
**Table 5.37 Standard Oils**

Ambient Temperature (°F)	ChevronTexaco	Exxon Oil	Mobil Oil	Shell Oil	BP Oil
14 to 41°	EP Gear Compound 68	Spartan EP 68	Mobilgear 600 XP 68 (ISO VG 68)	Omala S2 G Oil 68	Energol GR-XP 68
32 to 95°	EP Gear Compound 100, 150	Spartan EP 100 EP 150	Mobilgear 600 XP 100, 150 (ISO VG 100, 150)	Omala S2 G Oil 100, 150	Energol GR-XP 100 GR-XP 150
86 to 122°	EP Gear Compound 220, 320, 460	Spartan EP 220 EP 320 EP 460	Mobilgear 600 XP 200 320, 460 (ISO VG 220–460)	Omala S2 G Oil 220, 320 460	Energol GR-XP 220 GR-XP 320 GR-XP 460

**Table 5.38 Standard Greases**

Ambient Temperature (°F)	Reduction Ratio	Input (Cyclo Side)
14 to 122°	11, 18:1	Shell Alvania EP 00 Gadus S2 V220
	21:1 and higher	Exxon Unirex N2

**Figure 5.45 Oil Plug Locations**



# Lubrication continued

Table 5.39 Oil Fill Quantities Unit: U.S. Gallons

\*G = Grease

Frame Size	Mounting Configuration											
	Y1		Y2		Y3		Y4		Y5		Y6	
	Output	Input*	Output	Input*	Output	Input*	Output	Input*	Output	Input*	Output	Input*
3A100, 3A105		G		G		G		G		G		G
3A110, 3A115	0.29	G	0.26	G	0.29	G	0.26	G	0.45	G	0.42	G
3A120, 3A125		G		G		G		G		G		G
3A140, 3A145		0.08		G		0.08		G		0.08		0.08
3B120, 3B125		G		G		G		G		G		G
3B140, 3B145	0.48	0.12	0.37	G	0.48	0.12	0.48	G	0.61	0.12	0.66	0.12
3B160, 3B165		0.20		G		0.20		G		0.20		0.20
3C140, 3C145		0.12		G		0.12		G		0.12		0.12
3C160, 3C165	0.87	0.20	0.92	G	0.87	0.20	1.16	G	0.95	0.20	1.4	0.20
3C170, 3C175		0.28		G		0.28		G		0.28		0.28
3D160, 3D165		0.18		G		0.18		G		0.18		0.18
3D170, 3D175	1.16	0.24	1.32	G	1.16	0.24	1.11	G	1.48	0.24	1.59	0.24
3E170, 3E175	1.95	0.24	1.93	G	1.95	0.24	1.59	G	1.90	0.24	2.80	0.24

**Oil lubricated units** are shipped without oil. Prior to initial start-up, the unit must be filled with the correct amount of oil (see Table 5.39). For those units where both the gear and Cyclo portions are oil lubricated, the oil must be filled in two separate locations, one on the gear housing and one on the Cyclo housing.

**Grease lubricated models** are lubricated at the factory. Additional grease does not need to be added prior to initial start-up.

## Oil Replenishment and Change Interval

- Maintain proper oil levels at all times.
- An oil change after the first 500 hours of operation is highly recommended.
- Sumitomo recommends an oil change every 2500 hours, or six months, whichever comes first. If a proper preventive maintenance program is implemented and maintained, a longer change period may be acceptable.
- If the unit is running in a high ambient, high humidity, or corrosive environment, the lubricant will have to be changed more frequently. Consult the factory for recommendations.
- Note: The Cyclo portion and Bevel portion, where applicable, must be filled with oil separately. Oil does not flow from one section to the other.

## Grease Replenishment and Change Interval

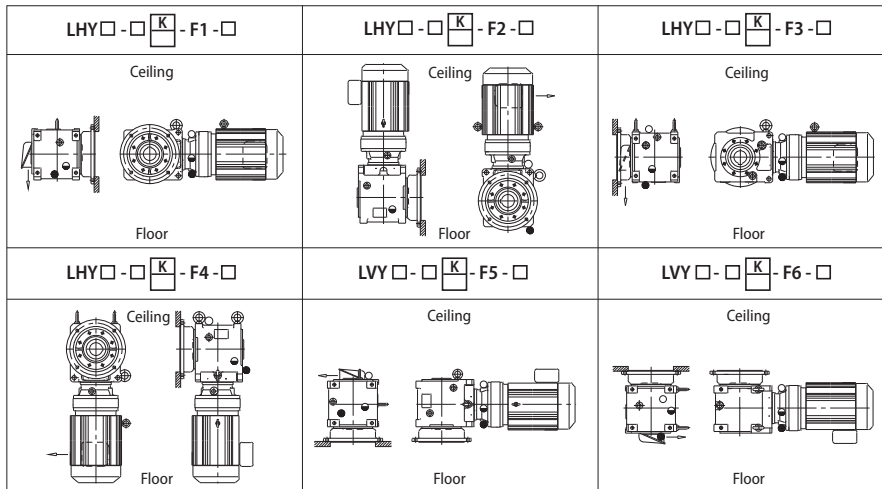
- On single reduction Cyclo Bevel Buddybox (Cyclo BBB) sizes 3A100~125 and 3B120~125, the Cyclo portion is grease lubricated as standard and therefore maintenance free. Consult the operations and maintenance manual for the grease change interval.
- When mounting Cyclo BBB sizes 3A140~145, 3B140~145, 3B160~165, and all sizes of 3C, 3D, and 3E in the Y2 and Y4 positions, please consult the maintenance and operations manual for the proper grease replenishment and change interval for the Cyclo portion.

Cyclo BBB

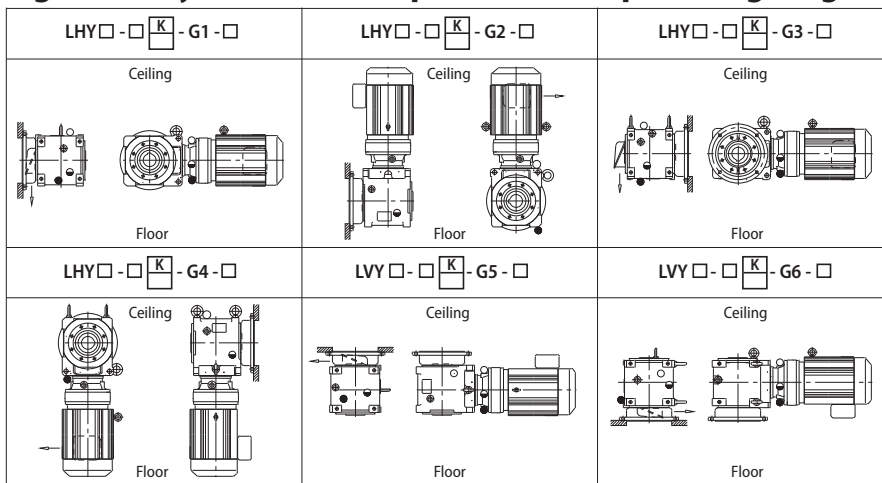
Appendix

# Additional Mounting Configurations

**Fig. 5.46 Keyed Hollow Output Bore – Output Flange Left**

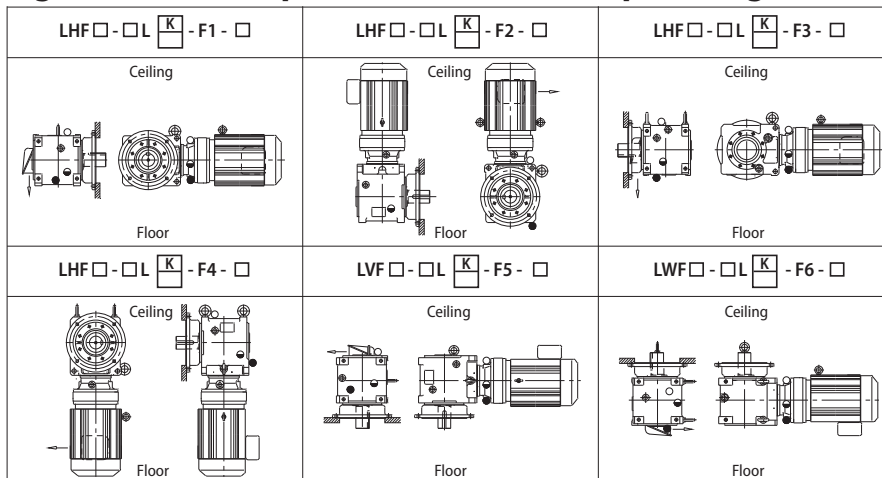


**Fig. 5.47 Keyed Hollow Output Bore - Output Flange Right**



Cyclo BBB

**Fig. 5.48 Solid Output Shaft Left (L) – Output Flange Left**

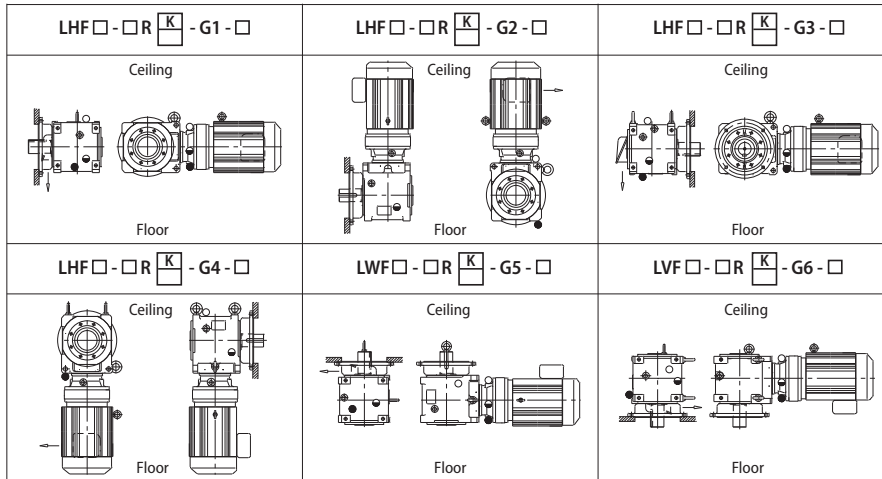


**Notes:** [1] **K** = inch diameter shaft or keyed hollow bore; **blank** = metric diameter shaft or keyed hollow bore.  
 [2] ○ = Oil Fill Location; ● = Oil Level Location; ● = Oil Drain Location.  
 [3] ← = direction of lead wires out of terminal box.

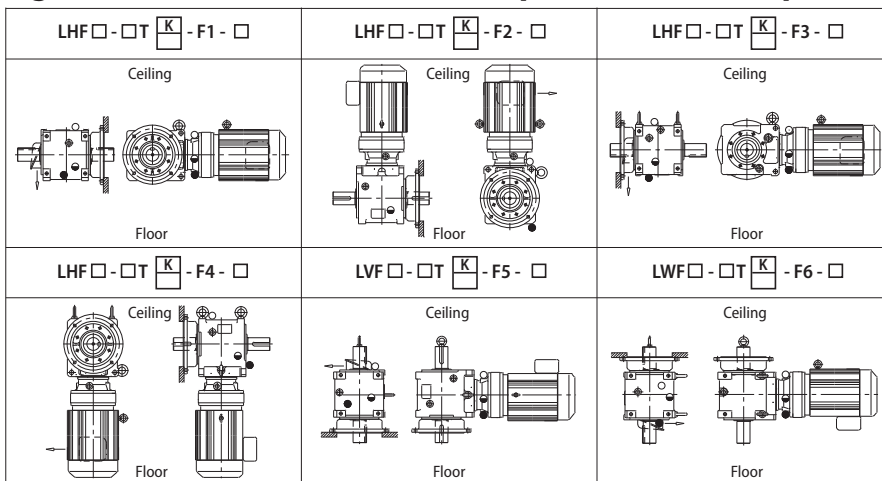


# Additional Mounting Configurations continued

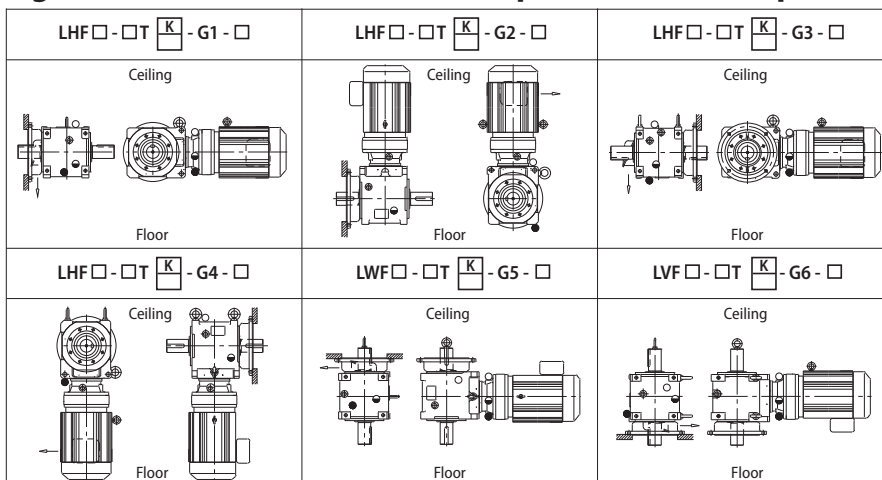
**Fig. 5.49 Solid Output Shaft Right (R) – Output Flange Right**



**Fig. 5.50 Double Extended Solid Output Shaft (T) – Output Flange Left**



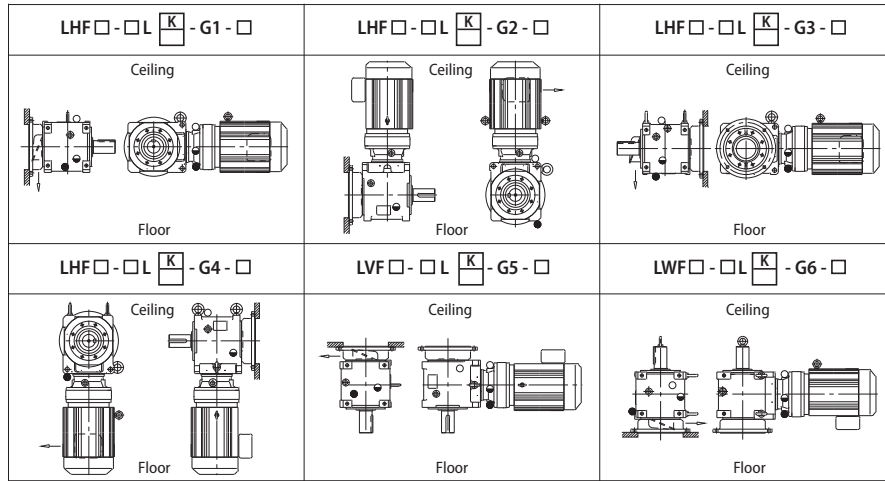
**Fig. 5.51 Double Extended Solid Output Shaft (T) – Output Flange Right**



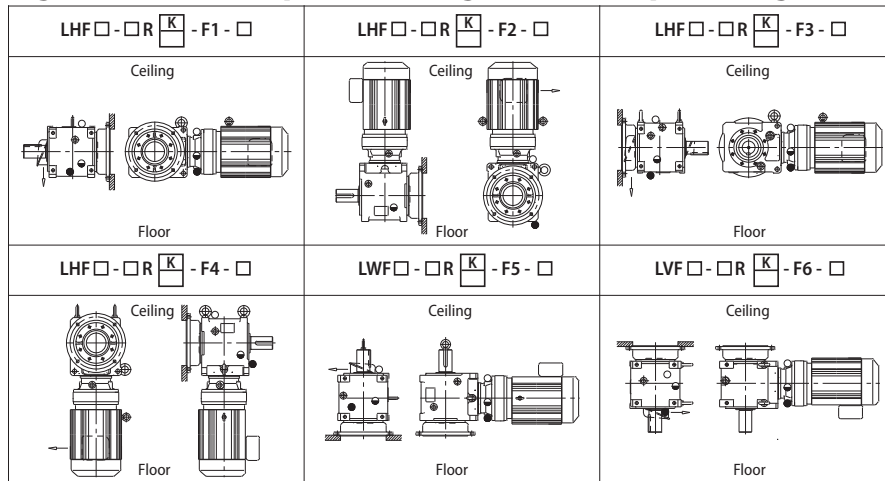
**Notes:** [1] K = inch diameter shaft or keyed hollow bore; **blank** = metric diameter shaft or keyed hollow bore.  
 [2] ○ = Oil Fill Location; ● = Oil Level Location; ● = Oil Drain Location.  
 [3] ← = direction of lead wires out of terminal box.

# Additional Mounting Configurations continued

**Fig. 5.52 Solid Output Shaft Left (L) – Output Flange Right**

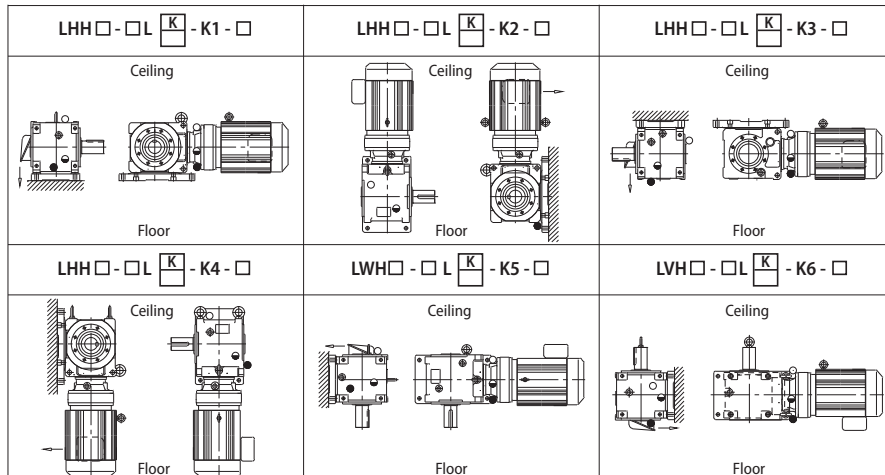


**Fig. 5.53 Solid Output Shaft Right (R) – Output Flange Left**



Cyclo BBB

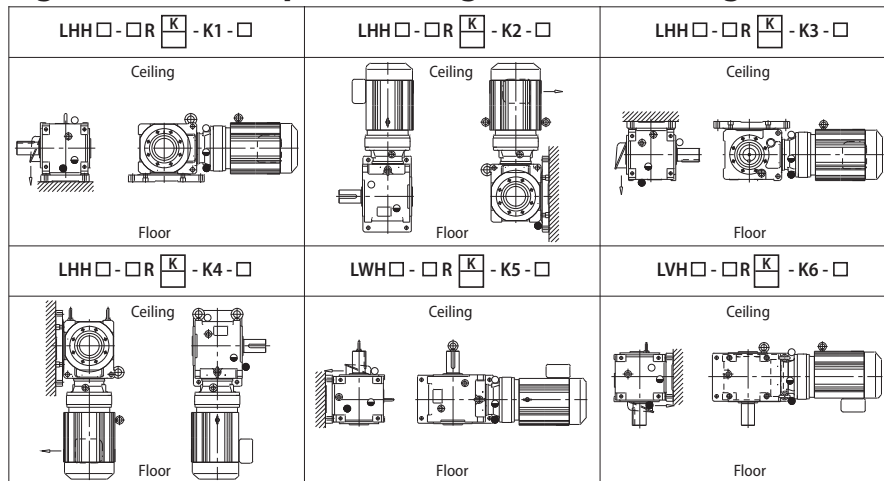
**Fig. 5.54 Solid Output Shaft Left (L) – Mounting Foot Bottom**



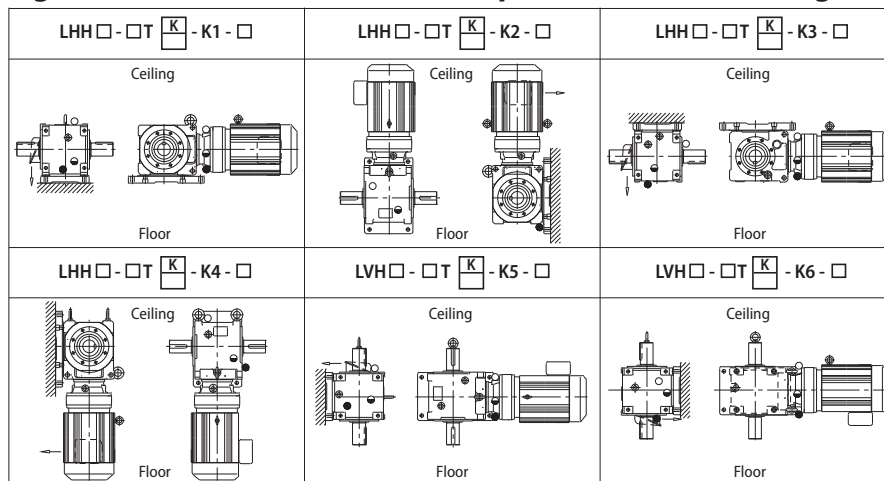
**Notes:** [1] **K** = inch diameter shaft or keyed hollow bore; **blank** = metric diameter shaft or keyed hollow bore.  
 [2] ○ = Oil Fill Location; ● = Oil Level Location; ● = Oil Drain Location.  
 [3] ← = direction of lead wires out of terminal box.

# Additional Mounting Configurations continued

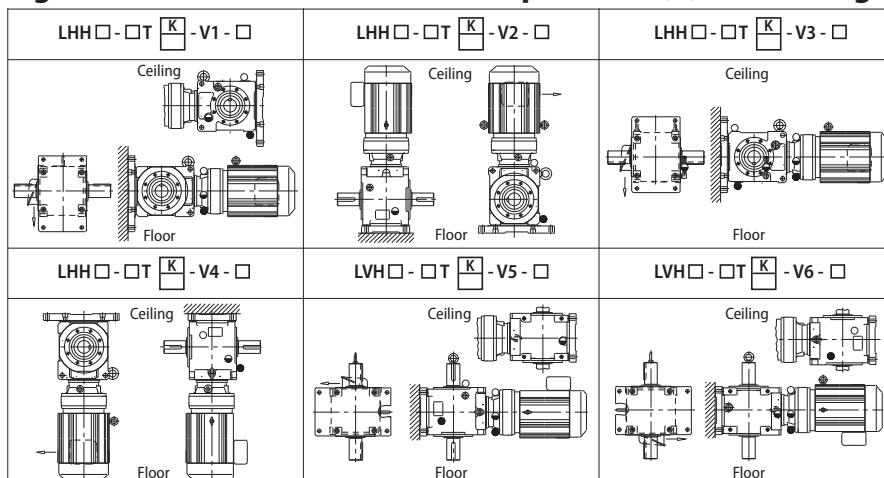
## Fig. 5.55 Solid Output Shaft Right (R) – Mounting Foot Bottom



## Fig. 5.56 Double Extended Solid Output Shaft (T) – Mounting Foot Bottom



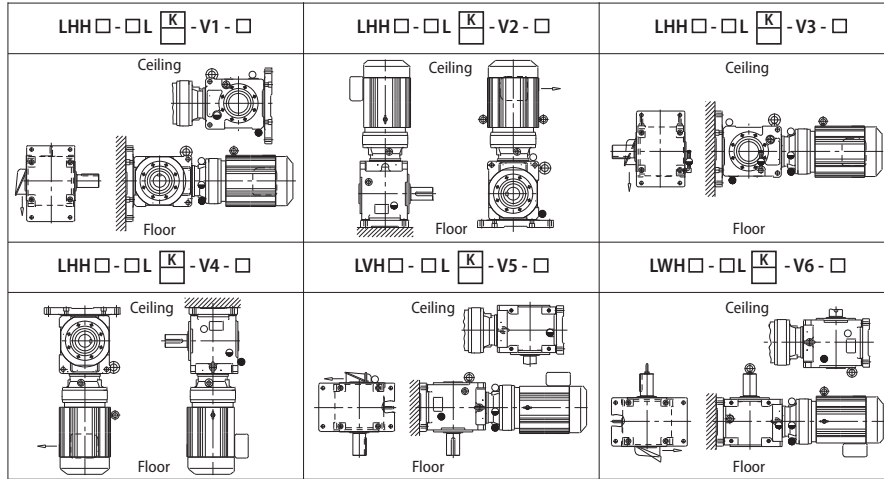
## Fig. 5.57 Double Extended Solid Output Shaft (T) – Mounting Foot Side



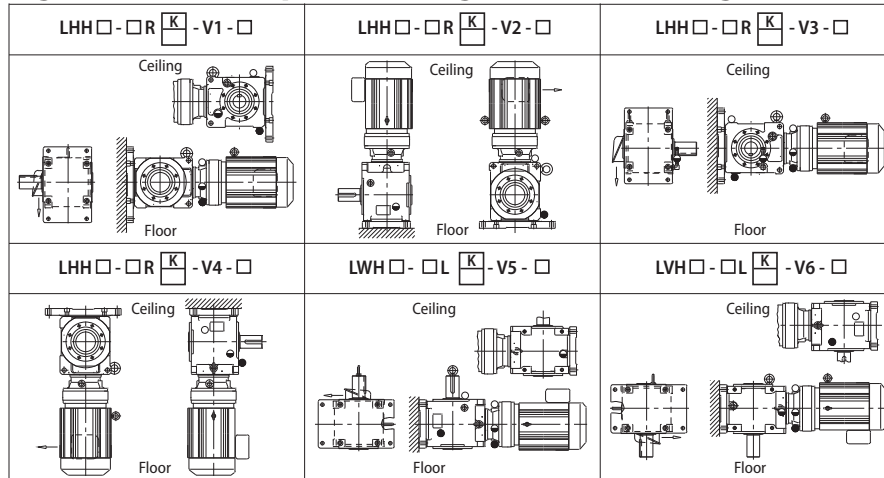
**Notes:** [1] K = inch diameter shaft or keyed hollow bore; **blank** = metric diameter shaft or keyed hollow bore.  
 [2] ○ = Oil Fill Location; ● = Oil Level Location; ● = Oil Drain Location.  
 [3] ← = direction of lead wires out of terminal box.

# Additional Mounting Configurations continued

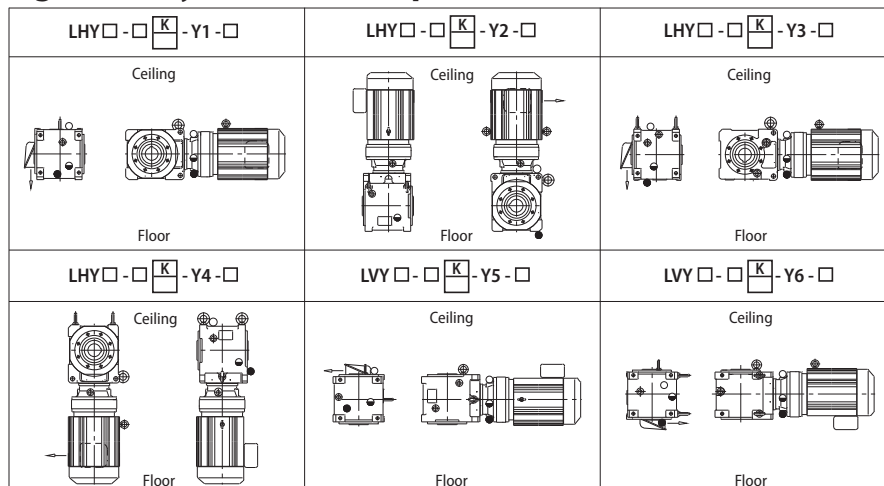
**Fig. 5.58 Solid Output Shaft Left (L) – Mounting Foot Side**



**Fig. 5.59 Solid Output Shaft Right (R) – Mounting Foot Side**



**Fig. 5.60 Keyed Hollow Output Bore**



**Notes:** [1] K = inch diameter shaft or keyed hollow bore; **blank** = metric diameter shaft or keyed hollow bore.  
 [2] ○ = Oil Fill Location; ● = Oil Level Location; ● = Oil Drain Location.  
 [3] ← = direction of lead wires out of terminal box.

Cyclo BBB

Appendix

# Warranty

---

Sumitomo warrants that its Cyclo BBB Speed Reducers will deliver their continuous catalog ratings and up to 300% intermittent SHOCK LOAD CAPACITY, provided they are properly installed, maintained and operated within the limits of speed, torque or other load conditions under which they were sold. Sumitomo further states that Cyclo BBB Speed Reducers are warranted to be free from defects in material or workmanship for a period of two years from the date of shipment. Sumitomo assumes no liability beyond product repair or replacement under this limited warranty.

For construction purposes, be sure to obtain certified dimension sheets or drawings. Although we take every precaution to include accurate data in our catalog, we cannot guarantee such accuracy. If performance guarantees are required, they should be obtained in writing from the factory. Full consideration will be given to such requests when complete details are given of the proposed installation.

# Notes

A large, empty grid for notes, consisting of approximately 40 columns and 25 rows of small squares. The grid is located below the 'Notes' section header.

Cyclo BBB  
**Appendix**



## Bottling/Baking



Steel hypoid gear technology, maintenance-free grease lubrication and a compact modular housing makes the Hyponic® an efficient performer in the food industry.

A 15-hp Beier mechanical variable speed drive with electric remote control provides an adjustable, steady speed range for this 350-ft. oven band conveyor.

## Water Treatment



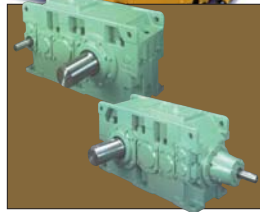
Each of these Sumitomo Paramax® speed reducers helps pump up to 13 million gallons a day at this state-of-the-art wastewater treatment facility in the City of Clearwater, Florida.

Cyclo® mixer drives are a key component of this award-winning water treatment facility in Hillsborough County, Florida.

## Material Handling



Sumitomo Paramax® reducers provide quiet, reliable operation for both the hoist and trolley drive systems in this 35-ton capacity DC Trolley Hoist used for heavy-duty coil handling service.



## Custom Designs



In less than 20 minutes, 96 Sumitomo Cyclo® Bevel Buddybox gearmotors help retract the 13,000-ton roof on Seattle's Safeco Field.

The Sumitomo gearmotors, on eight travel truck assemblies, turn 128 36° wheels.

## Wood Products



Sumitomo Cyclo® drives are an integral part of this manufacturing plant which produces 150,000 board feet of unfinished strip and plank hardwood flooring each week.

Once flooring is side-matched, it is inspected for defects. This conveyor, driven by Sumitomo Cyclo® drives, carries defective material to the hammer mill.

## Steel



After molten steel is formed in the five-strand continuous caster at this steel mill, it is conveyed by Sumitomo Cyclo® drives on the auto-torch conveyors where the steel is cut into billets.

## WORLDWIDE LOCATIONS

### Sumitomo Machinery Corporation of America

#### Headquarters & Manufacturing

4200 Holland Boulevard  
Chesapeake, VA 23323

**Tel: 757-485-3355 • 1-800-SMCYCLO**

**Fax: 757-485-7490**

[www.smcyclo.com](http://www.smcyclo.com)

E-mail: [customercare@suminet.com](mailto:customercare@suminet.com)



#### U.S. Sales and Support

##### Midwest

Sumitomo Machinery Corporation of America  
175 West Lake Drive  
Glendale Heights, IL 60139  
Tel: 630-752-0200 • 1-800-SMCYCLO  
Fax: 630-752-0208

##### West

Sumitomo Machinery Corporation of America  
2375 Railroad Street  
Corona, CA 92880-5411  
Tel: 951-340-4100 • 1-800-SMCYCLO  
Fax: 951-340-4108

#### Canada

##### Toronto (East)

SM-Cyclo of Canada, Ltd.  
1045 South Service Road, West  
Oakville, Ontario, Canada L6L 6K3  
Tel: 905-469-1050 • Fax: 905-469-1055

##### Vancouver (West)

SM-Cyclo of Canada, Ltd.  
740 Chester Road, Annacis Island, Delta  
B.C., Canada V3M 6J1  
Tel: 604-525-5403 • Fax: 604-525-0879

##### Montreal

SM-Cyclo of Canada, Ltd.  
2862 Blvd. Daniel-Johnson  
Laval, Quebec, Canada H7P 5Z7  
Tel: 450-686-8808 • Fax: 450-686-8000

#### World Headquarters

##### Japan

Sumitomo Heavy Industries, Ltd.  
Power Transmission & Controls Group  
ThinkPark Tower, 1-1, Osaki 2-chome,  
Shinagawa-ku, Tokyo 141-6025 Japan  
Tel: 011-813-6737-2511 • Fax: 011-813-6866-5160

For Worldwide contact information:

[www.sumitomodrive.com](http://www.sumitomodrive.com)

#### Mexico

##### Monterrey

SM-Cyclo de Mexico, S.A. de C.V.  
Calle "C" No. 506A  
Parque Industrial Almacentro  
Apodaca, N.L., Mexico 66600  
Tel: 011-52-81-8144-5130 • Fax: 011-52-81-8369-3699

##### Mexico City

SM-Cyclo de Mexico, S.A. de C.V.  
Privada Ceylan No. 59-B Bis  
Colonia Industrial Vallejo  
Delegacion Azcapotzalco, DF Mexico 02300  
Tel: 011-52-55-5368-7172 • Fax: 011-52-55-5368-6699

##### Guadalajara

SM-Cyclo de Mexico S.A. de C.V.  
Unidad Privativa No. 4  
Alamo Tecno Park  
Tlaquepapue, JAL CP 44490  
Tel: 011-52-33-3675-43-69 • Fax: 011-52-33-3675-4418

#### South America

##### Brazil

SM Cyclo Redutores do Brasil Comercio Ltda.  
Av. Fagundes Filho, 191  
Ed. Houston Office Center - c. j. H123  
CEP: 04304-010 - São Paulo, Brazil  
Tel: 011-55-11-5585-3600 • Fax: 011-55-11-5585-9990

##### Chile

Santiago  
SM Cyclo de Chile Ltda.  
San Pablo 3507  
Comuna de Quinta Normal - Santiago, Chile  
Tel: 011-562-892-7000 • Fax: 011-562-892-7001

##### Antofagasta

SM Cyclo de Chile Ltda.  
Calle 8, Manzana N2, Sitio 1  
Sector La Negra, Antofagasta, Chile  
Tel: 011-565-556-1611 • Fax: 011-565-556-1616

##### Concepción

SM Cyclo de Chile Ltda.  
Camino a Coronel Km 10, #5580, Modulo 3-A  
Comuna: San Pedro de la Paz - Concepción, Chile  
Tel: 011-41-246-98-06/07 • Fax: 011-41-246-98-08

##### Argentina

SM-Cyclo de Argentina SA  
Manuel Montes de Oca 6719  
B1606 BMG, Munro  
Buenos Aires, Argentina  
Tel: 011-54-11-4765-5332 • Fax: 011-54-11-4765-5517

#### Europe

##### Austria

##### Belgium

##### France

##### Germany

##### Italy

##### Spain

##### Sweden

##### United Kingdom

#### Asia

##### China

##### Hong Kong

##### Indonesia

##### Korea

##### Malaysia

##### Philippines

##### Singapore

##### Taiwan

##### Thailand

##### Vietnam

#### Other Locations

##### Australia

##### India

##### New Zealand