



LM Guide Actuator

KR



For details, visit THK at www.thk.com

*Product information is updated regularly on the THK website.

THK CO., LTD.
TOKYO, JAPAN

CATALOG No.209-10E

**Integrated LM Guide and Ball Screw
High-rigidity / High-precision Actuator**

LM Guide Actuator Model KR

Model No. KR15 to 65



Contents

LM Guide Actuator Model KR	3	Options	60
• Structure and Features	3	• Bellows	60 to 64, 85
• Types and Features	7	• Sensor	65 to 68, 86
• Load Ratings in All Directions and Static Permissible Moment ..	8	• Housing	69, 86
• Maximum Speeds with Different Strokes	13	• Intermediate Flange	70 to 83
• Lubrication	15	• Cover	85
• Static Safety Factor	16	• Motor Wrap Type	87
• Service Life	17	• XY Bracket (for Reference)	88
Example of Calculating the Nominal Life ..	20	Appendix	84
• Accuracy Standards	27	Precautions on Use	90
Model Number Coding	31		
Dimensional Drawing, Dimensional Table			
• Model KR15 Standard Type	33		
• Model KR15 (with a Cover)	34		
• Model KR20 Standard Type	35		
• Model KR20 (with a Cover)	36		
• Model KR26 Standard Type	37		
• Model KR26 (with a Cover)	38		
• Model KR30H Standard Type.....	39, 41		
• Model KR30H (with a Cover).....	40, 42		
• Model KR33 Standard Type	43, 45		
• Model KR33 (with a Cover)	44, 46		
• Model KR45H Standard Type.....	47, 49		
• Model KR45H (with a Cover).....	48, 50		
• Model KR46 Standard Type	51, 53		
• Model KR46 (with a Cover)	52, 54		
• Model KR55 Standard Type	55		
• Model KR55 (with a Cover)	56		
• Model KR65 Standard Type	57		
• Model KR65 (with a Cover)	58		
• Mass of Moving Element.....	59		

KR

LM Guide Actuator Model KR

LM Guide + Ball Screw = Integral-structure Actuator

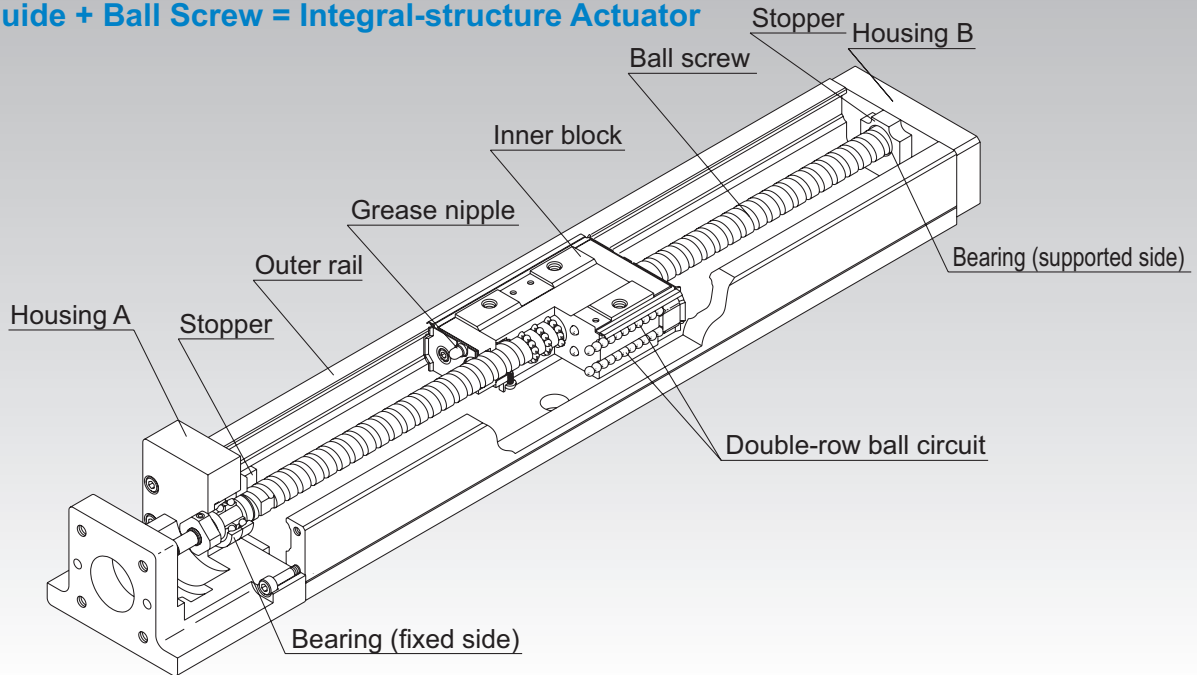

Fig.1 Structure of LM Guide Actuator Model KR

Structure and Features

Because of its integral-structure inner block consisting of a highly rigid outer rail with a U-shaped cross section, LM Guide units on both side faces and a Ball Screw unit in the center, LM Guide Actuator model KR achieves a highly rigid and highly accurate actuator in a minimal space.

In addition, since the housings A and B also serve as support units and the inner block as a table, this model allows significant reduction of man-hours required for design and assembly, thus contributing to total cost cutting.

[4-way Equal Load]

Each row of balls is arranged at a contact angle of 45° so that the rated load on the inner block is uniform under loads applied to the inner block in the four directions (radial, reverse radial and lateral directions). As a result, model KR can be used in any mounting orientation.

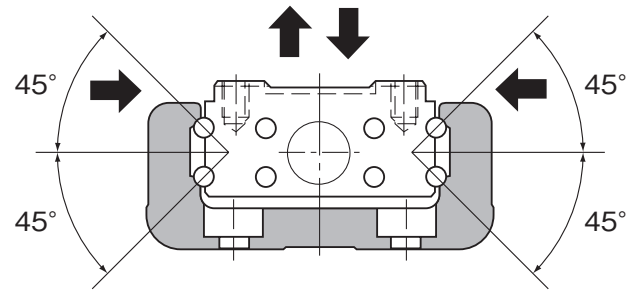

Fig.2 Load Capacity and Contact Angle of Model KR

[High Rigidity]

Use of an outer rail with a U-shaped cross section increases the rigidity against a moment and torsion.

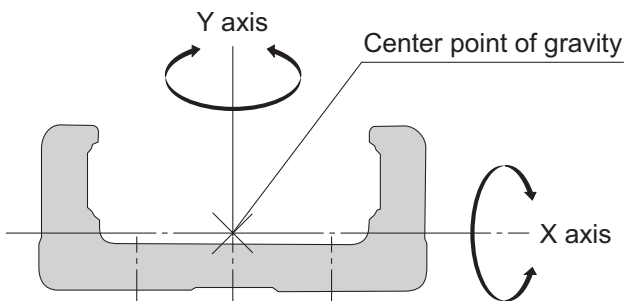

Fig.3 Cross Section of the Outer Rail

Table1 Cross-sectional Characteristics of the Outer rail Rail

Model No.	I_x [mm ⁴]	I_y [mm ⁴]	Mass [kg/m]
KR15	9.08×10^2	1.42×10^4	1.04
KR20	6.1×10^3	6.2×10^4	2.6
KR26	1.7×10^4	1.5×10^5	3.9
KR30H	2.7×10^4	2.8×10^5	5.0
KR33	6.2×10^4	3.8×10^5	6.6
KR45H	8.4×10^4	8.9×10^5	9.0
KR46	2.4×10^5	1.5×10^6	12.6
KR55	2.2×10^5	2.3×10^6	15.0
KR65	4.6×10^5	5.9×10^6	23.1

I_x =geometrical moment of inertia around X axis
 I_y =geometrical moment of inertia around Y axis

[High Accuracy]

Since the linear guide section consists of 4 rows of circular-arc grooves that enable balls to smoothly move even under a preload, a highly rigid guide with no clearance is achieved. Additionally, variation in frictional resistance caused by load fluctuation is minimized, allowing the system to follow highly accurate feed.

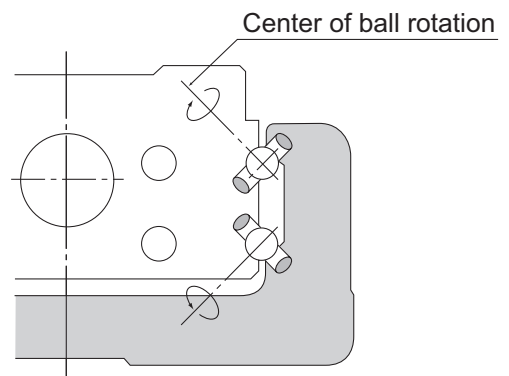

Fig.4 Contact Structure of Model KR

[Space Saving]

Use of an inner block integrating LM Guide units on both ends and a Ball Screw unit in the center makes model KR a highly rigid and highly accurate actuator in a minimal space.

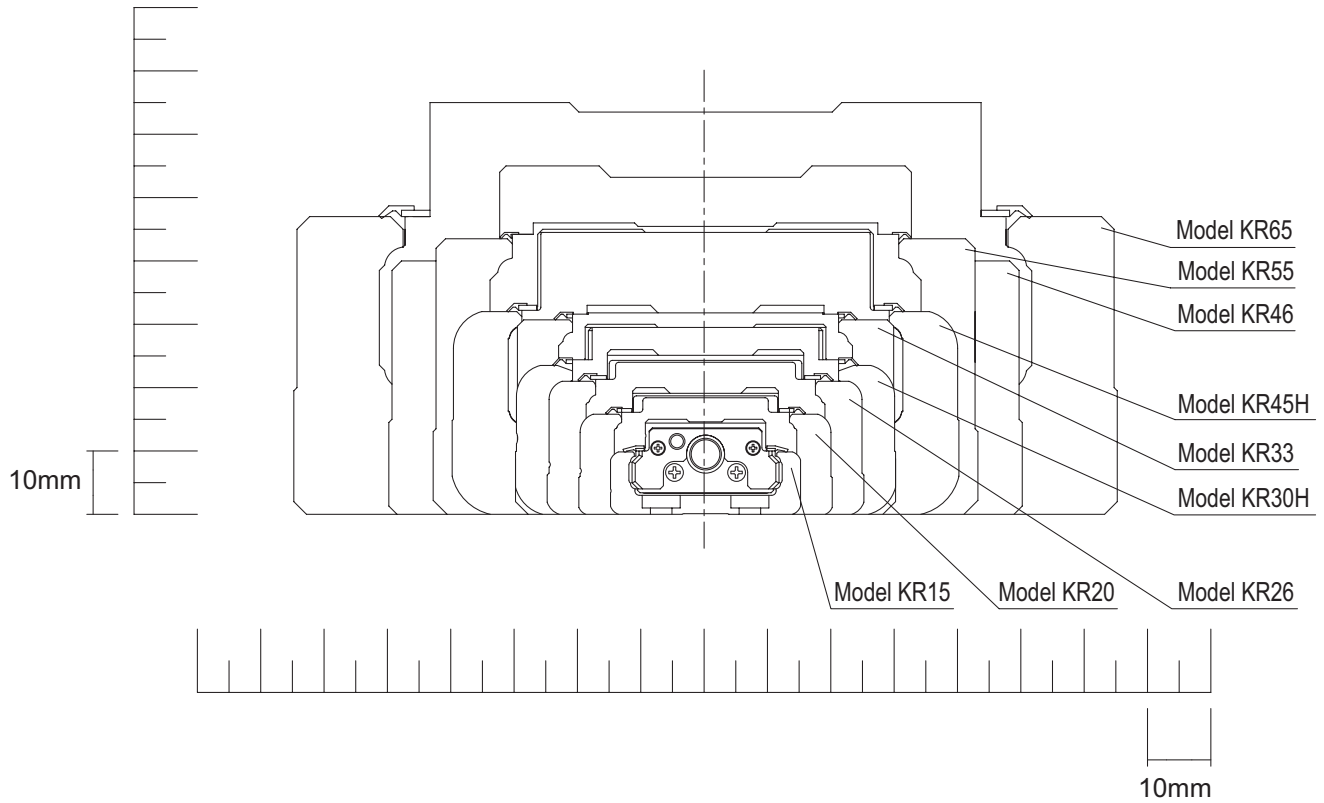

Fig.5 Cross Sectional Drawing

[Seal]

Model KR is equipped with end seals and side seals for dust prevention as standard.

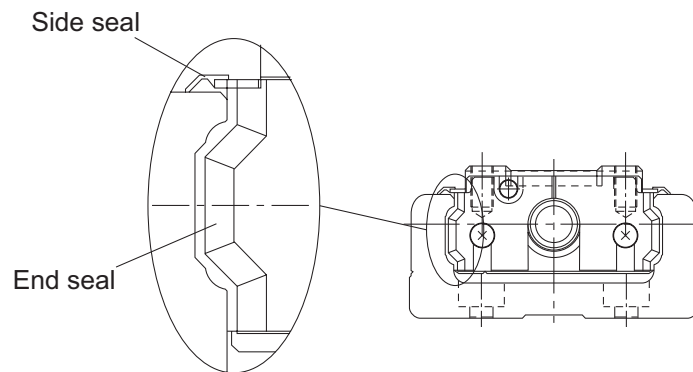

Table2 shows the rolling resistance and seal resistance per inner block (guide section).

Table2 Maximum Resistance Value Unit: N

Model No.	Rolling resistance value	Seal resistance value	Total
KR15	0.2	0.7	0.9
KR20	0.5	0.7	1.2
KR26	0.6	0.8	1.4
KR30H	1.5	2.0	3.5
KR33	1.5	1.9	3.4
KR45H	2.5	2.6	5.1
KR46	2.5	2.5	5
KR55	5.0	3.8	8.8
KR65	6.0	4.1	10.1

Note) The rolling resistance represents the value when a lubricant is not used.

Types and Features

Model KR-A (with a Single Long Type Block)

Representative model of KR.

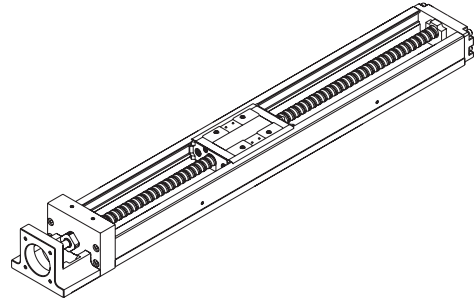

Model KR-A

Model KR-B (with Two Long Type Blocks)

Equipped with two units of the inner block of model KR-A, this model achieves higher rigidity and higher load carrying capacity.

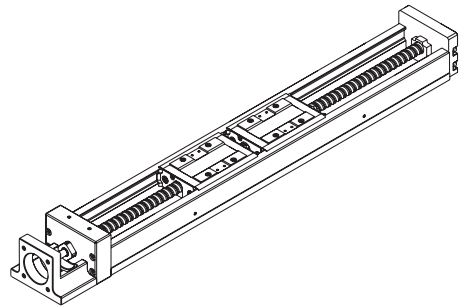

Model KR-B

Model KR-C (with a Single Short Type Block)

This model has a shorter overall length of the inner block and a longer stroke than model KR-A. (Supported models: model KR30H, 33, 45H, 46)

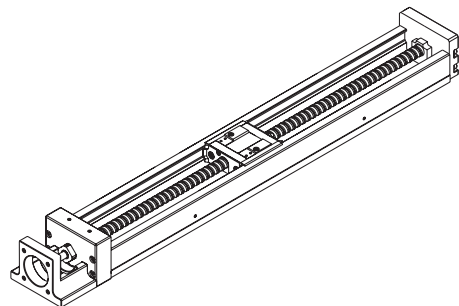

Model KR-C

Model KR-D (with Two Short Type Blocks)

Equipped with two units of the inner block of model KR-C, this design allows a span between blocks that suits the equipment, thus to achieve high rigidity. (Supported models: model KR30H, 33, 45H, 46)

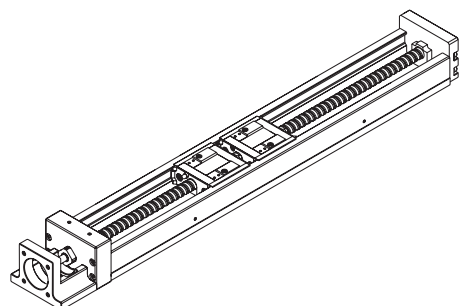

Model KR-D

Load Ratings in All Directions and Static Permissible Moment

[Load Rating]

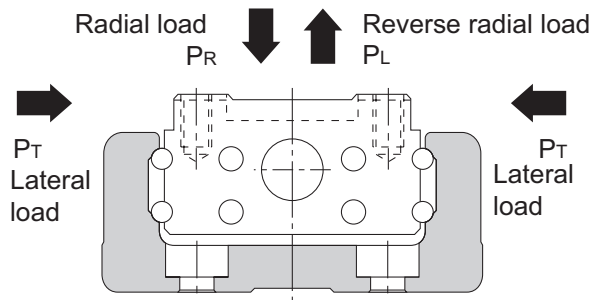

● LM Guide Unit

Model KR is capable of receiving loads in four directions (radial, reverse radial and lateral directions). Its basic load ratings are equal in all four directions (radial, reverse radial and lateral directions), and their values are indicated in Table3 on page9 and page10.

● Ball Screw Unit

Since the inner block is incorporated with a ball screw nut, model KR is capable of receiving an axial load. The basic load rating value is indicated in Table3 on page9 and page10.

● Bearing Unit (Fixed Side)

Since housing A contains an angular bearing, model KR is capable of receiving an axial load. The basic load rating value is indicated in Table3 on page9 and page10.

[Equivalent Load (LM Guide Unit)]

The equivalent load when the LM Guide unit of model KR simultaneously receives loads in all directions is obtained from the following equation.

$$P_E = P_R (P_L) + P_T$$

P_E	: Equivalent load	(N)
	: Radial direction	
	: Reverse radial direction	
	: Lateral direction	
P_R	: Radial load	(N)
P_L	: Reverse radial load	(N)
P_T	: Lateral load	(N)

Table3 Load Rating of Model KR

Model No.			KR15		KR20		KR26		
			KR1501	KR1502	KR2001	KR2006	KR2602	KR2606	
LM guide unit	Basic dynamic load rating C (N)	Long type block	1930		3590		7240		
		Short type block	—		—		—		
	Basic static load rating C ₀ (N)	Long type block	3450		6300		12150		
		Short type block	—		—		—		
	Radial clearance (mm)	Normal grade, high accuracy grade	-0.001 to +0.002		-0.003 to +0.002		-0.004 to +0.002		
		Precision grade	-0.005 to -0.002		-0.007 to -0.003		-0.01 to -0.004		
Ball screw unit	Basic dynamic load rating C _a (N)	Normal grade, high accuracy grade	340	230	660	860	2350	1950	
		Precision grade	340	230	660	1060	2350	2390	
	Basic static load rating C _{0a} (N)	Normal grade, high accuracy grade	660	410	1170	1450	4020	3510	
		Precision grade	660	410	1170	1600	4020	3900	
	Screw shaft diameter (mm)		5		6		8		
	Lead (mm)		1	2	1	6	2	6	
	Thread minor diameter (mm)		4.5		5.3	5.0	6.6	6.7	
	Ball center-to-center diameter (mm)		5.15		6.15	6.3	8.3	8.4	
Bearing unit (Fixed side)	Axial direction	Basic dynamic load rating C _a (N)	590		1000		1380		
		Static permissible load P _{0a} (N)	290		1240		1760		

Note1) The load ratings in the LM Guide unit each indicate the load rating per inner block.

Note2) The Ball Screw of precision grade (grade P) for models KR30H, KR33, KR45H10 and KR4610 is incorporated with spacer balls in the proportion of one to one.

Note3) The Ball Screw of precision grade (grade P) for models KR45H20, KR4620, KR55 and KR65 is incorporated with spacer balls in the proportion of two to one.

	KR30H		KR33		KR45H		KR46		KR55	KR65
	KR30H06	KR30H10	KR3306	KR3310	KR45H10	KR45H20	KR4610	KR4620		
	11600		11600		23300		27400		38100	50900
	4900		4900		11900		14000		—	—
	20200		20200		39200		45500		61900	80900
	10000		10000		19600		22700		—	—
	-0.004 to +0.002		-0.004 to +0.002		-0.006 to +0.003		-0.006 to +0.003		-0.007 to +0.004	-0.008 to +0.004
	-0.012 to -0.004		-0.012 to -0.004		-0.016 to -0.006		-0.016 to -0.006		-0.019 to -0.007	-0.022 to -0.008
	2840	1760	2840	1760	3140	3040	3140	3040	3620	5680
	2250	1370	2250	1370	2940	3430	2940	3430	3980	5950
	4900	2840	4900	2840	6760	7150	6760	7150	9290	14500
	2740	1570	2740	1570	3720	5290	3720	5290	6850	10700
	10		10		15		15		20	25
	6	10	6	10	10	20	10	20	20	25
	7.8		7.8		12.5		12.5		17.5	22
	10.5		10.5		15.75		15.75		20.75	26
	1790		1790		6660		6660		7600	13700
	2590		2590		3240		3240		3990	5830

[Static Permissible Moment (LM Guide Unit)]

The Inner block is capable of receiving moment loads in all three (3) directions.
 Table4 on page12 shows static permissible moments in the M_A , M_B and M_C directions.

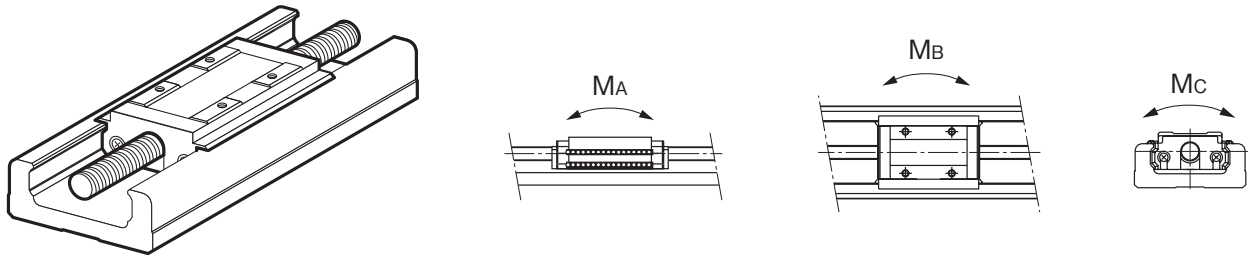

With a single long type block (Model KR-A)

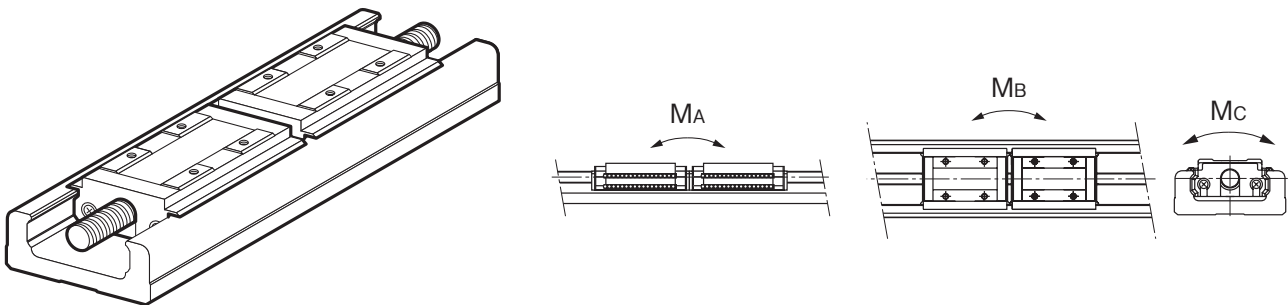

With double long type blocks (Model KR-B)

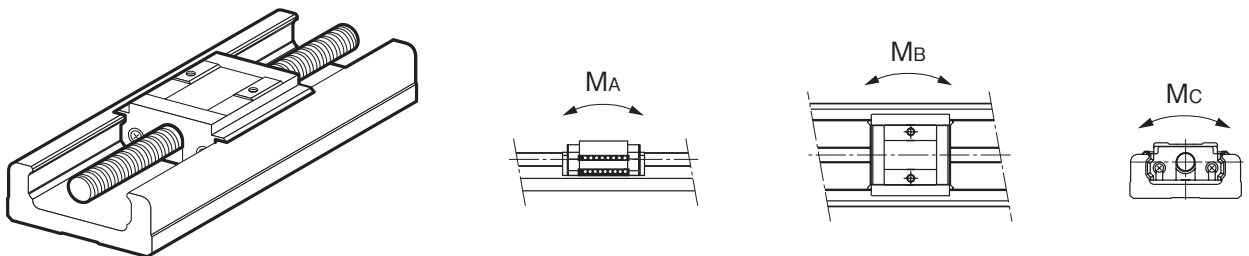

With a single long type block (Model KR-C)

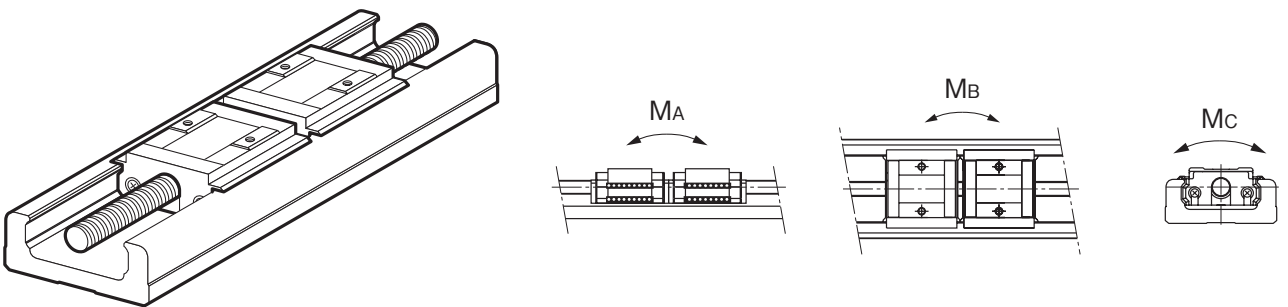

With double long type blocks (Model KR-D)

Table4 Static Permissible Moments of Model KR

Unit: N·m

Model No.	Static permissible moment		
	M _A	M _B	M _C
KR15-A	12.1	12.1	38
KR15-B	70.3	70.3	76
KR20-A	31	31	83
KR20-B	176	176	165
KR26-A	84	84	208
KR26-B	480	480	416
KR30H-A	166	166	428
KR30H-B	908	908	857
KR30H-C	44	44	214
KR30H-D	319	319	427
KR33-A	166	166	428
KR33-B	908	908	857
KR33-C	44	44	214
KR33-D	319	319	427
KR45H-A	486	486	925
KR45H-B	2732	2732	1850
KR45H-C	130	130	463
KR45H-D	994	994	925
KR46-A	547	547	1400
KR46-B	2940	2940	2800
KR46-C	149	149	700
KR46-D	1010	1010	1400
KR55-A	870	870	2280
KR55-B	4890	4890	4570
KR65-A	1300	1300	3920
KR65-B	7230	7230	7840

Note1) Symbols A, B, C or D in the end of each model number indicates the inner block size and the number of inner blocks used.

- A: With a single long type block
- B: With double long type blocks
- C: With a single short type block
- D: With double short type blocks

Note2) The values for models KR-B/D indicate the values when double inner blocks are used in close contact with each other.

Note3) Static permissible moment is the maximum moment that can be permitted while the product is stationary.

Maximum Speeds with Different Strokes

Table5 Maximum speed

Model No.	Ball Screw lead (mm)	Stroke (mm)		Outer rail length (mm)	Maximum speed (mm/s)					
					Precision grade	High accuracy grade	Normal grade	Precision grade	High accuracy grade	Normal grade
		Long type block	Short type block		Long type block			Short type block		
KR15	01	25	—	75	100	100	—	—	—	
		50	—	100	100	100	—	—		
		75	—	125	100	100	—	—		
		100	—	150	100	100	—	—		
		125	—	175	100	100	—	—		
	02	150	—	200	100	100	—	—		
		25	—	75	200	200	—	—		
		50	—	100	200	200	—	—		
		75	—	125	200	200	—	—		
		100	—	150	200	200	—	—		
KR20	01	30	—	100	100	100	—	—		
		80	—	150	100	100	—	—		
		130	—	200	100	100	—	—		
	06	30	—	100	600	600	—	—		
		80	—	150	600	600	—	—		
		130	—	200	600	600	—	—		
KR26	02	60	—	150	200	200	—	—		
		110	—	200	200	200	—	—		
		160	—	250	200	200	—	—		
		210	—	300	200	200	—	—		
	06	60	—	150	600	590	—	—		
		110	—	200	600	590	—	—		
		160	—	250	600	590	—	—		
		210	—	300	600	590	—	—		
KR30H	06	50	70	150	600	470	600	470		
		100	120	200	600	470	600	470		
		200	220	300	600	470	600	470		
		300	320	400	600	470	600	470		
		400	420	500	590	470	530	470		
	10	500	520	600	395	395	360	360		
		50	70	150	1000	790	1000	790		
		100	120	200	1000	790	1000	790		
		200	220	300	1000	790	1000	790		
		300	320	400	1000	790	1000	790		
KR33	06	400	420	500	980	790	880	790		
		500	520	600	650	650	600	600		
		50	75	150	600	470	600	470		
		100	125	200	600	470	600	470		
		200	225	300	600	470	600	470		
		300	325	400	600	470	600	470		
	10	400	425	500	590	470	530	470		
		500	525	600	395	395	360	360		
		600	625	700	280	280	260	260		
		50	75	150	1000	790	1000	790		
		100	125	200	1000	790	1000	790		
		200	225	300	1000	790	1000	790		
10	300	325	400	1000	790	1000	790			
	400	425	500	980	790	880	790			
	500	525	600	650	650	600	600			
	600	625	700	470	470	430	430			

Model No.	Ball Screw lead (mm)	Stroke* (mm)		Outer rail length (mm)	Maximum speed (mm/s)					
					Precision grade	High accuracy grade	Normal grade	Precision grade	High accuracy grade	Normal grade
		Long type block	Short type block		Long type block			Short type block		
KR45H	10	200	230	340	740	520	740	520		
		300	330	440	740	520	740	520		
		400	430	540	740	520	740	520		
		500	530	640	740	520	740	520		
		600	630	740	730	520	640	520		
		700	730	840	—	520	—	490		
		800	830	940	—	430	—	380		
	20	200	230	340	1480	1050	1480	1050		
		300	330	440	1480	1050	1480	1050		
		400	430	540	1480	1050	1480	1050		
		500	530	640	1480	1050	1480	1050		
		600	630	740	1430	1050	1280	1050		
		700	730	840	—	1050	—	980		
		800	830	940	—	840	—	770		
KR46	10	190	220	340	740	520	740	520		
		290	320	440	740	520	740	520		
		390	420	540	740	520	740	520		
		490	520	640	740	520	740	520		
		590	620	740	730	520	650	520		
		690	720	840	—	520	—	490		
		790	820	940	—	430	—	390		
	20	190	220	340	1480	1050	1480	1050		
		290	320	440	1480	1050	1480	1050		
		390	420	540	1480	1050	1480	1050		
		490	520	640	1480	1050	1480	1050		
		590	620	740	1440	1050	1300	1050		
		690	720	840	—	1050	—	990		
		790	820	940	—	850	—	780		
KR55	20	800	—	980	1120	800	—			
		900	—	1080	900	800	—			
		1000	—	1180	740	740	—			
		1100	—	1280	—	620	—			
		1200	—	1380	—	530	—			
KR65	25	790	—	980	1120	800	—			
		990	—	1180	1120	800	—			
		1190	—	1380	840	800	—			
		1490	—	1680	—	550	—			

*Indicates a stroke when one inner block is incorporated.

Note1) The maximum speed is the value restricted by the motor rotation speed (at 6,000 min⁻¹), or by the permissible rotation speed of the Ball Screw.

Note2) If you are considering using this product at the maximum travel speed of Table5 or faster, contact THK.

Lubrication

Table6 shows standard greases used in model KR and grease nipple types.

Table6 Types of standard grease and grease nipples used

Model No.	Standard grease	Grease nipple used
KR15	THK AFF Grease	—
KR20	THK AFA Grease	PB107
KR26	THK AFA Grease	PB107
KR30H	THK AFB-LF Grease	PB107
KR33	THK AFB-LF Grease	PB107
KR45H	THK AFB-LF Grease	A-M6F
KR46	THK AFB-LF Grease	A-M6F
KR55	THK AFB-LF Grease	A-M6F
KR65	THK AFB-LF Grease	A-M6F

Static Safety Factor

LM Guide Actuator Model KR consists of an LM Guide, a Ball Screw and a support bearing. The static safety factor and the service life of each component can be obtained from the basic load rating indicated in "Rated load of model KR" (see Table3 on page9).

[Calculating the Static Safety Factor]

● LM Guide Unit

To calculate a load applied to the LM Guide of model KR, the average load required for calculating the service life and the maximum load needed for calculating the static safety factor must be obtained first. In particular, if the system starts and stops frequently, or if a large moment caused by an overhung load is applied to the system, it may receive an unexpectedly large load.

When selecting a model number, make sure that the desired model is capable of receiving the required maximum load (whether stationary or in motion).

$$f_s = \frac{C_0}{P_{max}}$$

f_s : Static safety factor

C_0 : Basic static load rating (N)

P_{max} : Maximum applied load (N)

*The basic static load rating is a static load with a constant direction and magnitude whereby the sum of the permanent deformation of the rolling element and that of the raceway on the contact area under the maximum stress is 0.0001 times the rolling element diameter.

● Ball Screw Unit/Bearing Unit(Fixed Side)

If an unexpected external force is applied in the axial direction as a result of an inertia caused by an impact or start and stop while model KR is stationary or operating, it is necessary to take into account the static safety factor.

$$f_s = \frac{C_{0a}}{F_{max}}$$

f_s : Static safety factor

C_{0a} : Basic static load rating (N)

F_{max} : Maximum applied load (N)

[Standard Values for the Static Safety Factor (f_s)]

Machine type	Load conditions	Minimum Static Safety Factor (f_s)
General industrial machinery	Without vibration or impact	1.0 to 3.5
	With vibration or impact	2.0 to 5.0

*The standard value of the static safety factor may vary depending on the load conditions as well as environment, lubrication status, mounting accuracy, and/or rigidity.

Service Life

[LM Guide Unit]

● Nominal Life

$$L = \left(\frac{f_c \cdot C}{f_w \cdot P_c} \right)^3 \times 50$$

- L : Nominal life (km)
(The total travel distance that 90% of a group of identical LM Guide units independently operating under the same conditions can achieve without showing flaking)
- C : Basic dynamic load rating (N)
- P_c : Calculated applied load (N)
- f_w : Load factor (see Table8 on page19)
- f_c : Contact factor (see Table7 on page19)

- If a moment is applied to model KR-A/C or model KR-B/D using two inner blocks in close contact with each other, calculate the equivalent load by multiplying the applied moment by the equivalent factor indicated in Table9 on page19.

$$P_m = K \cdot M$$

- P_m : Equivalent load (per inner block) (N)
- K : Equivalent moment factor (see Table9 on page19)
- M : Applied moment (N-mm)
(If planning to use the product with a wide inner block span, contact THK.)

- If moment M_c is applied to model KR-B/D

$$P_m = \frac{K_c \cdot M_c}{2}$$

- If a radial load (P) and a moment are simultaneously applied to model KR

$$P_E = P_m + P$$

- P_E : Total equivalent radial load (N)
Perform a nominal life calculation using the above data.

● Service Life Time

When the nominal life (L) has been obtained, the service life time is obtained using the following equation (if the stroke length and the number of reciprocations per minute are constant).

$$L_h = \frac{L \times 10^6}{2 \cdot \ell_s \cdot n_1 \times 60}$$

L_h : Service life time (h)
 ℓ_s : Stroke length (mm)
 n_1 : Number of reciprocations per minute (min^{-1})

[Ball Screw Unit/Bearing Unit(Fixed Side)]

● Nominal Life

$$L = \left(\frac{C_a}{f_w \cdot F_a} \right)^3 \times 10^6$$

L : Nominal life (rev)
 (The total number of revolutions that 90% of a group of identical Ball Screw units independently operating under the same conditions can achieve without showing flaking)
 C_a : Basic dynamic load rating (N)
 F_a : Applied load (N)
 f_w : Load factor (see Table8 on page19)

● Service Life Time

When the nominal life (L) has been obtained, the service life time is obtained using the following equation (if the stroke length and the number of reciprocations per minute are constant).

$$L_h = \frac{L \cdot \ell}{2 \cdot \ell_s \cdot n_1 \times 60}$$

L_h : Service life time (h)
 ℓ_s : Stroke length (mm)
 n_1 : Number of reciprocations per minute (min^{-1})
 ℓ : Ball Screw lead (mm)

■f_c: Contact Factor

If two inner blocks are used in close contact with each other with model KR-B/D, multiply the basic load rating by the corresponding contact factor indicated in Table7.

Table7 Contact Factor (f_c)

Inner block types	Contact factor f _c
Model KR-B Model KR-D	0.81

■f_w: Load Factor

Table8 shows load factors.

Table8 Load Factor (f_w)

Vibrations/impact	Speed(V)	f _w
Faint	Very low V ≤ 0.25m/s	1 to 1.2
Weak	Slow 0.25 < V ≤ 1m/s	1.2 to 1.5
Medium	Medium 1 < V ≤ 2m/s	1.5 to 2
Strong	High V > 2m/s	2 to 3.5

■K: Moment Equivalent Factor (LM Guide Unit)

When model KR travels under a moment, the distribution of load applied to the LM Guide is locally large. In such cases, calculate the load by multiplying the moment value by the corresponding moment equivalent factor indicated in Table9.

Symbols K_A, K_B and K_C indicate the moment equivalent loads in the M_A, M_B and M_C directions, respectively.

Table9 Equivalent moment factor(K)

Model No.	K _A	K _B	K _C
KR15-A	3.2 × 10 ⁻¹	3.2 × 10 ⁻¹	9.09 × 10 ⁻²
KR15-B	5.96 × 10 ⁻²	5.96 × 10 ⁻²	9.09 × 10 ⁻²
KR20-A	2.4 × 10 ⁻¹	2.4 × 10 ⁻¹	7.69 × 10 ⁻²
KR20-B	4.26 × 10 ⁻²	4.26 × 10 ⁻²	7.69 × 10 ⁻²
KR26-A	1.73 × 10 ⁻¹	1.73 × 10 ⁻¹	5.88 × 10 ⁻²
KR26-B	3.06 × 10 ⁻²	3.06 × 10 ⁻²	5.88 × 10 ⁻²
KR30H-A	1.51 × 10 ⁻¹	1.51 × 10 ⁻¹	4.78 × 10 ⁻²
KR30H-B	2.76 × 10 ⁻²	2.76 × 10 ⁻²	4.78 × 10 ⁻²
KR30H-C	2.77 × 10 ⁻¹	2.77 × 10 ⁻¹	4.78 × 10 ⁻²
KR30H-D	3.99 × 10 ⁻²	3.99 × 10 ⁻²	4.78 × 10 ⁻²
KR33-A	1.51 × 10 ⁻¹	1.51 × 10 ⁻¹	4.93 × 10 ⁻²
KR33-B	2.57 × 10 ⁻²	2.57 × 10 ⁻²	4.93 × 10 ⁻²
KR33-C	2.77 × 10 ⁻¹	2.77 × 10 ⁻¹	4.93 × 10 ⁻²
KR33-D	3.55 × 10 ⁻²	3.55 × 10 ⁻²	4.93 × 10 ⁻²
KR45H-A	9.83 × 10 ⁻²	9.83 × 10 ⁻²	3.45 × 10 ⁻²
KR45H-B	1.87 × 10 ⁻²	1.87 × 10 ⁻²	3.45 × 10 ⁻²
KR45H-C	1.83 × 10 ⁻¹	1.83 × 10 ⁻¹	3.45 × 10 ⁻²
KR45H-D	2.81 × 10 ⁻²	2.81 × 10 ⁻²	3.45 × 10 ⁻²
KR46-A	1.01 × 10 ⁻¹	1.01 × 10 ⁻¹	3.38 × 10 ⁻²
KR46-B	1.78 × 10 ⁻²	1.78 × 10 ⁻²	3.38 × 10 ⁻²
KR46-C	1.85 × 10 ⁻¹	1.85 × 10 ⁻¹	3.38 × 10 ⁻²
KR46-D	2.5 × 10 ⁻²	2.5 × 10 ⁻²	3.38 × 10 ⁻²
KR55-A	8.63 × 10 ⁻²	8.63 × 10 ⁻²	2.83 × 10 ⁻²
KR55-B	1.53 × 10 ⁻²	1.53 × 10 ⁻²	2.83 × 10 ⁻²
KR65-A	7.55 × 10 ⁻²	7.55 × 10 ⁻²	2.14 × 10 ⁻²
KR65-B	1.35 × 10 ⁻²	1.35 × 10 ⁻²	2.14 × 10 ⁻²

Note) The values for models KR-B/D indicate the values when double inner blocks are used in close contact with each other.

Example of Calculating the Nominal Life

[Condition (Horizontal Installation)]

- Assumed model number : KR 5520A
- LM Guide unit (C = 38100N, C₀ = 61900N)
- Ball Screw unit (C_a = 3620N, C_{0a} = 9290N)
- Bearing unit(Fixed Side) (C_a = 7600N, P_{0a} = 3990N)
- Mass : m = 30kg
- Speed : v = 500mm/s
- Acceleration : α = 2.4m/s²
- Stroke : l_s = 1200mm
- Gravitational acceleration : g = 9.807m/s²
- Velocity diagram : see Fig.1

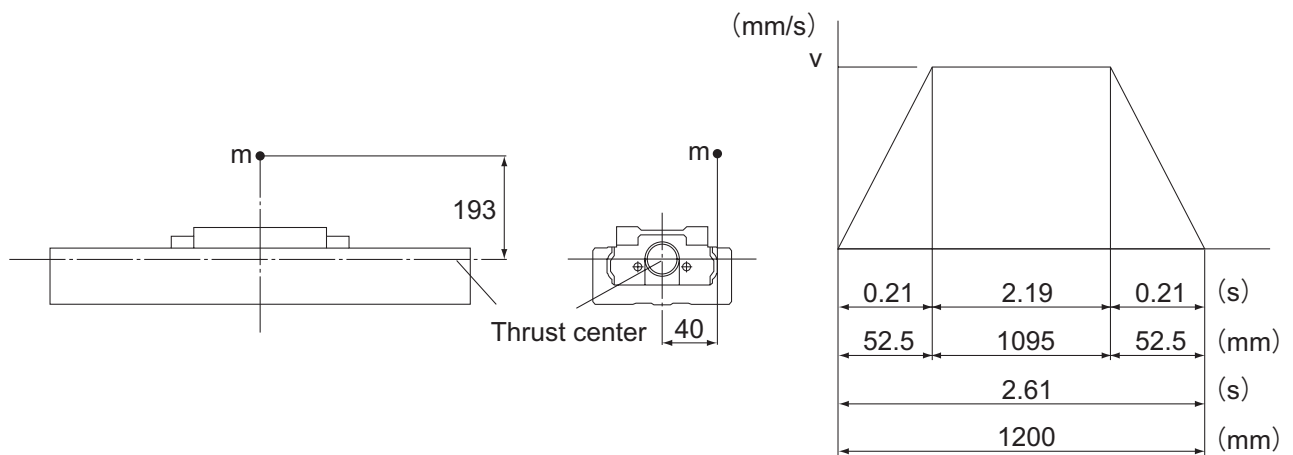

Fig.1 Velocity Diagram

[Consideration]

● Studying the LM Guide Unit

■ Load Applied to the Inner Block

- * Assuming that a single inner block is used, convert applied moments M_A and M_B into applied load by multiplying them by the moment equivalent factor (K_A = K_B = 8.63 × 10⁻²).
- * Assuming that a single shaft is used, convert applied moment M_C into applied load by multiplying it by the moment equivalent factor (K_C = 2.83 × 10⁻²).

● During uniform motion:

$$P_1 = mg + K_C \cdot mg \times 40 = 627 \text{ N}$$

● During acceleration:

$$P_{1a} = P_1 + K_A \cdot m\alpha \times 193 = 1826 \text{ N}$$

$$P_{1aT} = -K_B \cdot m\alpha \times 40 = -249 \text{ N}$$

● During deceleration:

$$P_{1d} = P_1 - K_A \cdot m\alpha \times 193 = -572 \text{ N}$$

$$P_{1dT} = K_B \cdot m\alpha \times 40 = 249 \text{ N}$$

- * Since the groove under a load is different from the assumed groove, give "0" (zero) to P_{1aT} and P_{1d}.

■ Combined Radial And Thrust Load

- During uniform motion:

$$P_{1E} = P_1 = 627 \text{ N}$$

- During acceleration:

$$P_{1aE} = P_{1a} + P_{1aT} = 1826 \text{ N}$$

- During deceleration:

$$P_{1dE} = P_{1d} + P_{1dT} = 249 \text{ N}$$

■ Static Safety Factor

$$f_s = \frac{C_0}{P_{\max}} = \frac{C_0}{P_{1aE}} = 33.9$$

■ Nominal Life

- Average load

$$P_m = \sqrt[3]{\frac{1}{\ell_s} (P_{1E}^3 \times 1095 + P_{1aE}^3 \times 52.5 + P_{1dE}^3 \times 52.5)} = 790 \text{ N}$$

- Nominal life

$$L = \left(\frac{C}{f_w \cdot P_m} \right)^3 \times 50 = 3.25 \times 10^6 \text{ km}$$

$$f_w \quad : \text{ Load factor} \quad (1.2)$$

● Studying the Ball Screw Unit

■ Axial load

- During forward uniform motion:

$$Fa_1 = \mu \cdot mg + f = 11 \text{ N}$$

μ : Friction coefficient(0.005)

f : Rolling resistance of one KR inner block + seal resistance(10.0 N)

- During forward acceleration:

$$Fa_2 = Fa_1 + m\alpha = 83 \text{ N}$$

- During forward deceleration:

$$Fa_3 = Fa_1 - m\alpha = -61 \text{ N}$$

- During uniform backward motion

$$Fa_4 = -Fa_1 = -11 \text{ N}$$

- During backward acceleration:

$$Fa_5 = Fa_4 - m\alpha = -83 \text{ N}$$

- During backward deceleration:

$$Fa_6 = Fa_4 + m\alpha = 61 \text{ N}$$

* Since the groove under a load is different from the assumed groove, give "0" (zero) to Fa_3 , Fa_4 and Fa_5 .

■ Static Safety Factor

$$f_s = \frac{C_{0a}}{F_{a\max}} = \frac{C_{0a}}{Fa_2} = 111.9$$

■Buckling Load

$$P_1 = \frac{n \cdot \pi^2 \cdot E \cdot I}{\ell_a^2} \times 0.5 = 11000 \text{ N}$$

P_1	: Buckling load	(N)
ℓ_a	: Distance between two mounting surfaces	(1300 mm)
E	: Young's modulus	($2.06 \times 10^5 \text{ N/mm}^2$)
n	: Factor for mounting method	(fixed-fixed: 4.0)
0.5	: Safety factor	
I	: Minimum geometrical moment of inertia of the shaft	(mm^4)

$$I = \frac{\pi}{64} \cdot d_1^4$$

d_1	: Screw-shaft thread minor diameter	(17.5 mm)
-------	-------------------------------------	-----------

■Permissible tensile Compressive Load

$$P_2 = \delta \cdot \frac{\pi}{4} \cdot d_1^2 = 35300 \text{ N}$$

P_2	: Permissible tensile compressive load	(N)
δ	: Permissible tensile compressive stress	(147 N/mm^2)
d_1	: Screw-shaft thread minor diameter	(17.5mm)

■Dangerous Speed

$$N_1 = \frac{60 \cdot \lambda^2}{2\pi \cdot \ell_b^2} \cdot \sqrt{\frac{E \times 10^3 \cdot I}{\gamma \cdot A}} \times 0.8 = 1560 \text{ min}^{-1}$$

N_1	: Dangerous speed	(min^{-1})
ℓ_b	: Distance between two mounting surfaces	(1300mm)
γ	: Density	($7.85 \times 10^{-6} \text{ kg/mm}^3$)
λ	: Factor according to the mounting method (fixed-supported 3.927)	
0.8	: Safety factor	

■DN Value

$$DN=31125(\leq 50000)$$

D	: Ball center-to-center diameter	(20.75mm)
N	: Maximum working rotation speed	(1500 min^{-1})

■Nominal Life

- Average axial load

$$F_{am} = \sqrt[3]{\frac{1}{2 \cdot \ell_s} (F_{a1}^3 \times 1095 + F_{a2}^3 \times 52.5 + F_{a6}^3 \times 52.5)} = 26.2 \text{ N}$$

- Nominal life

$$L = \left(\frac{C_a}{f_w \cdot F_{am}} \right)^3 \cdot \ell = 3.05 \times 10^7 \text{ km}$$

f_w	: Load factor	(1.2)
ℓ	: Ball Screw lead	(20mm)

● **Bearing Unit (Fixed Side)**

■ **Axial Load (Same as the Ball Screw Unit)**

- Fa₁ = 11 N
- Fa₂ = 83 N
- Fa₃ = 0 N
- Fa₄ = 0 N
- Fa₅ = 0 N
- Fa₆ = 61 N

■ **Static Safety Factor**

$$f_s = \frac{P_{0a}}{F_{amax}} = \frac{P_{0a}}{F_{a2}} = 48.0$$

■ **Nominal Life**

- Average axial load

$$F_{am} = \sqrt[3]{\frac{1}{2 \cdot l_s} (F_{a1}^3 \times 1095 + F_{a2}^3 \times 52.5 + F_{a6}^3 \times 52.5)} = 26.2 \text{ N}$$

- Nominal life

$$L = \left(\frac{C_a}{f_w \cdot F_{am}} \right)^3 \times 10^6 = 1.41 \times 10^{13} \text{ rev}$$

f_w : Load factor (1.2)

* Convert the above nominal life into the service life in travel distance of the Ball Screw.

$$L_s = L \cdot l \times 10^{-6} = 2.82 \times 10^8 \text{ km}$$

[Result]

The table below shows the result of the examination.

KR5520A	LM guide unit	Ball screw unit	Bearing unit (Fixed side)
Static safety factor	33.9	111.9	48.0
Buckling load(N)	—	11000	—
Permissible tensile compressive load(N)	—	35300	—
Dangerous speed(min ⁻¹)	—	1560	—
DN Value	—	31125	—
Nominal life(km)	3.25 × 10 ⁶	3.05 × 10 ⁷	2.82 × 10 ⁸
Maximum working rotation speed(min ⁻¹)	—	1500	—

Note1) From the static safety coefficient and other values above, it is judged that the assumed model can be used.

Note2) Of the rated lives of the three components, the shortest value (of LM Guide unit) is considered the nominal life of the assumed model KR 5520A.

[Condition (Vertical Installation)]

Assumed model number : KR 5520A
 LM Guide Unit (C = 38100 N, C₀ = 61900N)
 Ball Screw Unit (C_a = 3620 N, C_{0a} = 9290 N)
 Bearing Unit(Fixed Side) (C_a = 7600 N, P_{0a} = 3990 N)
 Mass : m = 30 kg
 Speed : v = 500mm/s
 Acceleration : α = 2.4 m/s²
 Stroke : l_s = 1200 mm
 Gravitational acceleration : g = 9.807 m/s²
 Velocity diagram see Fig.2

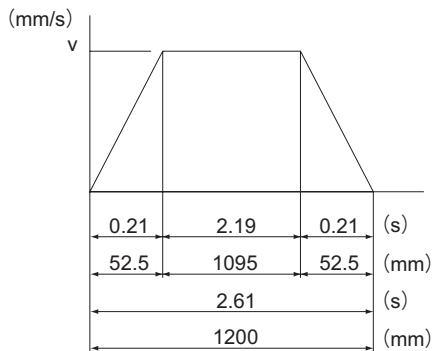
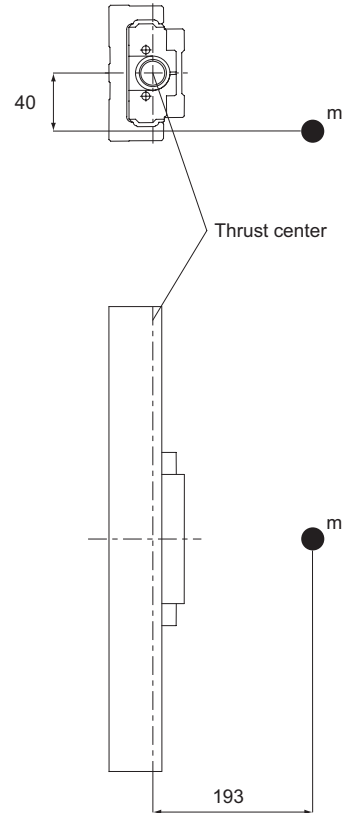

Fig.2 Velocity Diagram



[Consideration]

● Studying the LM Guide Unit

■ Load Applied to the Inner Block

* Assuming that a single inner block is used, convert applied moments M_A and M_B into applied load by multiplying them by the moment equivalent factor (K_A = K_B = 8.63 × 10⁻²).

● During uniform motion:

$$P_1 = K_A \cdot mg \times 193 = 4900 \text{ N}$$

$$P_{1T} = K_B \cdot mg \times 40 = 1016 \text{ N}$$

● During acceleration:

$$P_{1a} = P_1 + K_A \cdot m\alpha \times 193 = 6100 \text{ N}$$

$$P_{1aT} = P_{1T} + K_B \cdot m\alpha \times 40 = 1264 \text{ N}$$

● During deceleration:

$$P_{1d} = P_1 - K_A \cdot m\alpha \times 193 = 3701 \text{ N}$$

$$P_{1dT} = P_{1T} - K_B \cdot m\alpha \times 40 = 767 \text{ N}$$

■ Combined Radial And Thrust Load

● During uniform motion:

$$P_{1E} = P_1 + P_{1T} = 5916 \text{ N}$$

● During acceleration:

$$P_{1aE} = P_{1a} + P_{1aT} = 7364 \text{ N}$$

● During deceleration:

$$P_{1dE} = P_{1d} + P_{1dT} = 4468 \text{ N}$$

■ Static Safety Factor

$$f_s = \frac{C_0}{P_{\max}} = \frac{C_0}{P_{1aE}} = 8.4$$

■Nominal Life

- Average load

$$P_m = \sqrt[3]{\frac{1}{\ell_s} (P_{1E}^3 \times 1095 + P_{1aE}^3 \times 52.5 + P_{1dE}^3 \times 52.5)} = 5947 \text{ N}$$

- Nominal life

$$L = \left(\frac{C}{f_w \cdot P_m} \right)^3 \times 50 = 7.61 \times 10^3 \text{ km}$$

f_w : Load factor (1.2)

● Studying the Ball Screw Unit

■Axial Load

- During upward uniform motion:

$$F_{a1} = mg + f = 304 \text{ N}$$

f : Sliding resistance per block (10.0 N)

- During upward acceleration:

$$F_{a2} = F_{a1} + m\alpha = 376 \text{ N}$$

- During upward deceleration:

$$F_{a3} = F_{a1} - m\alpha = 232 \text{ N}$$

- During downward uniform motion:

$$F_{a4} = mg - f = 284 \text{ N}$$

- During downward acceleration:

$$F_{a5} = F_{a4} - m\alpha = 212 \text{ N}$$

- During downward deceleration:

$$F_{a6} = F_{a4} + m\alpha = 356 \text{ N}$$

■Static Safety Factor

$$f_s = \frac{C_{0a}}{F_{\max}} = \frac{C_{0a}}{F_{a2}} = 24.7$$

■Buckling Load

Same as Horizontal Installation

■Permissible Tensile Compressive Load

Same as Horizontal Installation

■Dangerous Speed

Same as Horizontal Installation

■DN Value

Same as Horizontal Installation

■Nominal Life

- Average axial load

$$F_m = \sqrt[3]{\frac{1}{2 \cdot \ell_s} (F_{a1}^3 \times 1095 + F_{a2}^3 \times 52.5 + F_{a3}^3 \times 52.5 + F_{a4}^3 \times 1095 + F_{a5}^3 \times 52.5 + F_{a6}^3 \times 52.5)} = 296 \text{ N}$$

- Nominal life

$$L = \left(\frac{C_a}{f_w \cdot F_m} \right)^3 \times \ell = 2.11 \times 10^4 \text{ km}$$

f_w : Load factor (1.2) ℓ : Ball Screw lead (20mm)

● **Bearing Unit (Fixed Side)**

■ **Axial Load (Same as the Ball Screw Unit)**

- Fa₁ = 304 N
- Fa₂ = 376 N
- Fa₃ = 232 N
- Fa₄ = 284 N
- Fa₅ = 212 N
- Fa₆ = 356 N

■ **Static Safety Factor**

$$f_s = \frac{P_{0a}}{F_{max}} = \frac{P_{0a}}{F_{a2}} = 10.6$$

■ **Nominal Life**

- Average axial load

$$F_m = \sqrt[3]{\frac{1}{2 \cdot \ell_s} (F_{a1}^3 \times 1095 + F_{a2}^3 \times 52.5 + F_{a3}^3 \times 52.5 + F_{a4}^3 \times 1095 + F_{a5}^3 \times 52.5 + F_{a6}^3 \times 52.5)} = 296 \text{ N}$$

- Nominal life

$$L = \left(\frac{C_a}{f_w \cdot F_m} \right)^3 \times 10^6 = 9.80 \times 10^9 \text{ rev}$$

f_w : Load factor (1.2)

* Convert the above nominal life into the service life in travel distance of the Ball Screw.

$$L_s = L \cdot \ell \times 10^{-6} = 1.95 \times 10^5 \text{ km}$$

[Result]

The table below shows the result of the examination.

KR5520A	LM guide unit	Ball screw unit	Bearing unit (Fixed side)
Static safety factor	8.4	24.7	10.6
Buckling load(N)	—	11000	—
Permissible tensile compressive load(N)	—	35300	—
Dangerous speed(min ⁻¹)	—	1560	—
DN Value	—	31125	—
Nominal life(km)	7.61 × 10 ³	2.11 × 10 ⁴	1.95 × 10 ⁵
Maximum working rotation speed(min ⁻¹)	—	1500	—

Note1) From the static safety coefficient and other values above, it is judged that the assumed model can be used.

Note2) Of the rated lives of the three components, the shortest value (of LM Guide unit) is considered the nominal life of the assumed model KR 5520A.

Accuracy Standards

The accuracy standard of model KR is defined in positioning repeatability, positioning accuracy, running parallelism (vertical direction) and backlash.

[Positioning Repeatability]

After repeating positioning to a given point in the same direction seven times, measure the halting point and obtain the value of half the maximum difference. Perform this measurement in the center and both ends of the travel distance; use the maximum difference as the measurement value and express the value of half the maximum difference with a “±” sign prefixed to the value.

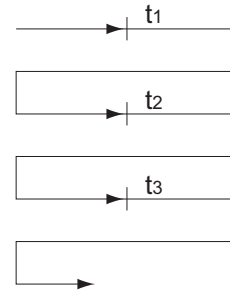

Fig.3 Positioning Repeatability

[Positioning Accuracy]

Using the maximum stroke as the reference length, express the maximum error between the actual distance traveled from the reference point and the command value in an absolute value as positioning accuracy.

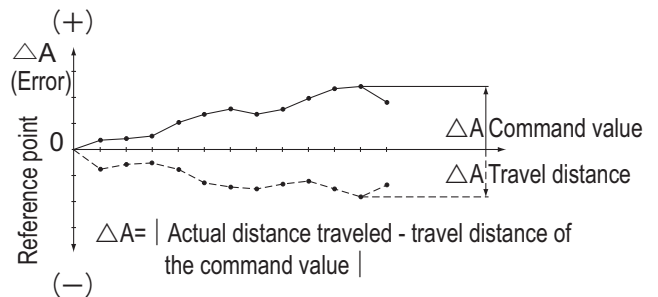

Fig.4 Positioning Accuracy

[Running of Parallelism (Vertical direction)]

Place a straightedge on the surface table where model KR is mounted, measure almost throughout the travel distance of the inner block using a test indicator. Use the maximum difference among the readings within the travel distance as the running parallelism measurement.

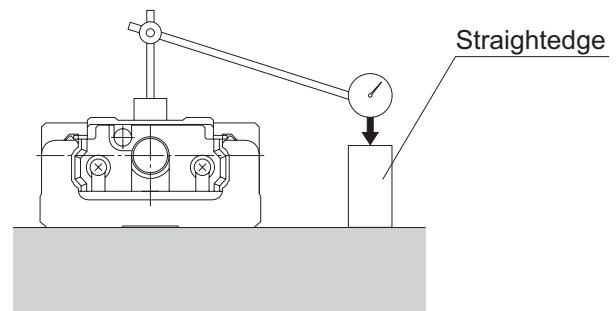

Fig.5 Running of Parallelism

[Backlash]

Feed and slightly move the inner block and read the measurement on the test indicator as the reference value. Subsequently, apply a load to the inner block from the same direction (table feed direction), and then release the inner block from the load. Use the difference between the reference value and the return as the backlash measurement.

Perform this measurement in the center and near both ends, and use the maximum value as the measurement value.

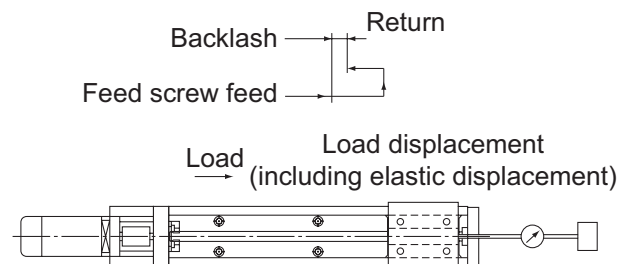

Fig.6 Backlash

The accuracies of model KR are classified into normal grade (no symbol), high accuracy grade (H) and precision grade (P). Tables below show standards for all the accuracies.

Table10 Normal Grade (No Symbol)

Unit: mm

Model No.	Stroke*	Outer rail length	Positioning Repeatability	Positioning Accuracy	Running Parallelism (Vertical Direction)	Backlash	Starting torque (N-cm)
KR20	30	100	±0.01	No standard defined	No standard defined	0.02	0.5
	80	150					
	130	200					
KR26	60	150	±0.01	No standard defined	No standard defined	0.02	1.5
	110	200					
	160	250					
	210	300					
KR30H	50	150	±0.01	No standard defined	No standard defined	0.02	7
	100	200					
	200	300					
	300	400					
	400	500					
	500	600					
KR33	50	150	±0.01	No standard defined	No standard defined	0.02	7
	100	200					
	200	300					
	300	400					
	400	500					
	500	600					
	600	700					
KR45H	200	340	±0.01	No standard defined	No standard defined	0.02	10
	300	440					
	400	540					
	500	640					
	600	740					
	700	840					
	800	940					
KR46	190	340	±0.01	No standard defined	No standard defined	0.02	10
	290	440					
	390	540					
	490	640					
	590	740					
	690	840					
	790	940					
KR55	800	980	±0.01	No standard defined	No standard defined	0.05	12
	900	1080					
	1000	1180					
	1100	1280					
	1200	1380					
KR65	790	980	±0.01	No standard defined	No standard defined	0.05	12
	990	1180					
	1190	1380					
	1490	1680	±0.012				15

*Indicates a stroke when one long-type inner block is incorporated.

Note1) The evaluation method complies with THK standards.

Note2) Measurements are taken while using a motor provided by THK. For motor-wrap configuration, these values may not apply.

Note3) The starting torque represents the value when THK AFB-LF Grease is used.

However, that of models KR20 and KR26 represents the value when THK AFA Grease is used, and that of KR15 represents the value when THK AFF Grease is used.

Note4) If highly viscous grease such as vacuum grease and clean room grease is used, the actual starting torque may exceed the corresponding value in the table. Use much care in selecting a motor.

Note5) Contact THK for information on the accuracy for standard or longer stroke.

Note6) Model KR15 is available in high accuracy grade (H) and precision grade (P) only.

Table11 High Accuracy Grade (H)

Unit: mm

Model No.	Stroke*	Outer rail length	Positioning accuracy repeatability	Positioning Accuracy	Running of Parallelism (Vertical direction)	Backlash	Starting torque (N-cm)
KR15	25	75	±0.004	0.04	0.02	0.01	0.4
	50	100					
	75	125					
	100	150					
	125	175					
	150	200					
KR20	30	100	±0.005	0.06	0.025	0.01	0.5
	80	150					
	130	200					
KR26	60	150	±0.005	0.06	0.025	0.01	1.5
	110	200					
	160	250					
	210	300					
KR30H	50	150	±0.005	0.06	0.025	0.02	7
	100	200					
	200	300		0.10	0.035		
	300	400					
	400	500					
	500	600					
KR33	50	150	±0.005	0.06	0.025	0.02	7
	100	200					
	200	300		0.10	0.035		
	300	400					
	400	500					
	500	600					
	600	700					
KR45H	200	340	±0.005	0.10	0.035	0.02	10
	300	440					
	400	540		0.12	0.04		
	500	640					
	600	740					
	700	840					
	800	940					
KR46	190	340	±0.005	0.10	0.035	0.02	10
	290	440					
	390	540		0.12	0.04		
	490	640					
	590	740					
	690	840					
790	940						
KR55	800	980	±0.005	0.18	0.05	0.05	12
	900	1080					
	1000	1180		0.25			
	1100	1280					
	1200	1380					
KR65	790	980	±0.008	0.18	0.05	0.05	12
	990	1180					
	1190	1380		0.28	0.055		
	1490	1680					15

Table12 Precision Grade (P)

Unit: mm

Model No.	Stroke*	Outer rail length	Positioning accuracy repeatability	Positioning Accuracy	Running of Parallelism (Vertical direction)	Backlash	Starting torque (N-cm)
KR15	25	75	±0.003	0.02	0.01	0.002	0.8
	50	100					
	75	125					
	100	150					
	125	175					
	150	200					
KR20	30	100	±0.003	0.02	0.01	0.003	1.2
	80	150					
	130	200					
KR26	60	150	±0.003	0.02	0.01	0.003	4
	110	200					
	160	250					
	210	300					
KR30H	50	150	±0.003	0.02	0.01	0.003	15
	100	200					
	200	300		0.025	0.015		
	300	400					
	400	500					
	500	600					
KR33	50	150	±0.003	0.02	0.01	0.003	15
	100	200					
	200	300		0.025	0.015		
	300	400					
	400	500					
	500	600					
	600	700					
KR45H	200	340	±0.003	0.025	0.015	0.003	15
	300	440					
	400	540		0.03	0.02		
	500	640					
	600	740					
KR46	190	340	±0.003	0.025	0.015	0.003	15
	290	440					
	390	540		0.03	0.02		
	490	640					
	590	740					
	690	840	±0.005	0.035	0.025		
	790	940					
KR55	800	980	±0.005	0.035	0.025	0.003	17
	900	1080					
	1000	1180		0.04	0.03		20
KR65	790	980	±0.005	0.035	0.025	0.005	20
	990	1180					
	1190	1380		0.04	0.03		22

*Indicates a stroke when one long-type inner block is incorporated.

Note1) The evaluation method complies with THK standards.

Note2) Measurements are taken while using a motor provided by THK. For motor-wrap configuration, these values may not apply.

Note3) The starting torque represents the value when THK AFB-LF Grease is used.

However, that of models KR20 and KR26 represents the value when THK AFA Grease is used, and that of KR15 represents the value when THK AFF Grease is used.

Note4) If highly viscous grease such as vacuum grease and clean room grease is used, the actual starting torque may exceed the corresponding value in the table. Use much care in selecting a motor.

Note5) Contact THK for information on the accuracy for standard or longer stroke.

Model Number Coding

Model No.	Ball Screw Lead	Inner block type	Stroke	Accuracy
KR33	10	A	0200	P

①

②

③

④

⑤

KR15
KR20
KR26
KR30H
KR33
KR45H
KR46
KR55
KR65

01 : 1mm
02 : 2mm
06 : 6mm
10 : 10mm
20 : 20mm
25 : 25 mm (KR65 only)

A
B
C
D

0025 : 25mm
0050 : 50mm
∞
1490 : 1490mm

No symbol: normal grade
H : High accuracy grade
P : Precision Grade

If "2" (with Bellows) was selected for the cover ⑦, specify a stroke incorporating the bellows(→page 60).

The available ball screw leads differ depending on the model.

KR15 : "01", "02"
 KR20 : "01", "06"
 KR26 : "02", "06"
 KR30H : "06", "10"
 KR33 : "06", "10"
 KR45H : "10", "20"
 KR46 : "10", "20"
 KR55 : "20"
 KR65 : "25"

	With/without a motor		Cover	Sensor	Housing A/ Intermediate Flange
	0	-	1	B	AQ
	⑥		⑦	⑧	⑨
	0: direct-coupled (without a motor) 1: direct-coupled (with a motor, specified by the customer)		0: without a cover 1: with a cover 2: with a bellows	0: none 1 2 6 7 B E H L J M	10 20 30 40 50 60 A0 A5 A6 AM AN AP AQ AR AS AT AU AV AY AZ
	<p>If "0" is selected, a coupling is not attached. If a coupling is required, please indicate so.</p> <p>"1" means that a motor specified by the customer is mounted.</p> <p>For item ⑨, select a housing A/intermediate flange that matches the specified motor.</p>				
	<p>Several motors by different manufacturers can be mounted. Contact THK for details.</p>				

A type with a wrap-around housing A and a motor wrap-around type, which are not contained in the catalog, are also available. Contact THK for details.

Model KR15 Standard Type

Model KR15□□A (with a Single Long Nut Block)

Model KR15□□B (with Two Long Nut Blocks)

For model number coding, see page31.

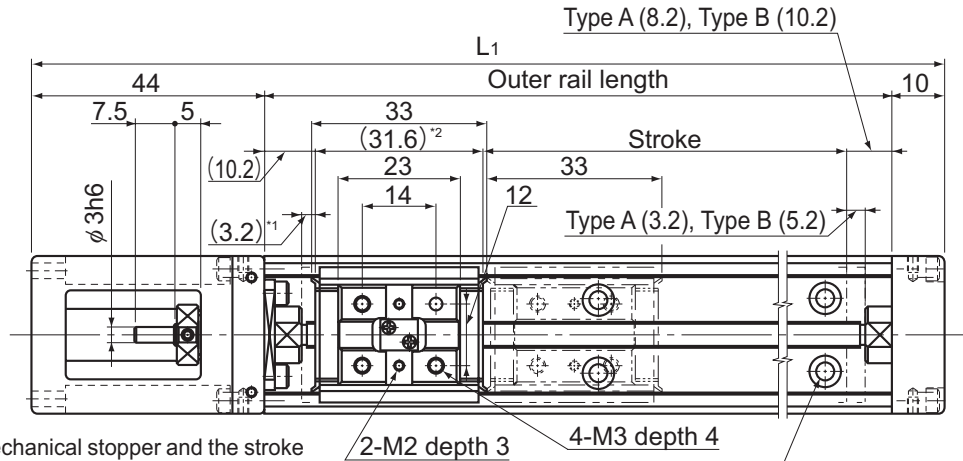

*1 Distance between the mechanical stopper and the stroke starting position.

*2 Indicates the inner block length when calculating the available stroke range. The length in model KR-B (with two long-type inner blocks) is 64.6 mm.

2×n-3.4 through hole, $\phi 6$ counter bore depth 2
(Fixed using M3 hexagon socket button bolt)

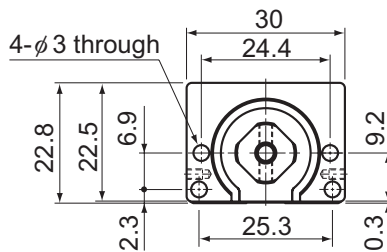
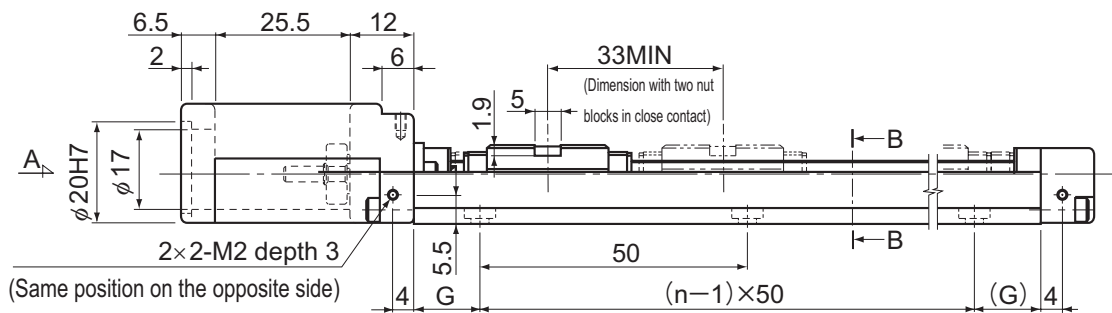

A arrow view

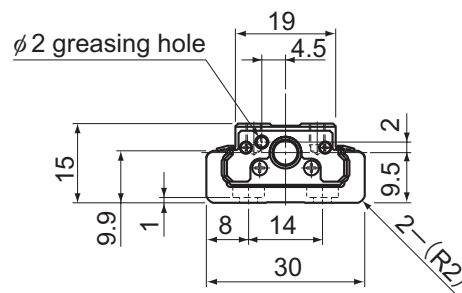

B-B cross section

Stroke (mm) (stroke between mechanical stoppers)		Outer rail length (mm)	Overall length L_1 (mm)	G (mm)	n	Overall main unit mass (kg)	
Type A	Type B*					Type A	Type B
25(31.4)	—	75	129	12.5	2	0.19	—
50(56.4)	—	100	154	25	2	0.22	—
75(81.4)	40(48.4)	125	179	12.5	3	0.25	0.292
100(106.4)	65(73.4)	150	204	25	3	0.28	0.322
125(131.4)	90(98.4)	175	229	12.5	4	0.31	0.352
150(156.4)	115(123.4)	200	254	25	4	0.34	0.382

*Indicates a value when two inner blocks are in close contact with each other.

Model KR15 (with a Cover)

Model KR15□□A (with a Single Long Nut Block)

Model KR15□□B (with Two Long Nut Blocks)

For model number coding, see page31.

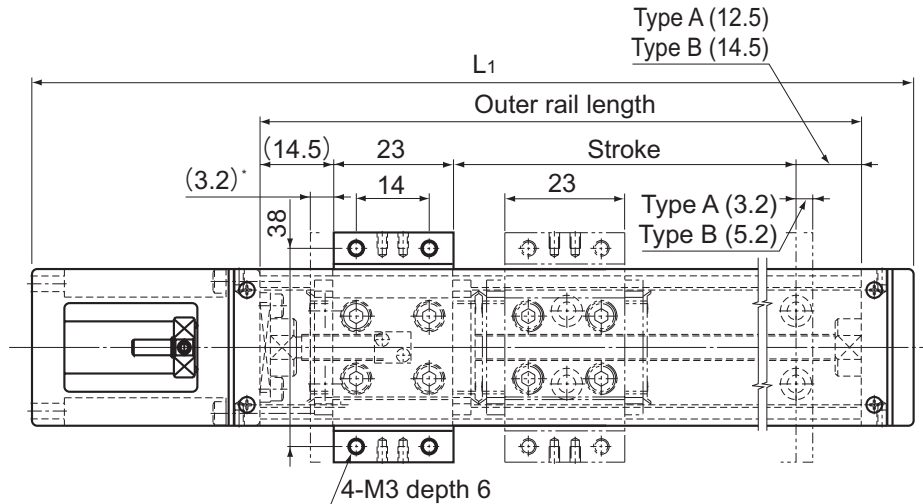

* Distance between the mechanical stopper and the stroke starting position.

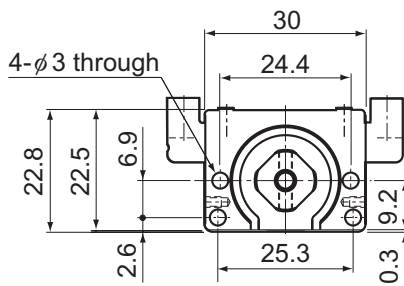
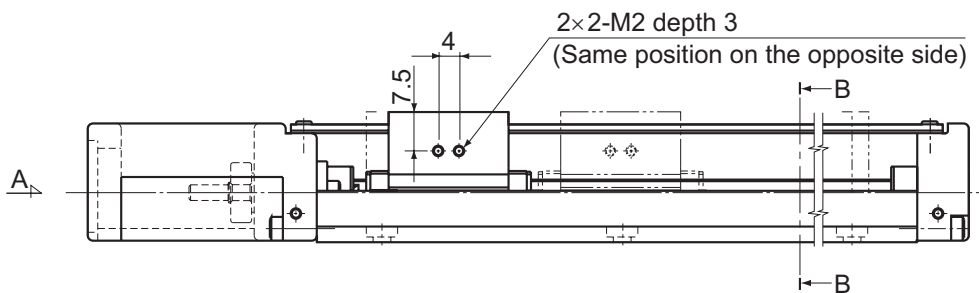

A arrow view

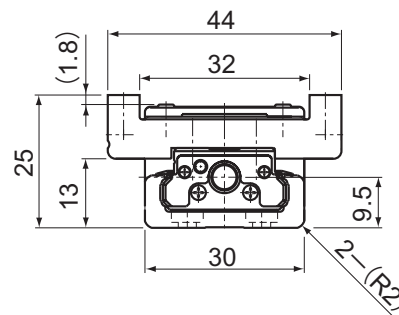

B-B cross section

Stroke (mm) (stroke between mechanical stoppers)		Outer rail length (mm)	Overall length L ₁ (mm)	Overall main unit mass (kg)	
Type A	Type B*			Type A	Type B
25(31.4)	—	75	129	0.23	—
50(56.4)	—	100	154	0.26	—
75(81.4)	40(48.4)	125	179	0.3	0.364
100(106.4)	65(73.4)	150	204	0.33	0.394
125(131.4)	90(98.4)	175	229	0.36	0.424
150(156.4)	115(123.4)	200	254	0.4	0.464

*Indicates a value when two inner blocks are in close contact with each other.

Options⇒page60

Model KR20 Standard Type

Model KR20□□A (with a Single Long Nut Block)

Model KR20□□B (with Two Long Nut Blocks)

For model number coding, see page31.

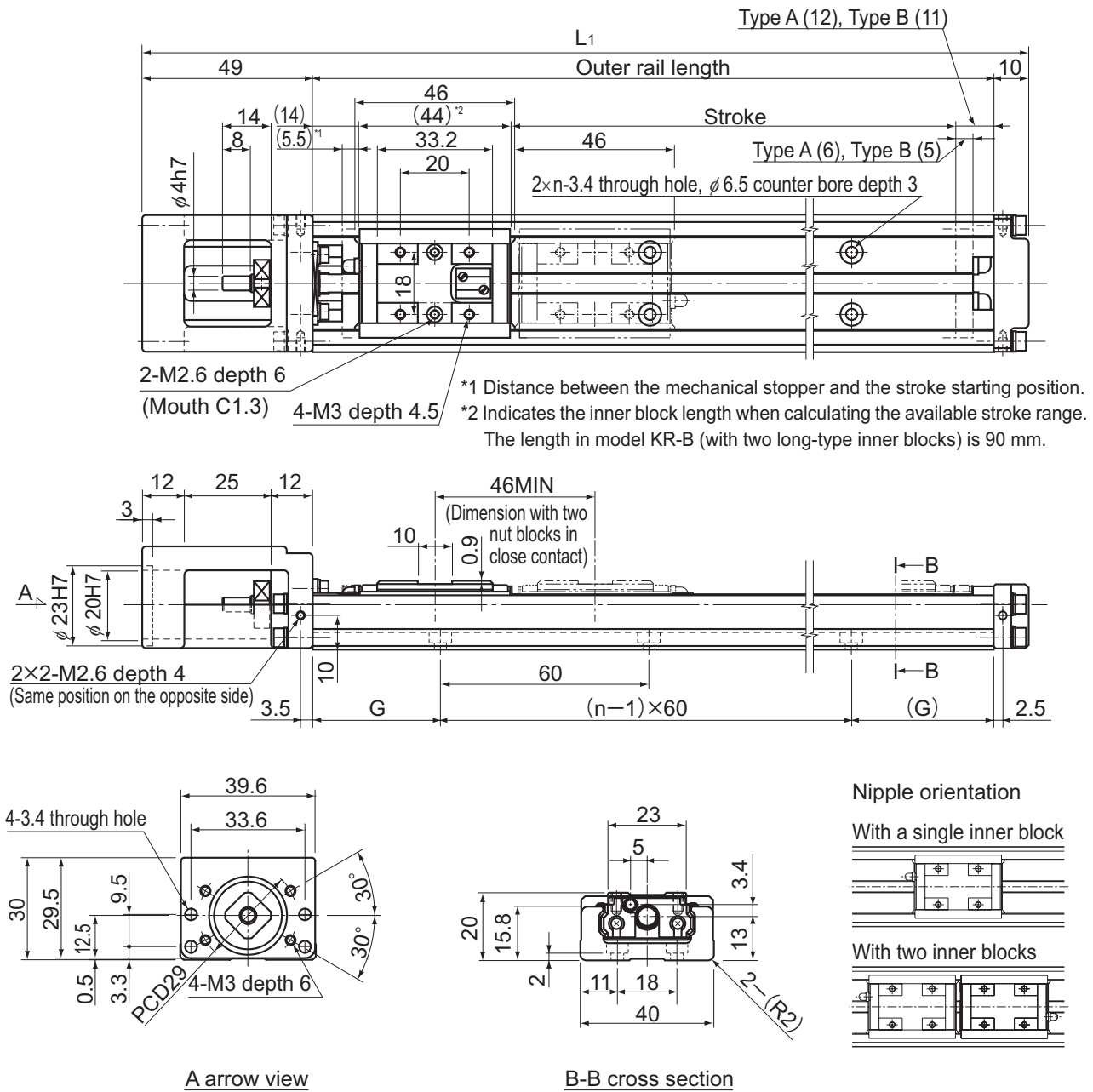

Stroke (mm) (stroke between mechanical stoppers)		Outer rail length (mm)	Overall length L_1 (mm)	G (mm)	n	Overall main unit mass (kg)	
Type A	Type B*					Type A	Type B
30(41.5)	—	100	159	20	2	0.45	—
80(91.5)	35(45.5)	150	209	15	3	0.58	0.655
130(141.5)	85(95.5)	200	259	40	3	0.72	0.795

*Indicates a value when two inner blocks are in close contact with each other.

Model KR20 (with a Cover)

Model KR20□□A (with a Single Long Nut Block)

Model KR20□□B (with Two Long Nut Blocks)

For model number coding, see page31.

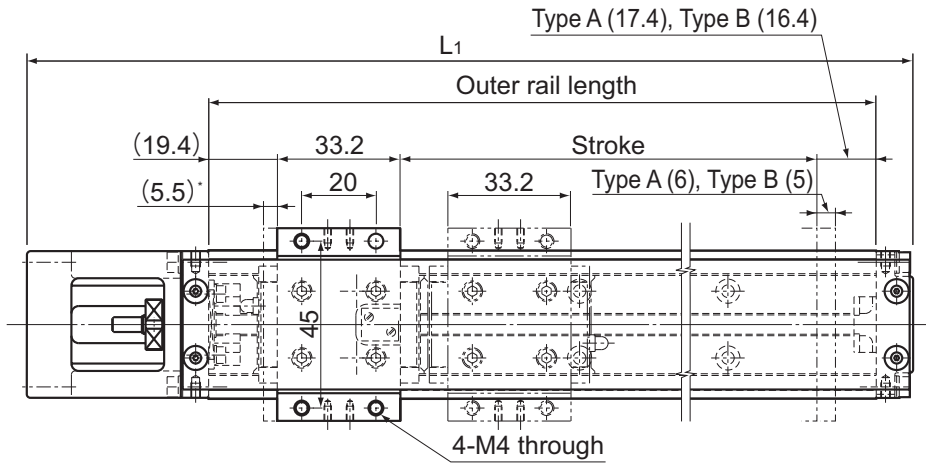

* Distance between the mechanical stopper and the stroke starting position.

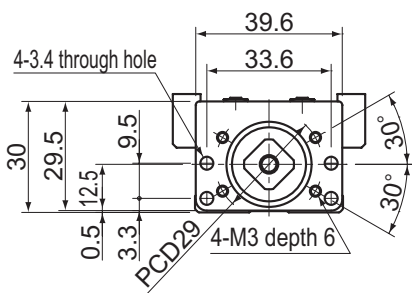
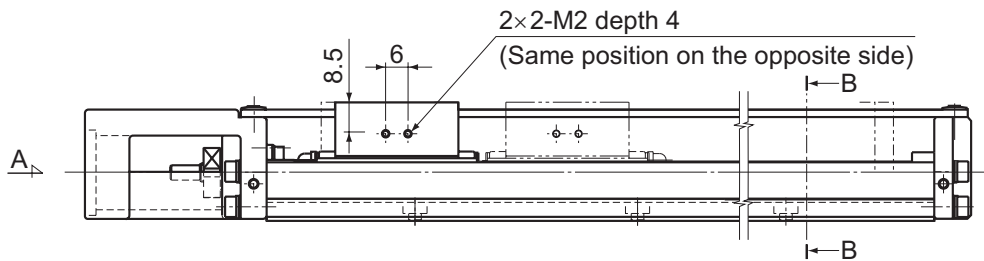

A arrow view

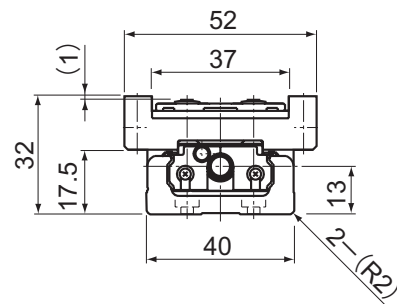

B-B cross section

Stroke (mm) (stroke between mechanical stoppers)		Outer rail length (mm)	Overall length L ₁ (mm)	Overall main unit mass (kg)	
Type A	Type B*			Type A	Type B
30(41.5)	—	100	159	0.51	—
80(91.5)	35(45.5)	150	209	0.66	0.78
130(141.5)	85(95.5)	200	259	0.8	0.92

*Indicates a value when two inner blocks are in close contact with each other.

Model KR26 Standard Type

Model KR26□□A (with a Single Long Nut Block)

Model KR26□□B (with Two Long Nut Blocks)

For model number coding, see page31.

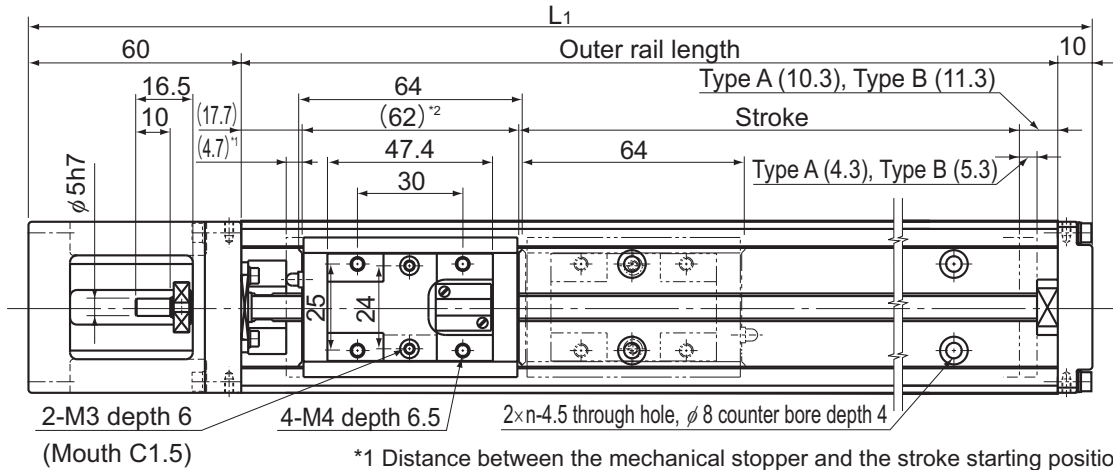

*1 Distance between the mechanical stopper and the stroke starting position.
 *2 Indicates the inner block length when calculating the available stroke range.
 The length in model KR-B (with two long-type inner blocks) is 126 mm.

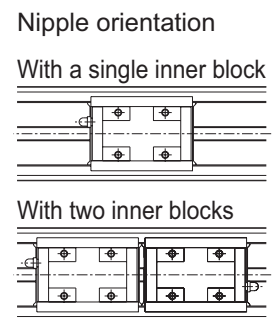
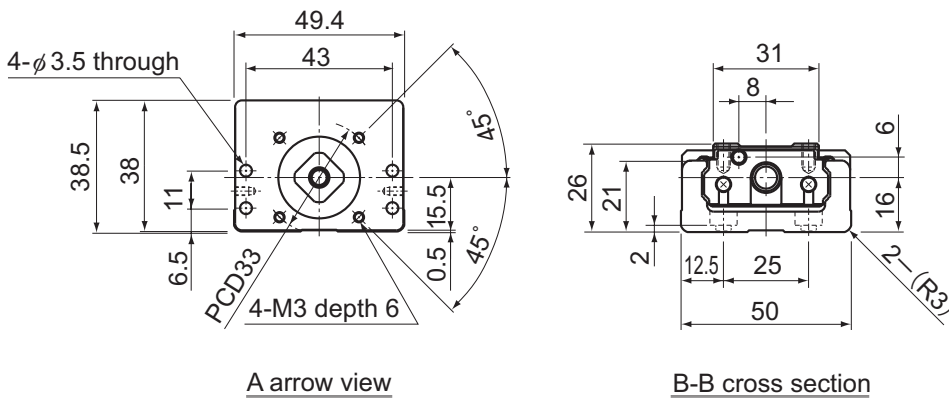
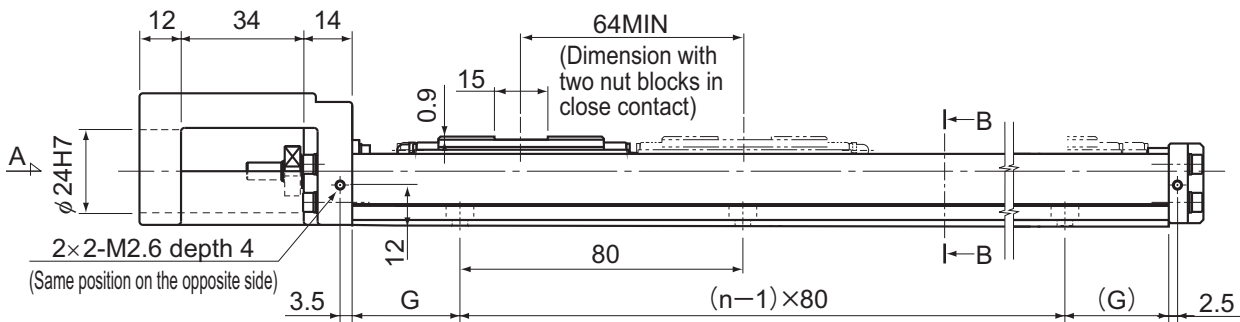

Stroke (mm) (stroke between mechanical stoppers)		Outer rail length (mm)	Overall length L_1 (mm)	G (mm)	n	Overall main unit mass (kg)	
Type A	Type B*					Type A	Type B
60(69)	—	150	220	35	2	0.99	—
110(119)	45(55)	200	270	20	3	1.2	1.38
160(169)	95(105)	250	320	45	3	1.41	1.59
210(219)	145(155)	300	370	30	4	1.62	1.8

*Indicates a value when two inner blocks are in close contact with each other.

Model KR26 (with a Cover)

Model KR26□□A (with a Single Long Nut Block)

Model KR26□□B (with Two Long Nut Blocks)

For model number coding, see page31.

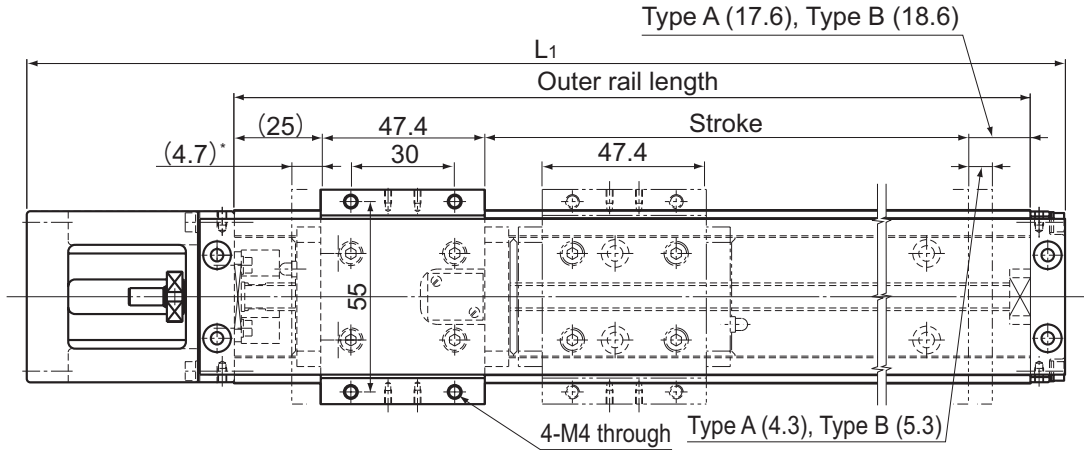

* Distance between the mechanical stopper and the stroke starting position.

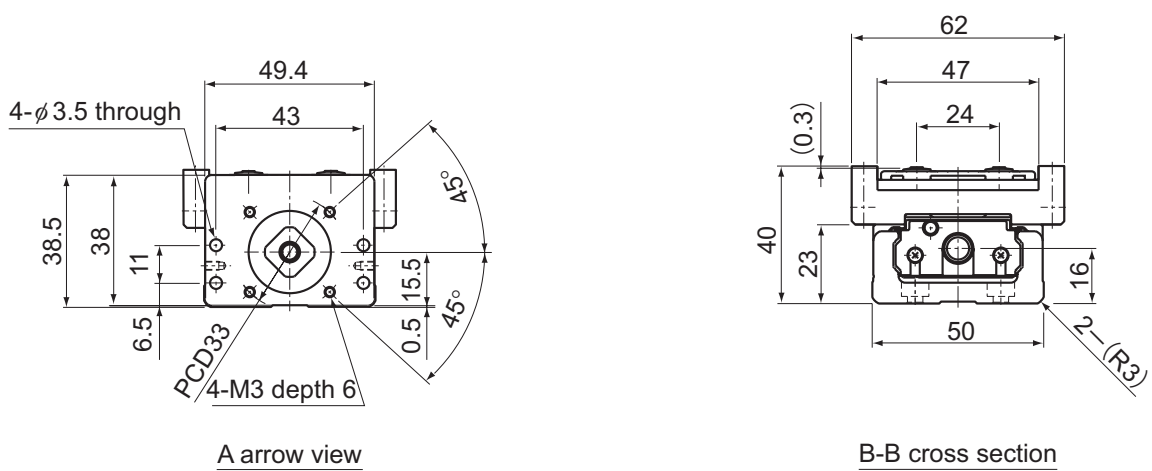
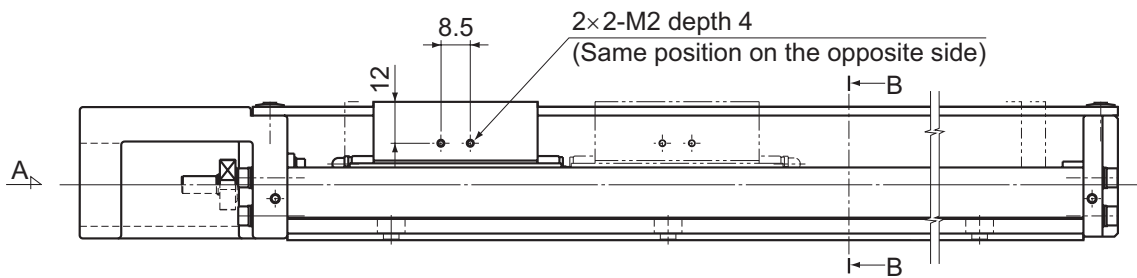

Stroke (mm) (stroke between mechanical stoppers)		Outer rail length (mm)	Overall length L ₁ (mm)	Overall main unit mass (kg)	
Type A	Type B*			Type A	Type B
60(69)	—	150	220	1.12	—
110(119)	45(55)	200	270	1.34	1.605
160(169)	95(105)	250	320	1.56	1.825
210(219)	145(155)	300	370	1.78	2.045

*Indicates a value when two inner blocks are in close contact with each other.

Model KR30H Standard Type

Model KR30H□□A (with a Single Long Nut Block)

Model KR30H□□B (with Two Long Nut Blocks)

For model number coding, see page31.

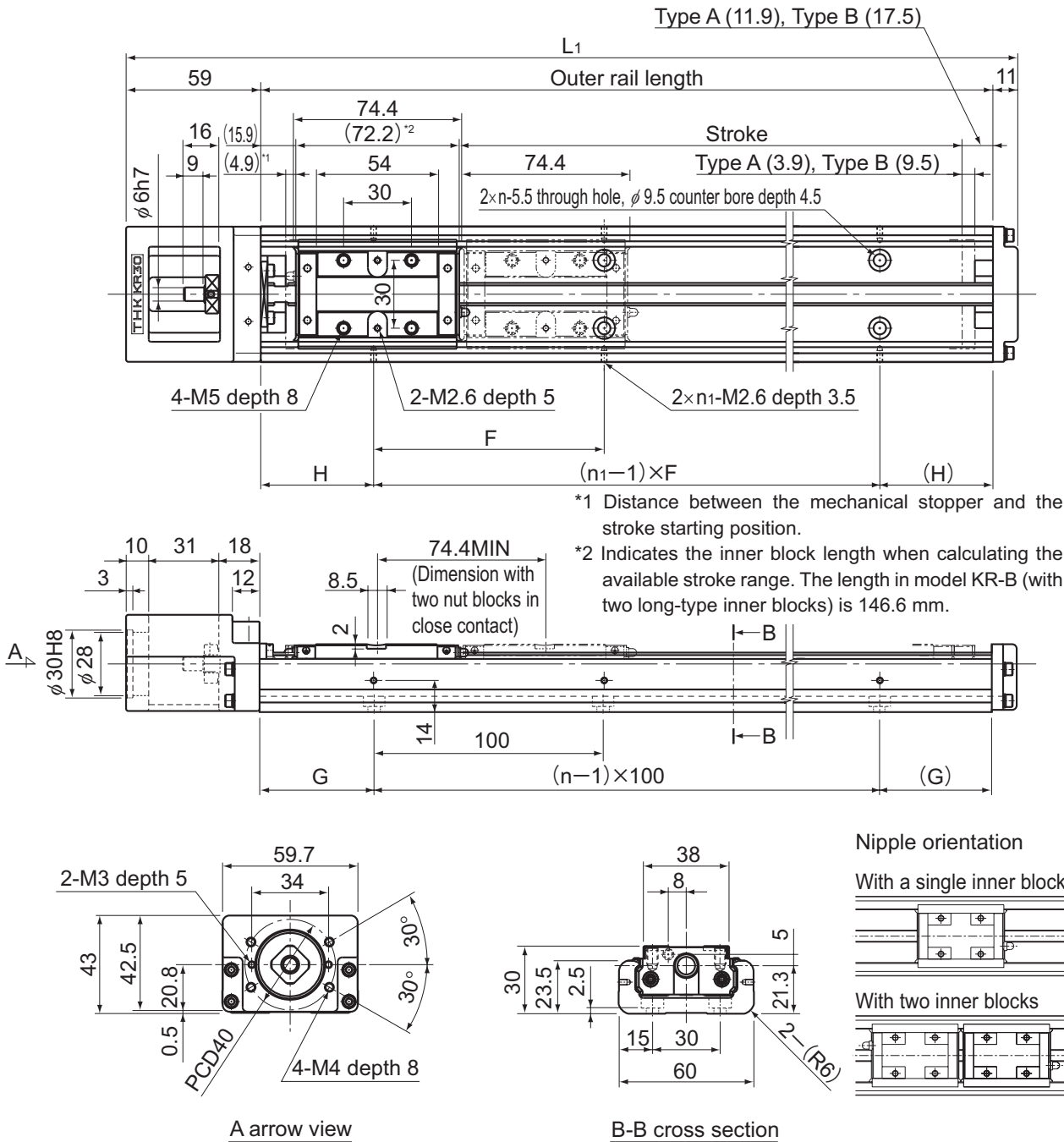

Stroke (mm) (stroke between mechanical stoppers)		Outer rail length (mm)	Overall length L_1 (mm)	H (mm)	G (mm)	F (mm)	n	n ₁	Overall main unit mass (kg)	
Type A	Type B*								Type A	Type B
50(58.8)	—	150	220	25	25	100	2	2	1.4	—
100(108.8)	—	200	270	50	50	100	2	2	1.6	—
200(208.8)	120(134.4)	300	370	50	50	200	3	2	2.2	2.5
300(308.8)	220(234.4)	400	470	100	50	200	4	2	2.7	3
400(408.8)	320(334.4)	500	570	50	50	200	5	3	3.2	3.5
500(508.8)	420(434.4)	600	670	100	50	200	6	3	3.8	4.1

*Indicates a value when two inner blocks are in close contact with each other.

Model KR30H (with a Cover)

Model KR30H□□A (with a Single Long Nut Block)

Model KR30H□□B (with Two Long Nut Blocks)

For model number coding, see page31.

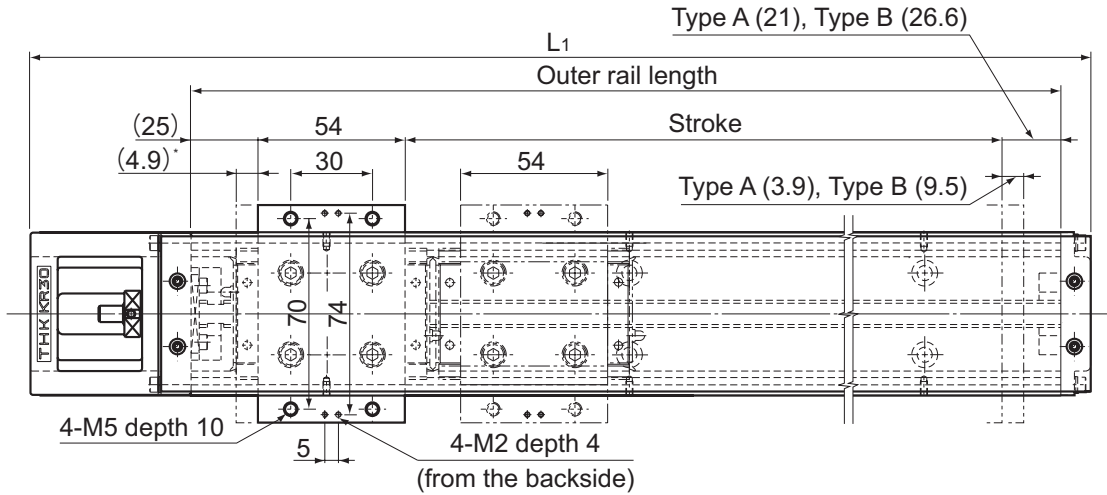

* Distance between the mechanical stopper and the stroke starting position.

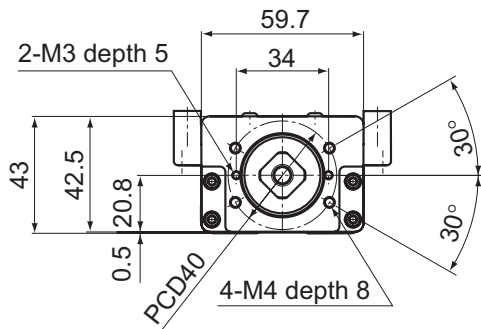
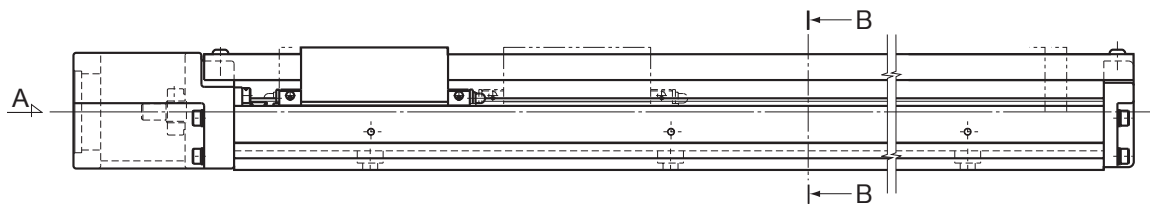

A arrow view

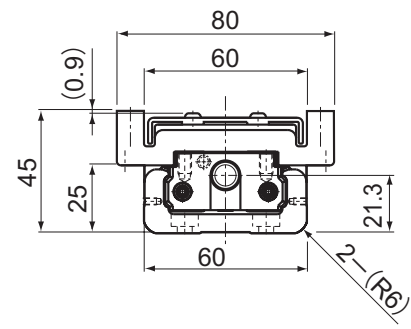

B-B cross section

Stroke (mm) (stroke between mechanical stoppers)		Outer rail length (mm)	Overall length L ₁ (mm)	Overall main unit mass (kg)	
Type A	Type B*			Type A	Type B
50(58.8)	—	150	220	1.6	—
100(108.8)	—	200	270	1.8	—
200(208.8)	120(134.4)	300	370	2.4	2.83
300(308.8)	220(234.4)	400	470	3	3.43
400(408.8)	320(334.4)	500	570	3.5	3.93
500(508.8)	420(434.4)	600	670	4.1	4.53

*Indicates a value when two inner blocks are in close contact with each other.

Model KR30H Standard Type

Model KR30H□□C (with a Single Short Nut Block)

Model KR30H□□D (with Two Short Nut Blocks)

For model number coding, see page31.

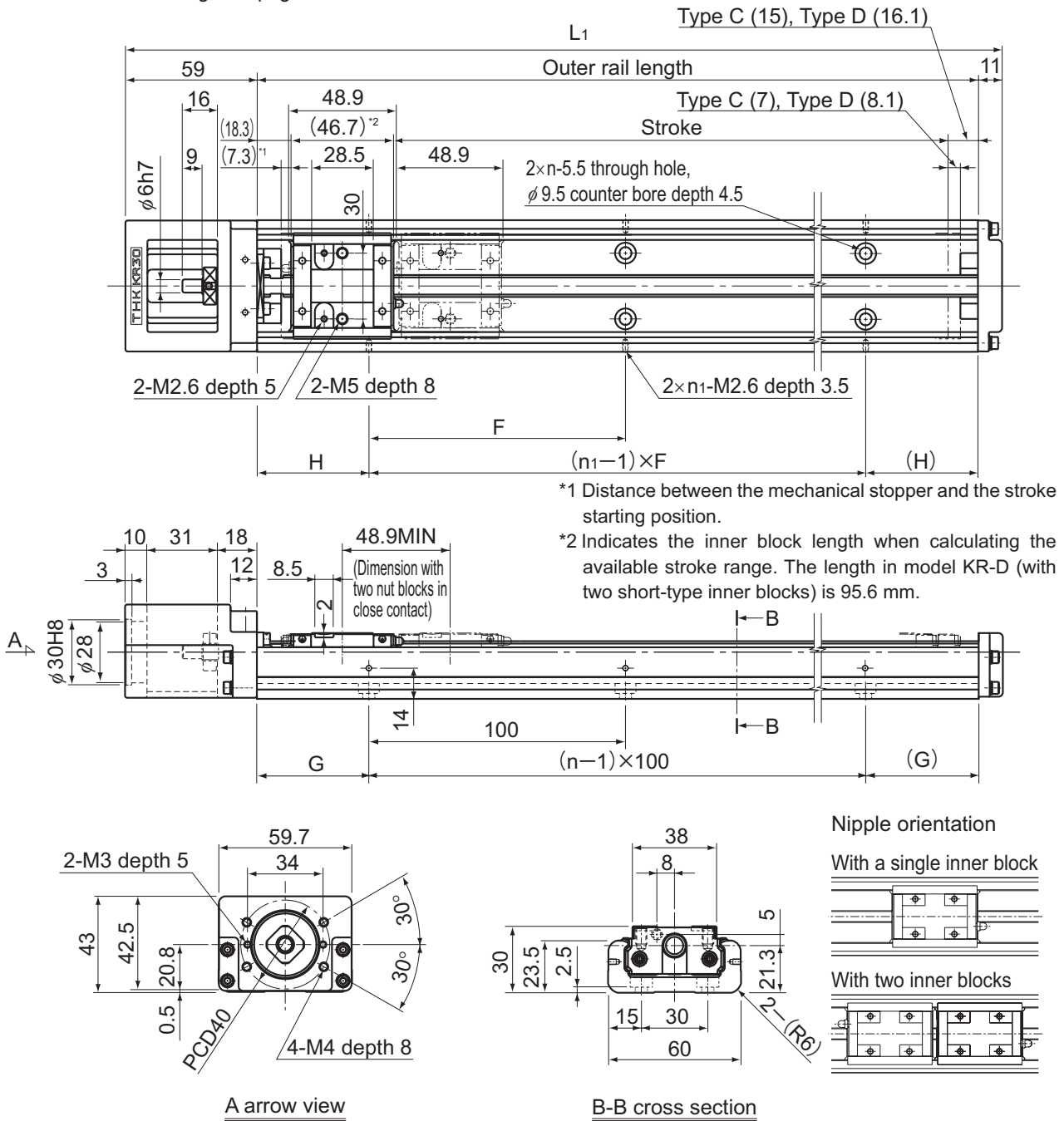

Stroke (mm) (stroke between mechanical stoppers)		Outer rail length (mm)	Overall length L_1 (mm)	H (mm)	G (mm)	F (mm)	n	n_1	Overall main unit mass (kg)	
Type C	Type D*								Type C	Type D
70(84.3)	20(35.4)	150	220	25	25	100	2	2	1.3	1.47
120(134.3)	70(85.4)	200	270	50	50	100	2	2	1.5	1.67
220(234.3)	170(185.4)	300	370	50	50	200	3	2	2.1	2.27
320(334.3)	270(285.4)	400	470	100	50	200	4	2	2.6	2.77
420(434.3)	370(385.4)	500	570	50	50	200	5	3	3.1	3.27
520(534.3)	470(485.4)	600	670	100	50	200	6	3	3.7	3.87

*Indicates a value when two inner blocks are in close contact with each other.

Model KR30H (with a Cover)

Model KR30H□□C (with a Single Short Nut Block)

Model KR30H□□D (with Two Short Nut Blocks)

For model number coding, see page31.

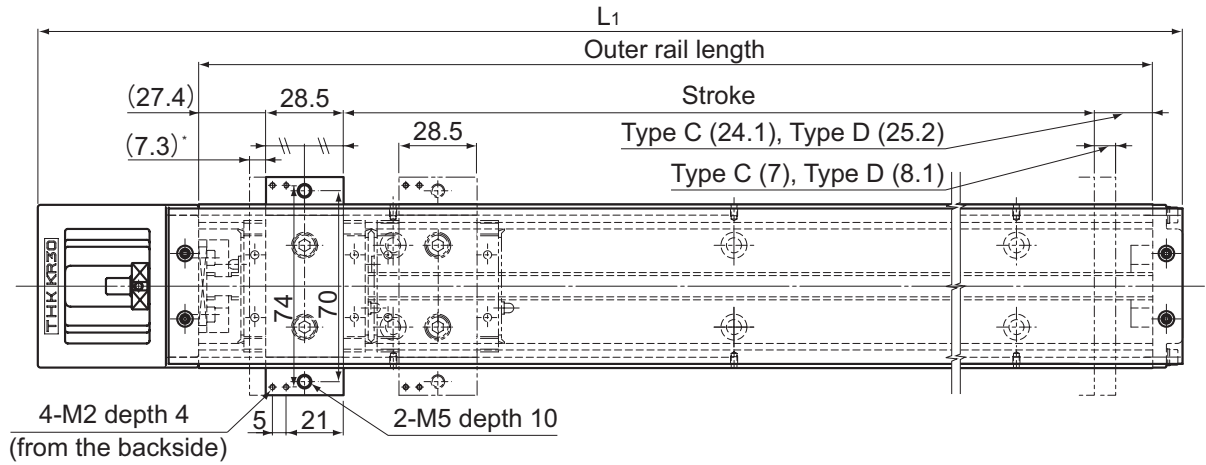

* Distance between the mechanical stopper and the stroke starting position.

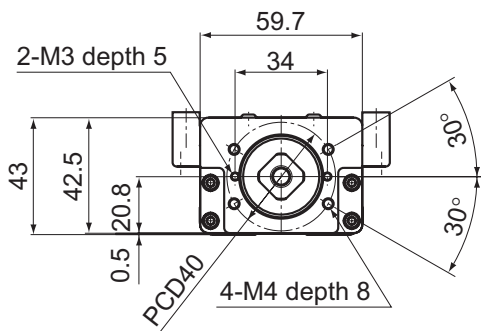
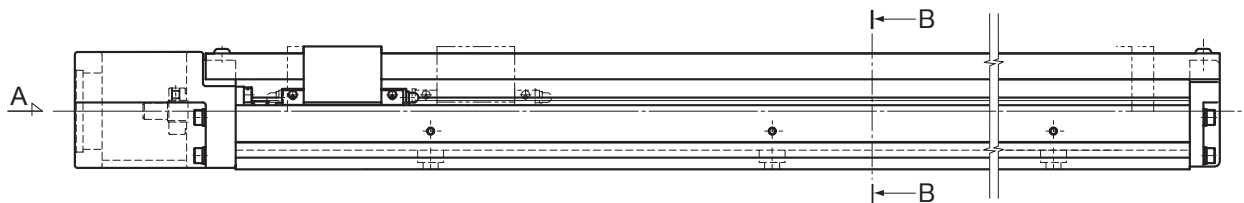

A arrow view

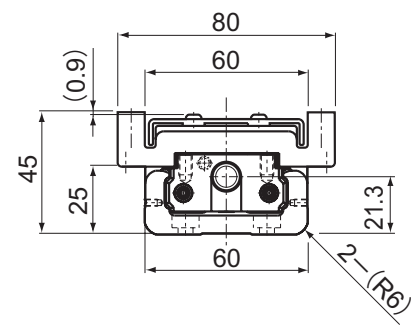

B-B cross section

Stroke (mm) (stroke between mechanical stoppers)		Outer rail length (mm)	Overall length L ₁ (mm)	Overall main unit mass (kg)	
Type C	Type D*			Type C	Type D
70(84.3)	20(35.4)	150	220	1.4	1.64
120(134.3)	70(85.4)	200	270	1.6	1.84
220(234.3)	170(185.4)	300	370	2.2	2.44
320(334.3)	270(285.4)	400	470	2.8	3.04
420(434.3)	370(385.4)	500	570	3.3	3.54
520(534.3)	470(485.4)	600	670	3.9	4.14

*Indicates a value when two inner blocks are in close contact with each other.

Model KR33 Standard Type

Model KR33□□A (with a Single Long Nut Block)

Model KR33□□B (with Two Long Nut Blocks)

For model number coding, see page31.

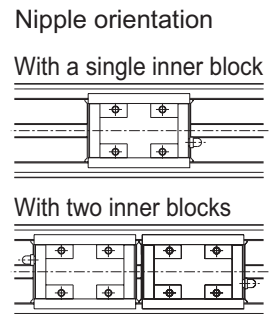
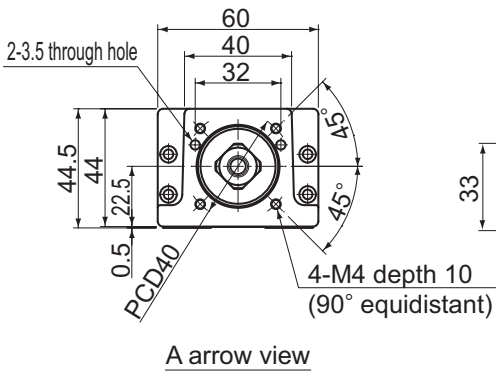
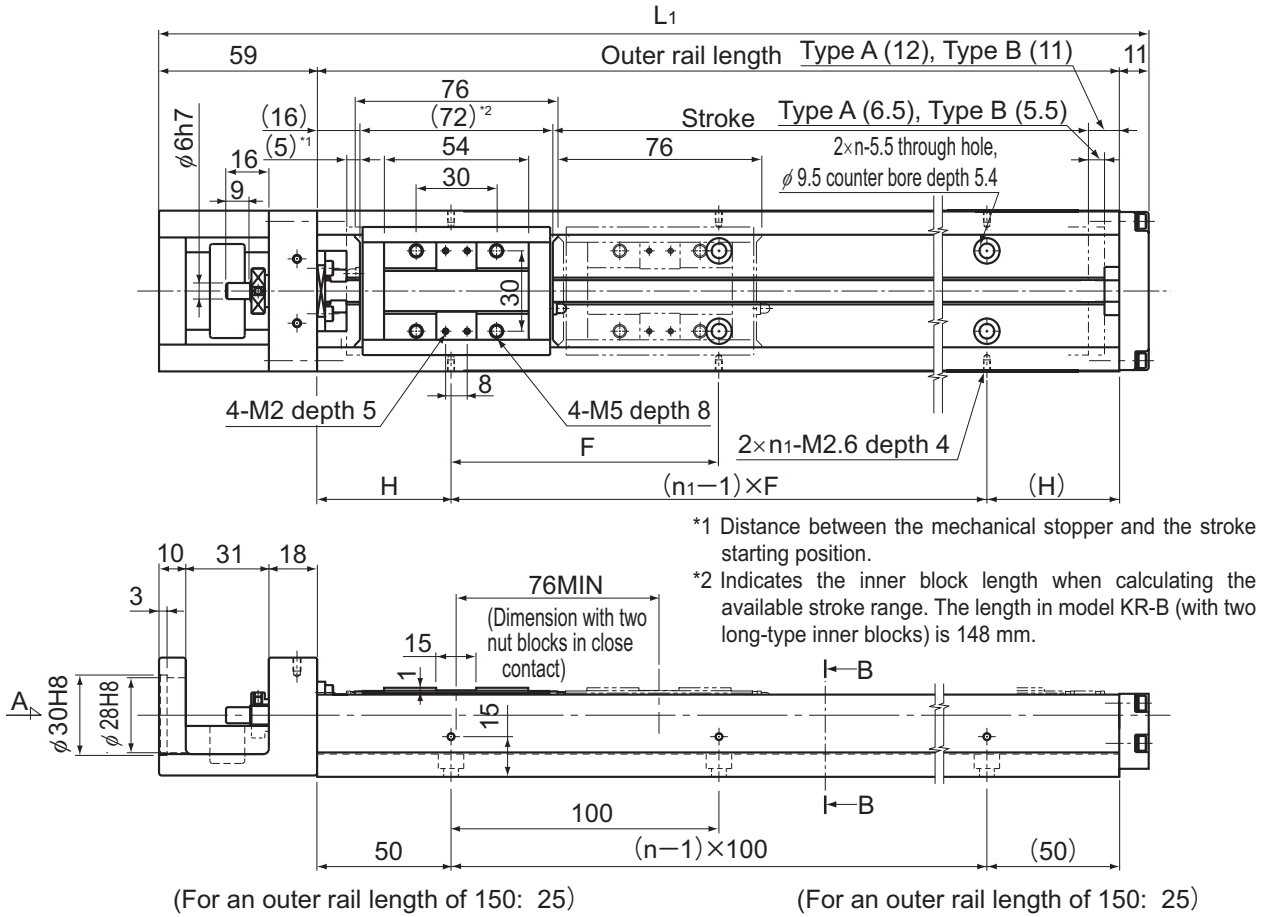

Stroke (mm) (stroke between mechanical stoppers)		Outer rail length (mm)	Overall length L ₁ (mm)	H (mm)	F (mm)	n	n ₁	Overall main unit mass (kg)	
Type A	Type B*							Type A	Type B
50(61.5)	—	150	220	25	100	2	2	1.7	—
100(111.5)	—	200	270	50	100	2	2	2	—
200(211.5)	125(135.5)	300	370	50	200	3	2	2.6	2.95
300(311.5)	225(235.5)	400	470	100	200	4	2	3.2	3.55
400(411.5)	325(335.5)	500	570	50	200	5	3	3.9	4.25
500(511.5)	425(435.5)	600	670	100	200	6	3	4.5	4.85
600(611.5)	525(535.5)	700	770	50	200	7	4	5.5	5.85

*Indicates a value when two inner blocks are in close contact with each other.

Model KR33 (with a Cover)

Model KR33□□A (with a Single Long Nut Block)

Model KR33□□B (with Two Long Nut Blocks)

For model number coding, see page31.

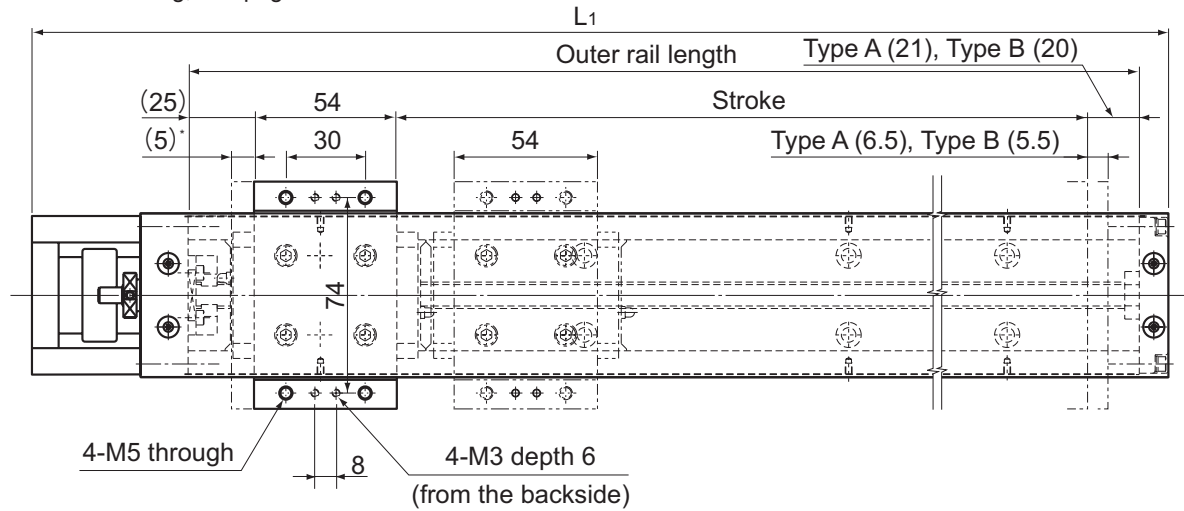

* Distance between the mechanical stopper and the stroke starting position.

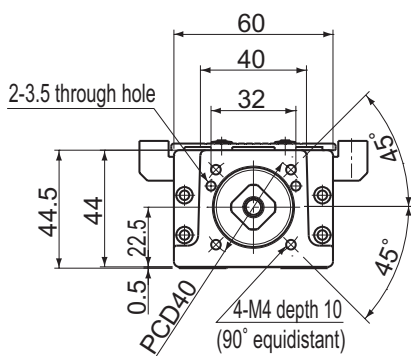
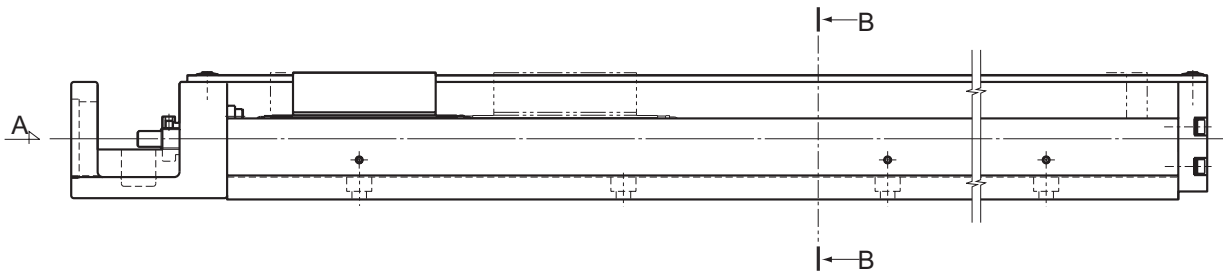

A arrow view

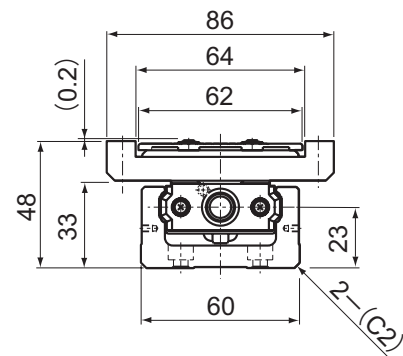

B-B cross section

Stroke (mm) (stroke between mechanical stoppers)		Outer rail length (mm)	Overall length L ₁ (mm)	Overall main unit mass (kg)	
Type A	Type B*			Type A	Type B
50(61.5)	—	150	220	1.9	—
100(111.5)	—	200	270	2.2	—
200(211.5)	125(135.5)	300	370	2.8	3.28
300(311.5)	225(235.5)	400	470	3.5	3.98
400(411.5)	325(335.5)	500	570	4.2	4.68
500(511.5)	425(435.5)	600	670	4.8	5.28
600(611.5)	525(535.5)	700	770	5.9	6.38

*Indicates a value when two inner blocks are in close contact with each other.

Note) It must be noted that the cover-mounting bolt is 0.2 mm higher than the top face of the sub table.

Model KR33 Standard Type

Model KR33□□C (with a Single Short Nut Block)

Model KR33□□D (with Two Short Nut Blocks)

For model number coding, see page31.

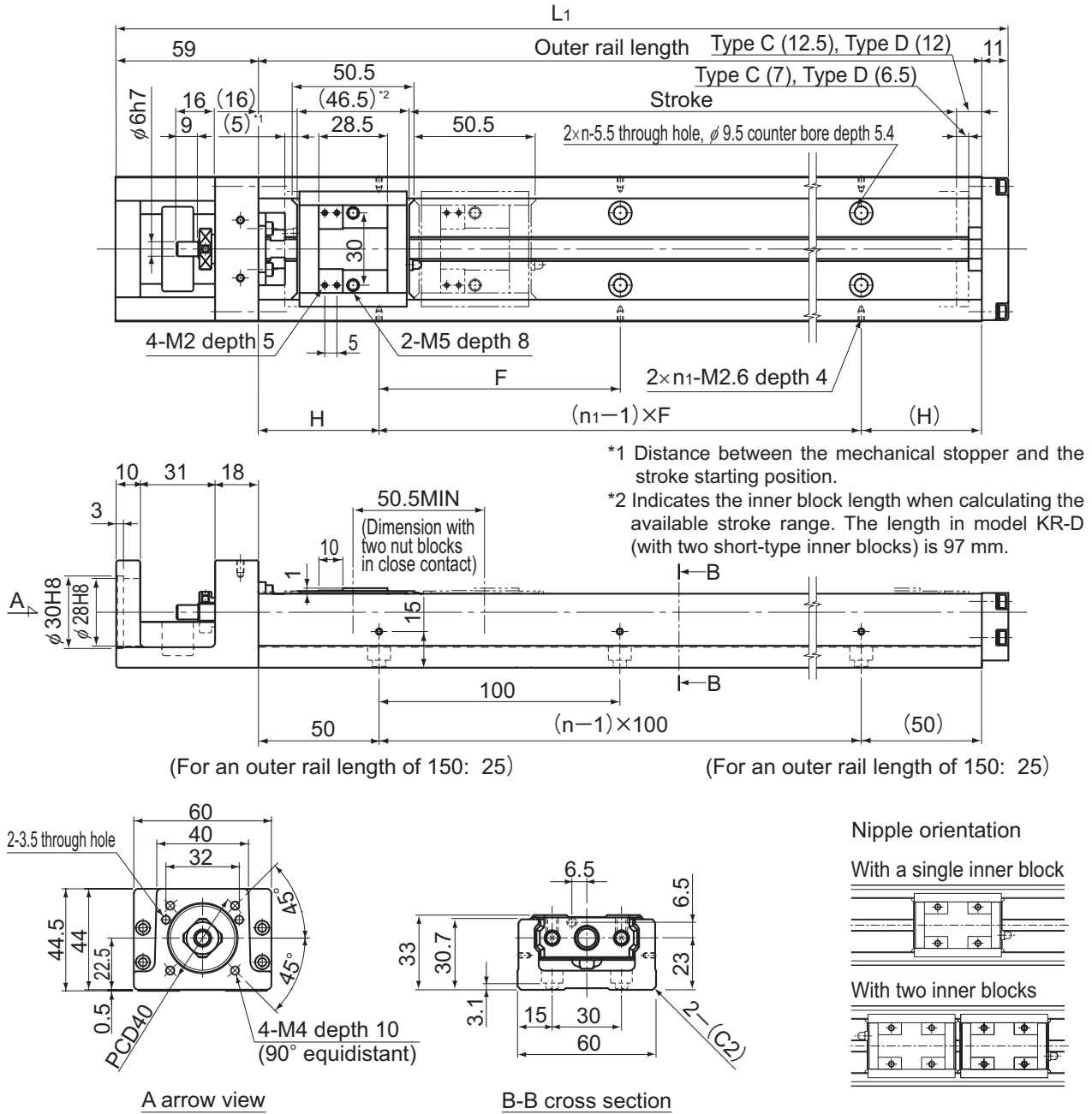

Stroke (mm) (stroke between mechanical stoppers)		Outer rail length (mm)	Overall length L_1 (mm)	H (mm)	F (mm)	n	n_1	Overall main unit mass (kg)	
Type C	Type D*							Type C	Type D
75(87)	25(36.5)	150	220	25	100	2	2	1.6	1.83
125(137)	75(86.5)	200	270	50	100	2	2	1.9	2.13
225(237)	175(186.5)	300	370	50	200	3	2	2.5	2.73
325(337)	275(286.5)	400	470	100	200	4	2	3.1	3.33
425(437)	375(386.5)	500	570	50	200	5	3	3.8	4.03
525(537)	475(486.5)	600	670	100	200	6	3	4.4	4.63
625(637)	575(586.5)	700	770	50	200	7	4	5.4	5.63

*Indicates a value when two inner blocks are in close contact with each other.

Model KR33 (with a Cover)

Model KR33□□C (with a Single Short Nut Block)

Model KR33□□D (with Two Short Nut Blocks)

For model number coding, see page31.

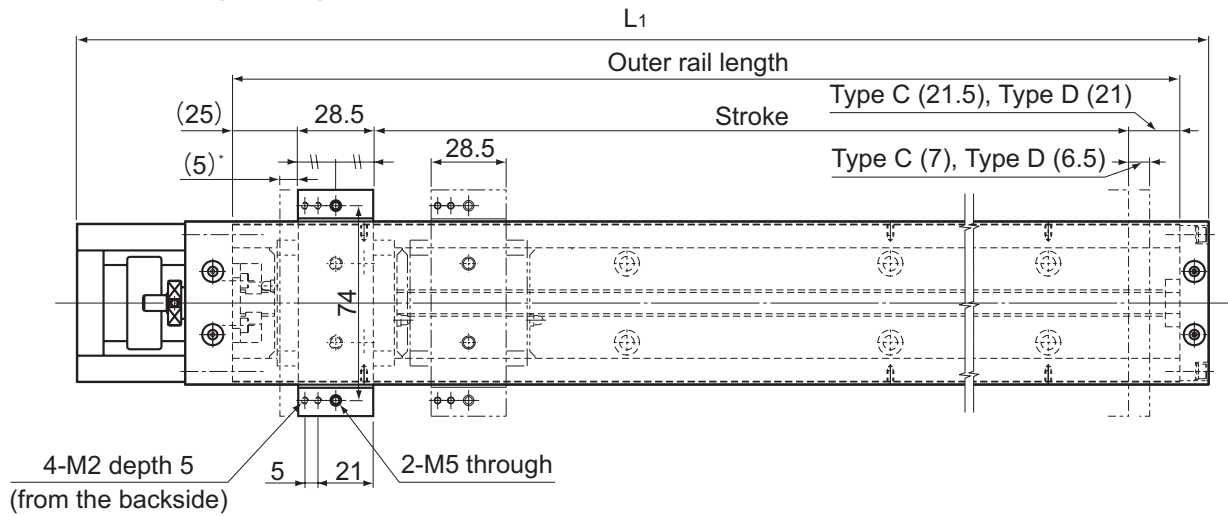

* Distance between the mechanical stopper and the stroke starting position.

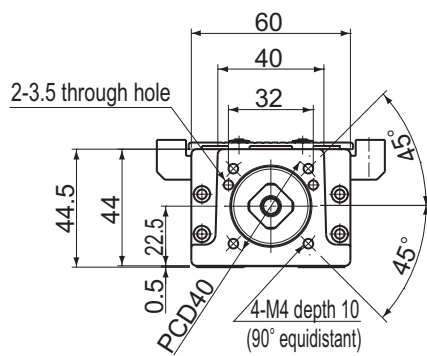
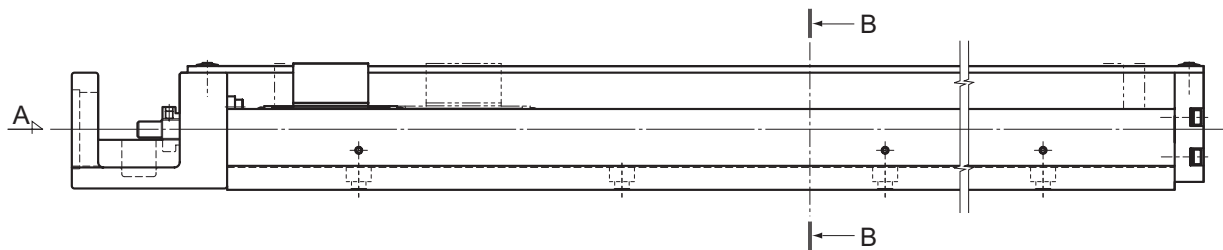

A arrow view

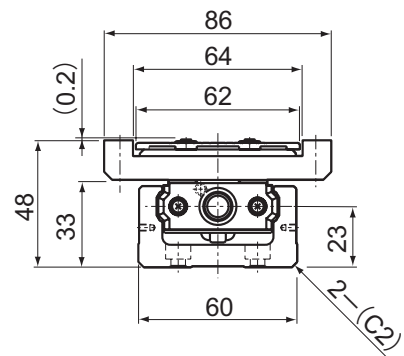

B-B cross section

Stroke (mm) (stroke between mechanical stoppers)		Outer rail length (mm)	Overall length L_1 (mm)	Overall main unit mass (kg)	
Type C	Type D*			Type C	Type D
75(87)	25(36.5)	150	220	1.7	2
125(137)	75(86.5)	200	270	2.1	2.4
225(237)	175(186.5)	300	370	2.7	3
325(337)	275(286.5)	400	470	3.3	3.6
425(437)	375(386.5)	500	570	4	4.3
525(537)	475(486.5)	600	670	4.7	5
625(637)	575(586.5)	700	770	5.7	5.93

*Indicates a value when two inner blocks are in close contact with each other.

Note) It must be noted that the cover-mounting bolt is 0.2 mm higher than the top face of the sub table.

Model KR45H Standard Type

Model KR45H□□A (with a Single Long Nut Block)

Model KR45H□□B (with Two Long Nut Blocks)

For model number coding, see page31.

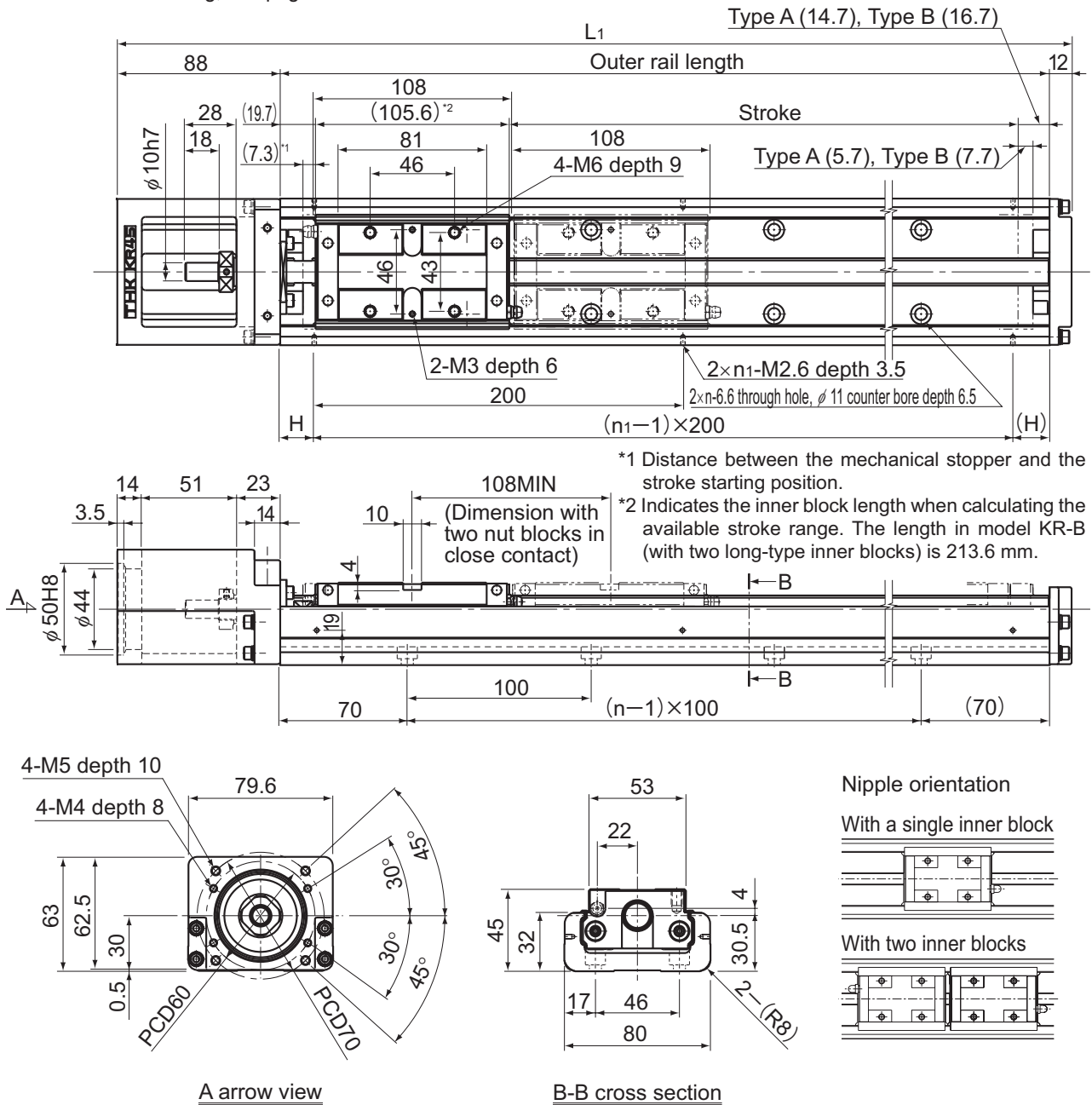

Stroke (mm) (stroke between mechanical stoppers)		Outer rail length (mm)	Overall length L ₁ (mm)	H (mm)	n	n ₁	Overall main unit mass (kg)	
Type A	Type B*						Type A	Type B
200(213)	90(105)	340	440	70	3	2	5.1	6.05
300(313)	190(205)	440	540	20	4	3	6.1	7.05
400(413)	290(305)	540	640	70	5	3	7.1	8.05
500(513)	390(405)	640	740	20	6	4	8.1	9.05
600(613)	490(505)	740	840	70	7	4	9.1	10.05
700(713)	590(605)	840	940	20	8	5	10.1	11.05
800(813)	690(705)	940	1040	70	9	5	11.2	12.15

*Indicates a value when two inner blocks are in close contact with each other.

Model KR45H (with a Cover)

Model KR45H□□A (with a Single Long Nut Block)

Model KR45H□□B (with Two Long Nut Blocks)

For model number coding, see page31.

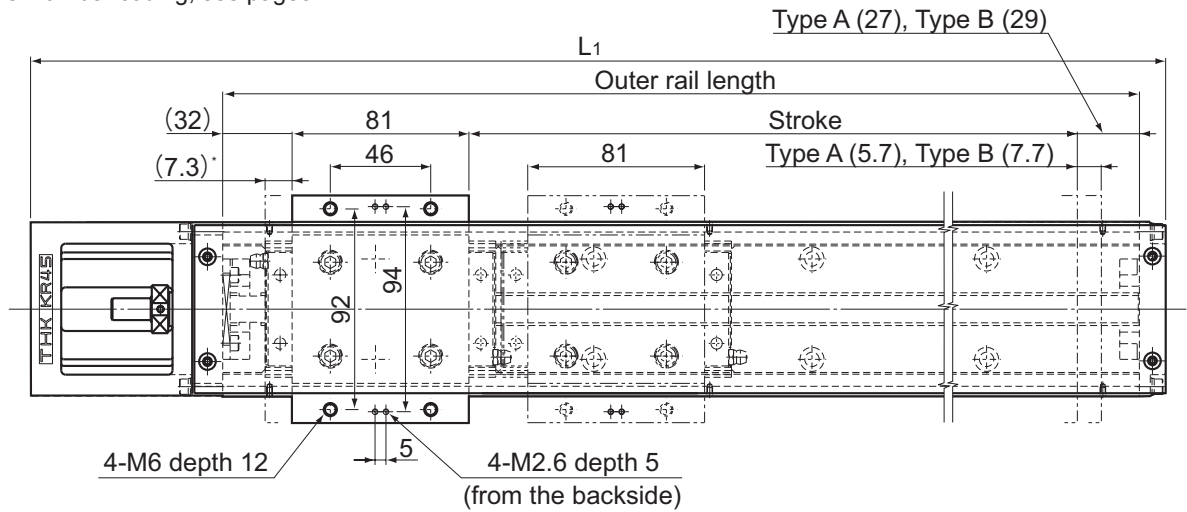

* Distance between the mechanical stopper and the stroke starting position.

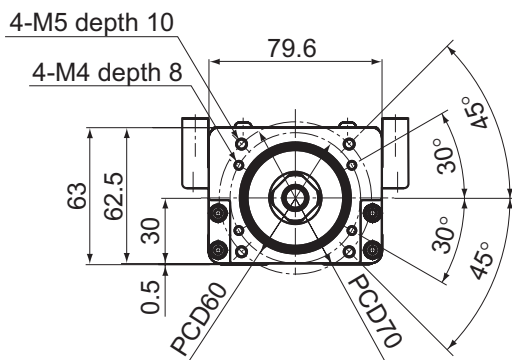
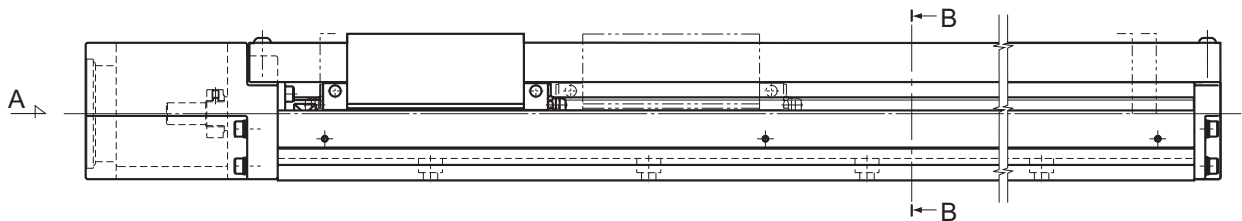

A arrow view

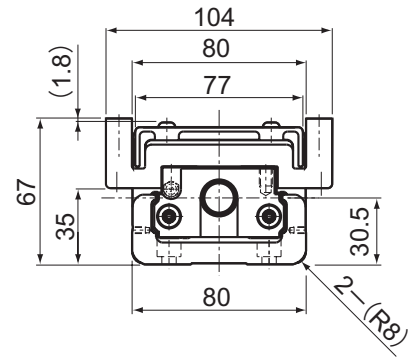

B-B cross section

Stroke (mm) (stroke between mechanical stoppers)		Outer rail length (mm)	Overall length L ₁ (mm)	Overall main unit mass (kg)	
Type A	Type B*			Type A	Type B
200(213)	90(105)	340	440	5.7	7.01
300(313)	190(205)	440	540	6.8	8.11
400(413)	290(305)	540	640	7.9	9.21
500(513)	390(405)	640	740	9	10.31
600(613)	490(505)	740	840	10.1	11.41
700(713)	590(605)	840	940	11.2	12.51
800(813)	690(705)	940	1040	12.3	13.61

*Indicates a value when two inner blocks are in close contact with each other.

Model KR45H Standard Type

Model KR45H□□C (with a Single Short Nut Block)

Model KR45H□□D (with Two Short Nut Blocks)

For model number coding, see page31.

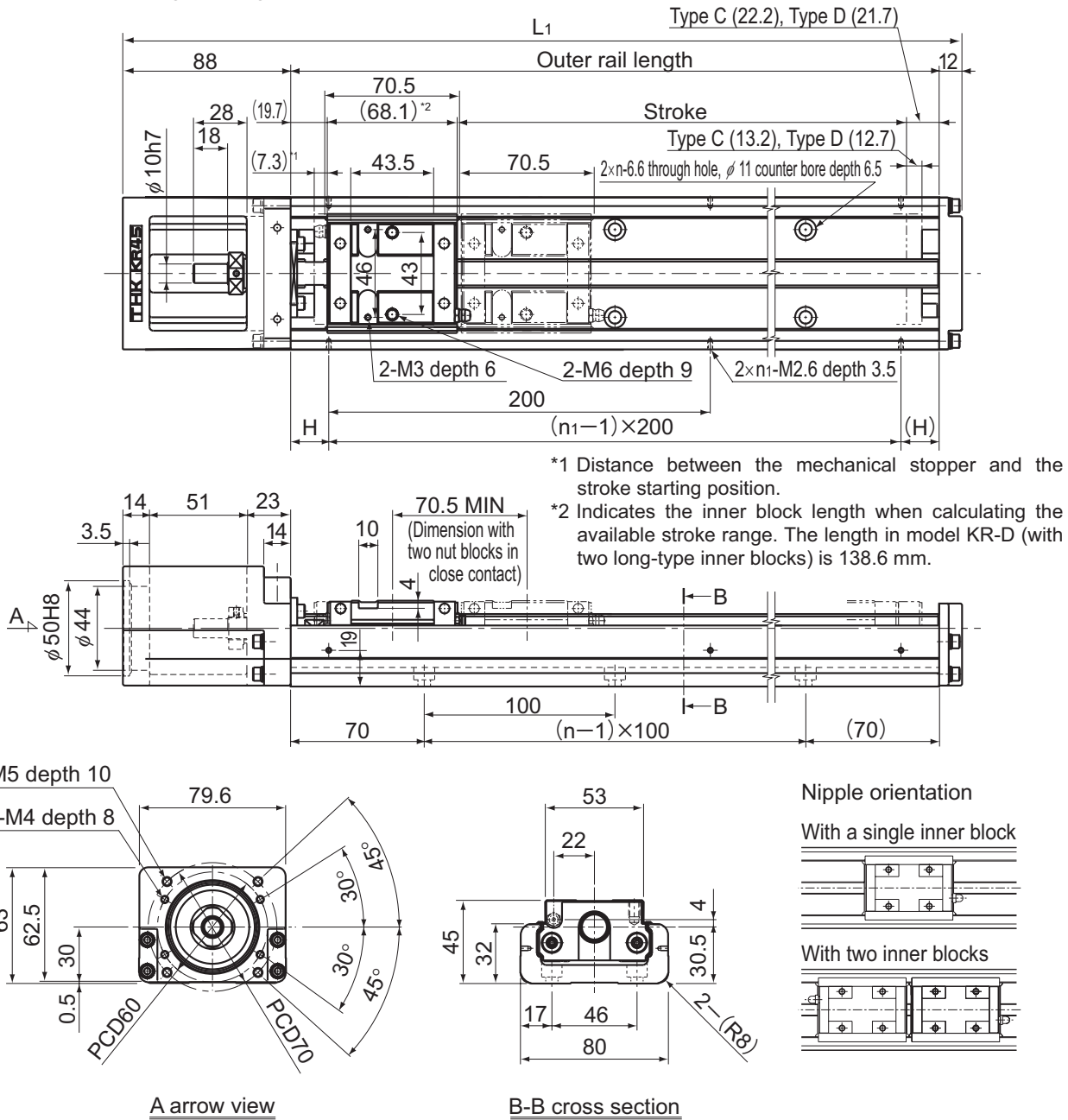

Stroke (mm) (stroke between mechanical stoppers)		Outer rail length (mm)	Overall length L_1 (mm)	H (mm)	n	n_1	Overall main unit mass (kg)	
Type C	Type D*						Type C	Type D
230(250.5)	160(180)	340	440	70	3	2	4.7	5.23
330(350.5)	260(280)	440	540	20	4	3	5.7	6.23
430(450.5)	360(380)	540	640	70	5	3	6.7	7.23
530(550.5)	460(480)	640	740	20	6	4	7.7	8.23
630(650.5)	560(580)	740	840	70	7	4	8.7	9.23
730(750.5)	660(680)	840	940	20	8	5	9.7	10.23
830(850.5)	760(780)	940	1040	70	9	5	10.8	11.33

*Indicates a value when two inner blocks are in close contact with each other.

Model KR45H (with a Cover)

Model KR45H□□C (with a Single Short Nut Block)

Model KR45H□□D (with Two Short Nut Blocks)

For model number coding, see page31.

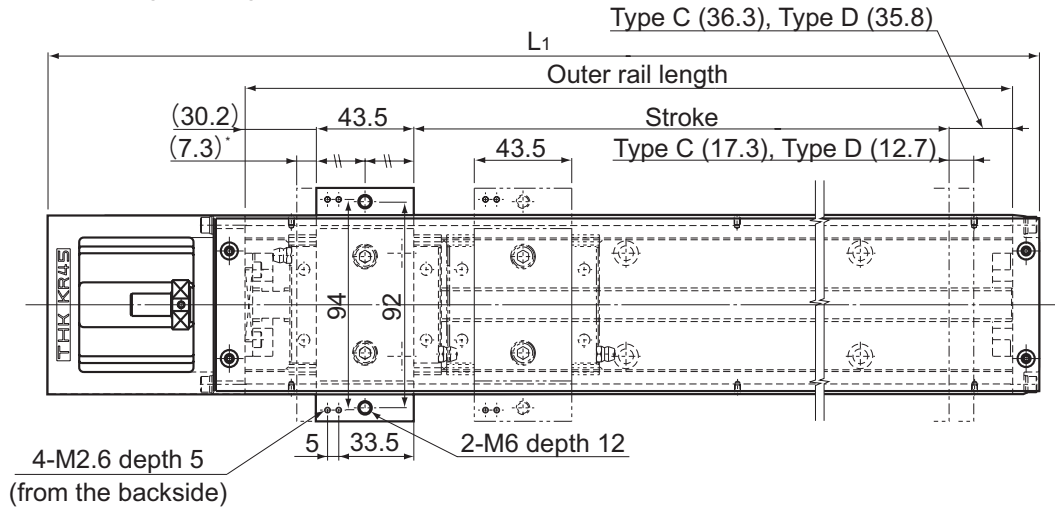

* Distance between the mechanical stopper and the stroke starting position.

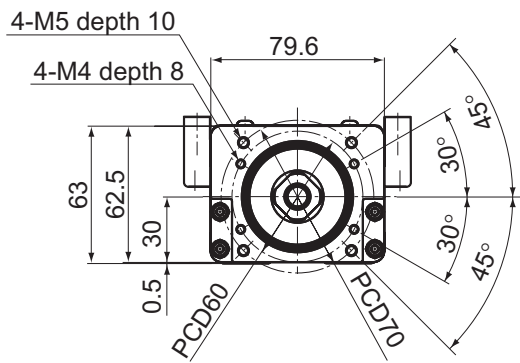
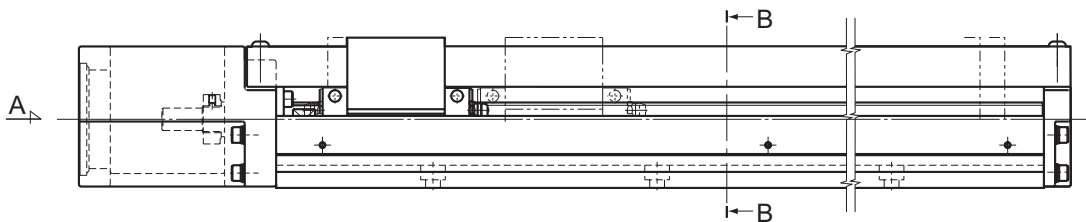

A arrow view

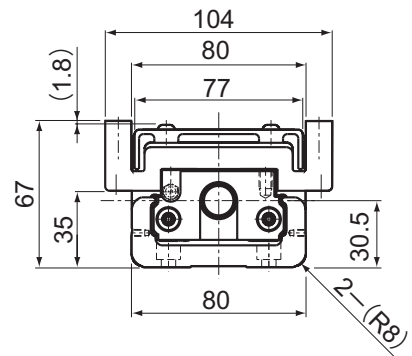

B-B cross section

Stroke (mm) (stroke between mechanical stoppers)		Outer rail length (mm)	Overall length L ₁ (mm)	Overall main unit mass (kg)	
Type C	Type D*			Type C	Type D
230(250.5)	160(180)	340	440	5.1	5.82
330(350.5)	260(280)	440	540	6.2	6.92
430(450.5)	360(380)	540	640	7.3	8.02
530(550.5)	460(480)	640	740	8.4	9.12
630(650.5)	560(580)	740	840	9.5	10.22
730(750.5)	660(680)	840	940	10.6	11.32
830(850.5)	760(780)	940	1040	11.7	12.42

*Indicates a value when two inner blocks are in close contact with each other.

Options⇒page60

Model KR46 Standard Type

Model KR46□□A (with a Single Long Nut Block)

Model KR46□□B (with Two Long Nut Blocks)

For model number coding, see page31.

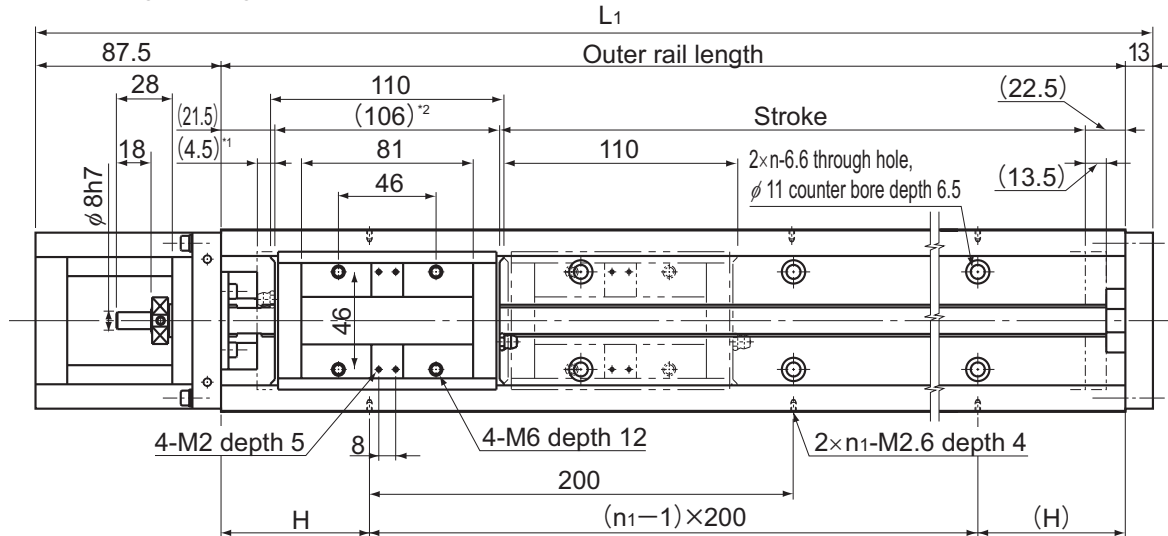

*1 Distance between the mechanical stopper and the stroke starting position.

*2 Indicates the inner block length when calculating the available stroke range. The length in model KR-B (with two long-type inner blocks) is 216 mm.

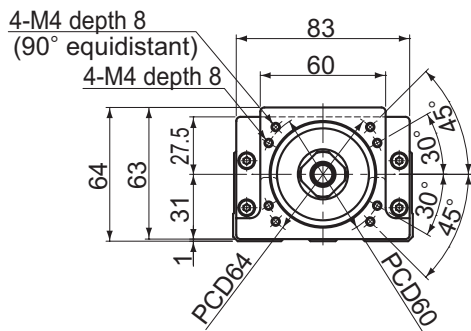
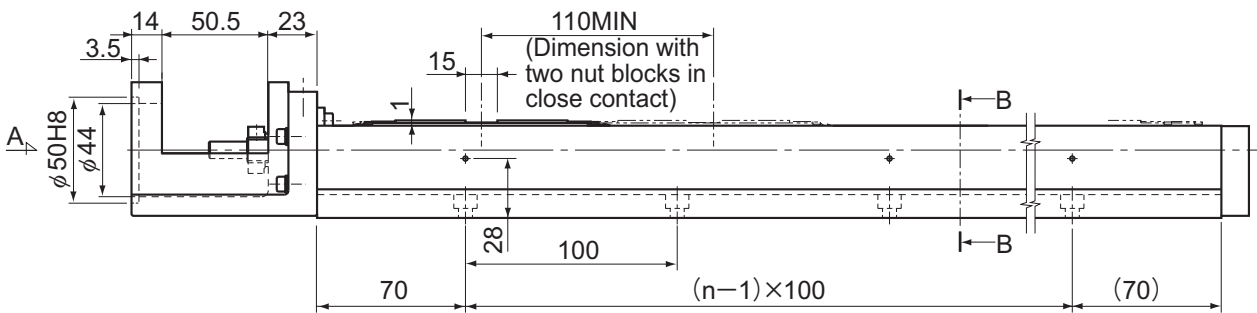

A arrow view

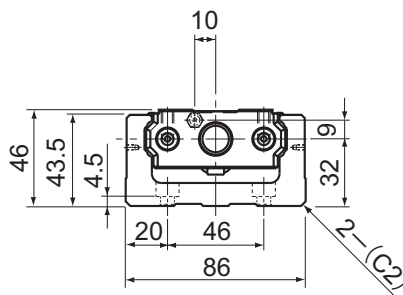

B-B cross section

Nipple orientation

With a single inner block

With two inner blocks

Stroke (mm) (stroke between mechanical stoppers)		Outer rail length (mm)	Overall length L ₁ (mm)	H (mm)	n	n ₁	Overall main unit mass (kg)	
Type A	Type B*						Type A	Type B
190(208)	80(98)	340	440.5	70	3	2	7.7	8.9
290(308)	180(198)	440	540.5	20	4	3	9	10.2
390(408)	280(298)	540	640.5	70	5	3	10.3	11.5
490(508)	380(398)	640	740.5	20	6	4	11.6	12.8
590(608)	480(498)	740	840.5	70	7	4	12.8	14
690(708)	580(598)	840	940.5	20	8	5	14.1	15.3
790(808)	680(698)	940	1040.5	70	9	5	15.3	16.5

*Indicates a value when two inner blocks are in close contact with each other.

Model KR46 (with a Cover)

Model KR46□□A (with a Single Long Nut Block)

Model KR46□□B (with Two Long Nut Blocks)

For model number coding, see page31.

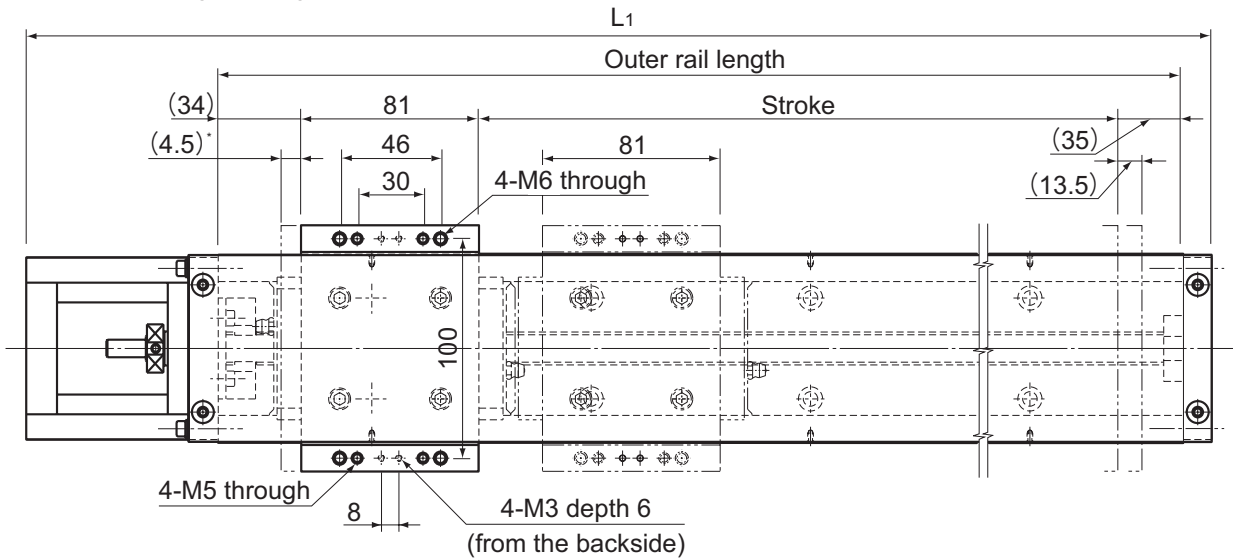

* Distance between the mechanical stopper and the stroke starting position.

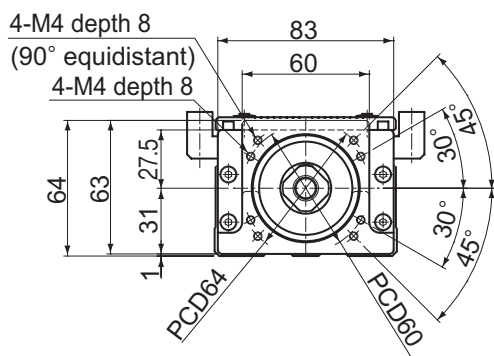
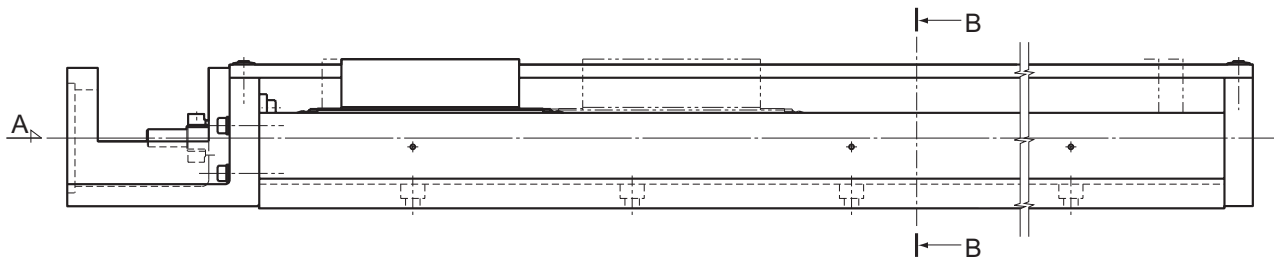

A arrow view

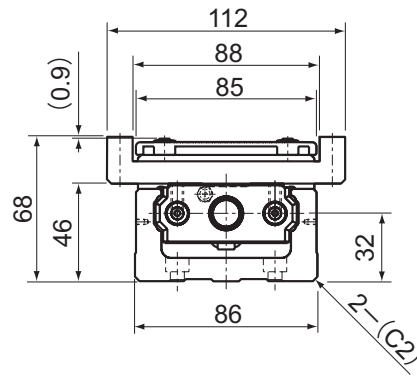

B-B cross section

Stroke (mm) (stroke between mechanical stoppers)		Outer rail length (mm)	Overall length L ₁ (mm)	Overall main unit mass (kg)	
Type A	Type B*			Type A	Type B
190(208)	80(98)	340	440.5	8.3	9.79
290(308)	180(198)	440	540.5	9.7	11.19
390(408)	280(298)	540	640.5	11	12.49
490(508)	380(398)	640	740.5	12.4	13.89
590(608)	480(498)	740	840.5	13.7	15.19
690(708)	580(598)	840	940.5	15	16.49
790(808)	680(698)	940	1040.5	16.3	17.79

*Indicates a value when two inner blocks are in close contact with each other.

Options⇒page60

Model KR46 Standard Type

Model KR46□□C (with a Single Short Nut Block)

Model KR46□□D (with Two Short Nut Blocks)

For model number coding, see page31.

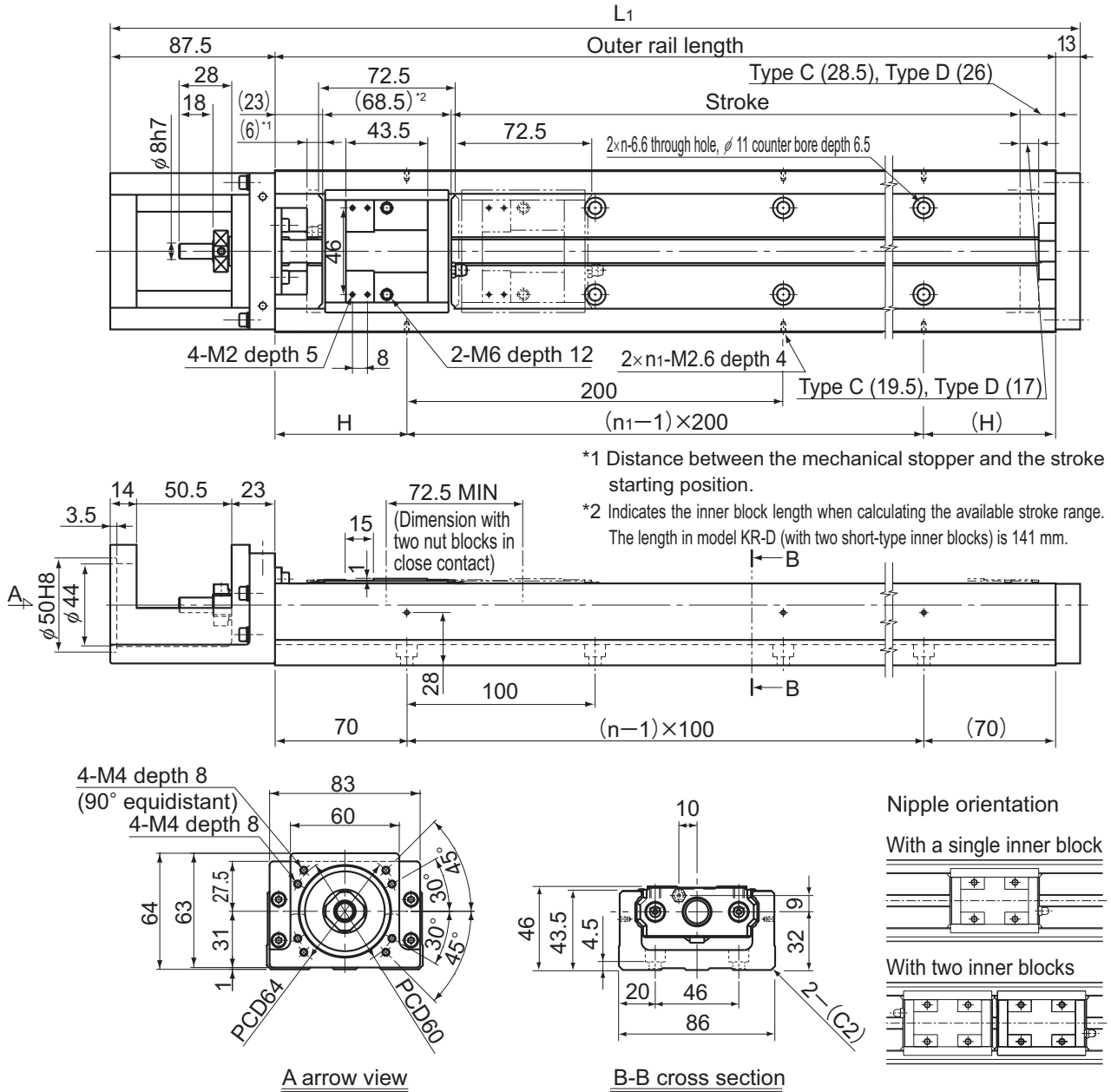

Stroke (mm) (stroke between mechanical stoppers)		Outer rail length (mm)	Overall length L ₁ (mm)	H (mm)	n	n ₁	Overall main unit mass (kg)	
Type C	Type D*						Type C	Type D
220(245.5)	150(173)	340	440.5	70	3	2	7.3	8.1
320(345.5)	250(273)	440	540.5	20	4	3	8.6	9.4
420(445.5)	350(373)	540	640.5	70	5	3	9.9	10.7
520(545.5)	450(473)	640	740.5	20	6	4	11.2	12
620(645.5)	550(573)	740	840.5	70	7	4	12.4	13.2
720(745.5)	650(673)	840	940.5	20	8	5	13.7	14.5
820(845.5)	750(773)	940	1040.5	70	9	5	14.9	15.7

*Indicates a value when two inner blocks are in close contact with each other.

Model KR46 (with a Cover)

Model KR46□□C (with a Single Short Nut Block)

Model KR46□□D (with Two Short Nut Blocks)

For model number coding, see page31.

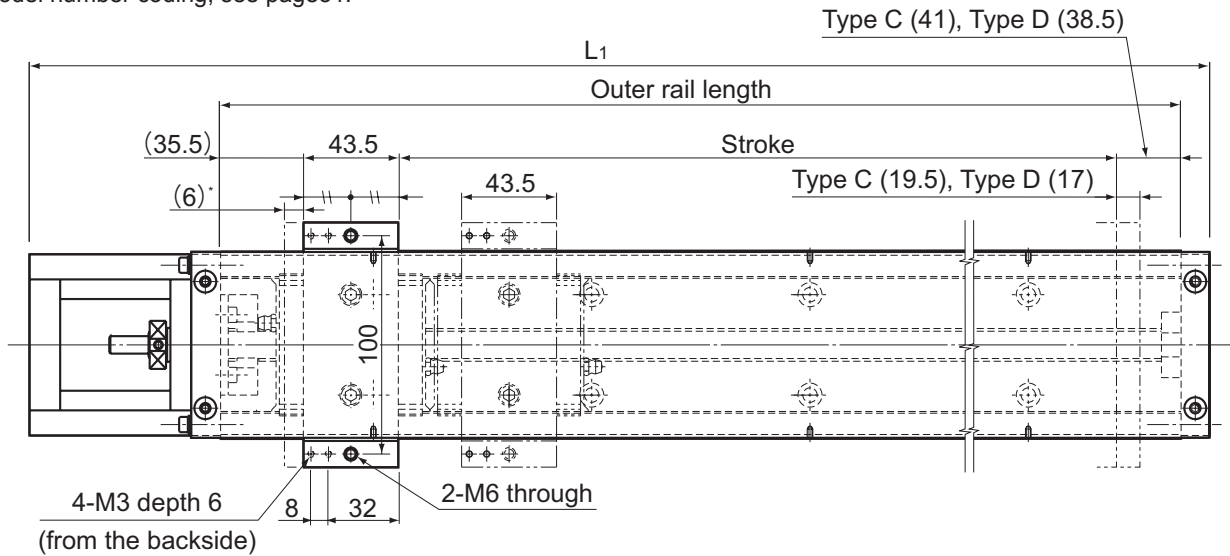

* Distance between the mechanical stopper and the stroke starting position.

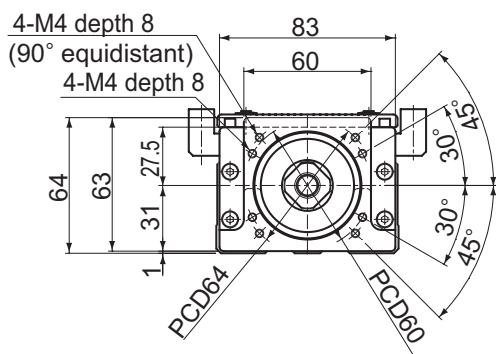
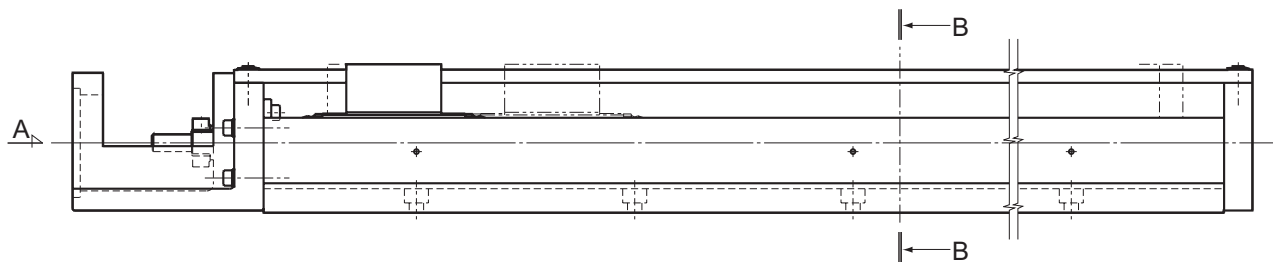

A arrow view

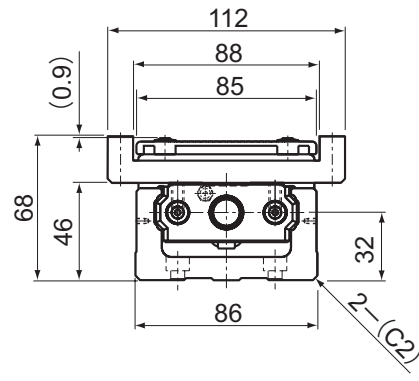

B-B cross section

Stroke (mm) (stroke between mechanical stoppers)		Outer rail length (mm)	Overall length L ₁ (mm)	Overall main unit mass (kg)	
Type C	Type D*			Type C	Type D
220(245.5)	150(173)	340	440.5	7.8	8.79
320(345.5)	250(273)	440	540.5	9.1	10.09
420(445.5)	350(373)	540	640.5	10.5	11.49
520(545.5)	450(473)	640	740.5	11.9	12.89
620(645.5)	550(573)	740	840.5	13.2	14.19
720(745.5)	650(673)	840	940.5	14.5	15.49
820(845.5)	750(773)	940	1040.5	15.8	16.79

*Indicates a value when two inner blocks are in close contact with each other.

Model KR55 Standard Type

Model KR5520A (with a Single Long Nut Block)

Model KR5520B (with Two Long Nut Blocks)

For model number coding, see page31.

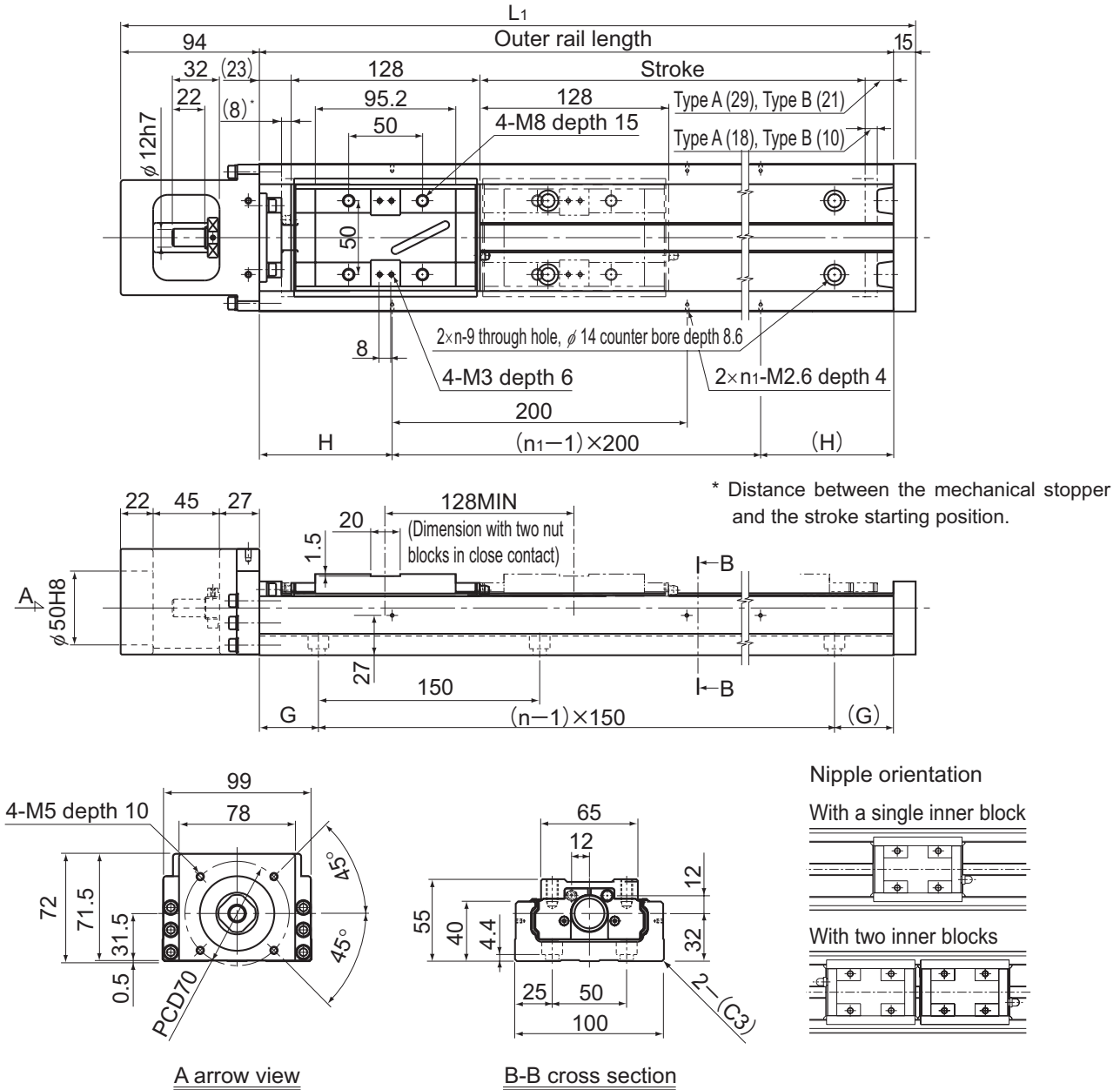

Stroke (mm) (stroke between mechanical stoppers)		Outer rail length (mm)	Overall length L ₁ (mm)	H (mm)	G (mm)	n	n ₁	Overall main unit mass (kg)	
Type A	Type B*							Type A	Type B
800(826)	680(698)	980	1089	90	40	7	5	19.9	21.6
900(926)	780(798)	1080	1189	40	15	8	6	21.7	23.4
1000(1026)	880(898)	1180	1289	90	65	8	6	23.4	25.1
1100(1126)	980(998)	1280	1389	40	40	9	7	25.1	26.8
1200(1226)	1080(1098)	1380	1489	90	15	10	7	26.9	28.6

*Indicates a value when two inner blocks are in close contact with each other.

Model KR55 (with a Cover)

Model KR5520A (with a Single Long Nut Block)

Model KR5520B (with Two Long Nut Blocks)

For model number coding, see page31.

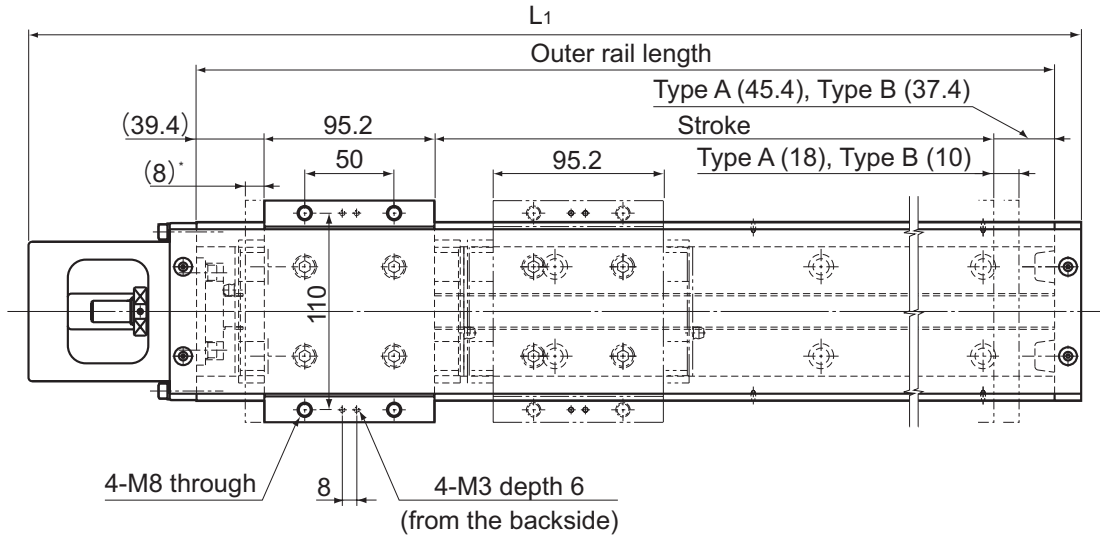

* Distance between the mechanical stopper and the stroke starting position.

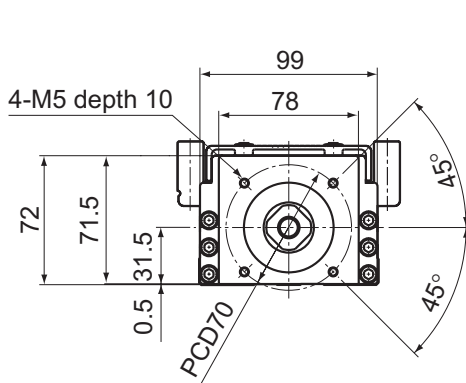
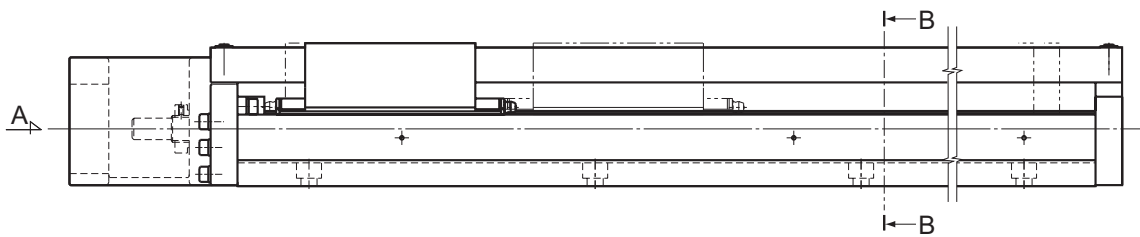

A arrow view

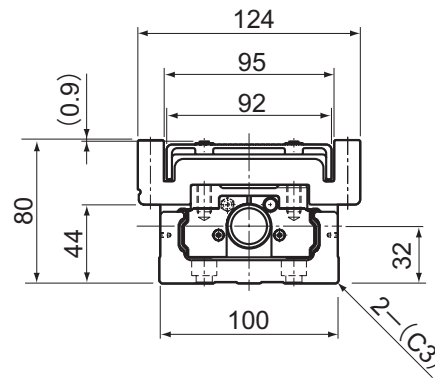

B-B cross section

Stroke (mm) (stroke between mechanical stoppers)		Outer rail length (mm)	Overall length L ₁ (mm)	Overall main unit mass (kg)	
Type A	Type B*			Type A	Type B
800(826)	680(698)	980	1089	22.7	26.2
900(926)	780(798)	1080	1189	24.6	28.1
1000(1026)	880(898)	1180	1289	26.4	29.9
1100(1126)	980(998)	1280	1389	28.1	31.6
1200(1226)	1080(1098)	1380	1489	30	33.5

*Indicates a value when two inner blocks are in close contact with each other.

Model KR65 Standard Type

Model KR6525A (with a Single Long Nut Block)

Model KR6525B (with Two Long Nut Blocks)

For model number coding, see page31.

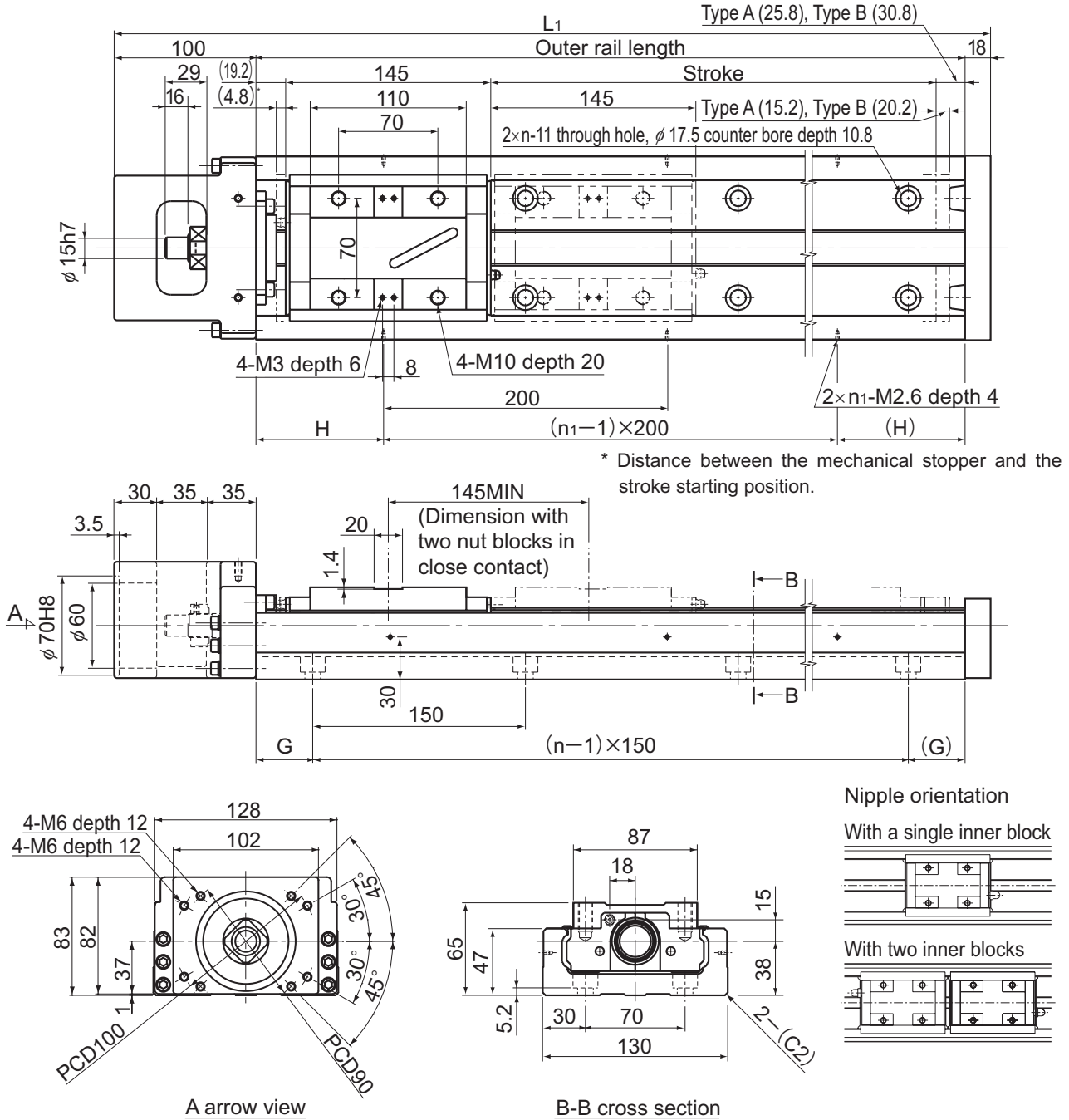

Stroke (mm) (stroke between mechanical stoppers)		Outer rail length (mm)	Overall length L_1 (mm)	H (mm)	G (mm)	n	n_1	Overall main unit mass (kg)	
Type A	Type B*							Type A	Type B
790(810)	640(665)	980	1098	90	40	7	5	31.6	34.6
990(1010)	840(865)	1180	1298	90	65	8	6	37	40
1190(1210)	1040(1065)	1380	1498	90	90	9	7	42.4	45.4
1490(1510)	1340(1365)	1680	1798	40	90	11	9	50.5	53.5

*Indicates a value when two inner blocks are in close contact with each other.

Model KR65 (with a Cover)

Model KR6525A (with a Single Long Nut Block)

Model KR6525B (with Two Long Nut Blocks)

For model number coding, see page31.

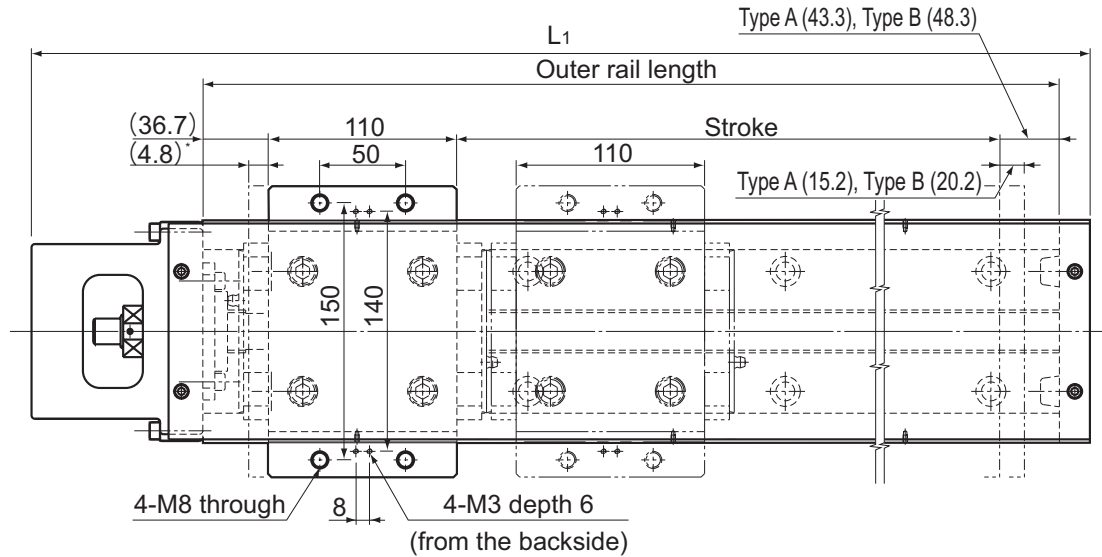

* Distance between the mechanical stopper and the stroke starting position.

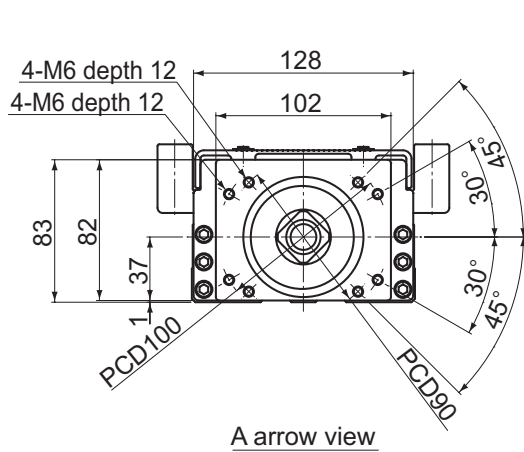
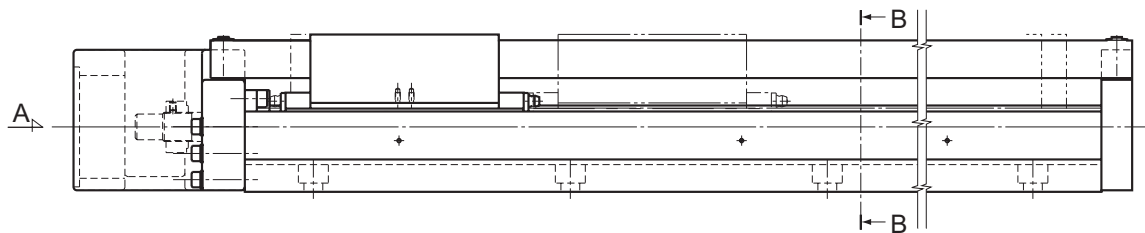

A arrow view

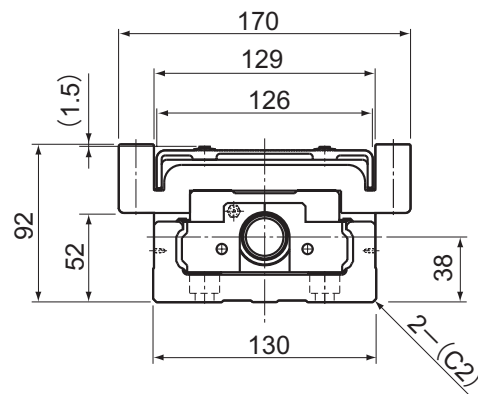

B-B cross section

Stroke (mm) (stroke between mechanical stoppers)		Outer rail length (mm)	Overall length L ₁ (mm)	Overall main unit mass (kg)	
Type A	Type B*			Type A	Type B
790(810)	640(665)	980	1098	36.3	43
990(1010)	840(865)	1180	1298	42	48.7
1190(1210)	1040(1065)	1380	1498	47.6	54.3
1490(1510)	1340(1365)	1680	1798	56.1	62.8

*Indicates a value when two inner blocks are in close contact with each other.

Mass of Moving Element

Table13 shows the mass of the inner block and Sub table of model KR.

Table13 Mass of the Inner Block and Sub table of KR

Unit: kg

Model No.	Long nut block types (A)		Short nut block types (C)	
	Inner block	Sub table	Inner block	Sub table
KR15	0.042	0.022	—	—
KR20	0.075	0.045	—	—
KR26	0.180	0.085	—	—
KR30H	0.30	0.13	0.17	0.07
KR33	0.35	0.13	0.23	0.07
KR45H	0.95	0.36	0.53	0.19
KR46	1.20	0.29	0.80	0.19
KR55	1.70	1.80	—	—
KR65	3.00	3.70	—	—

Options

Bellows

For model KR, bellows are available for contamination protection in addition to a cover.

[Model KR-A (with a Single Long Nut Block)]

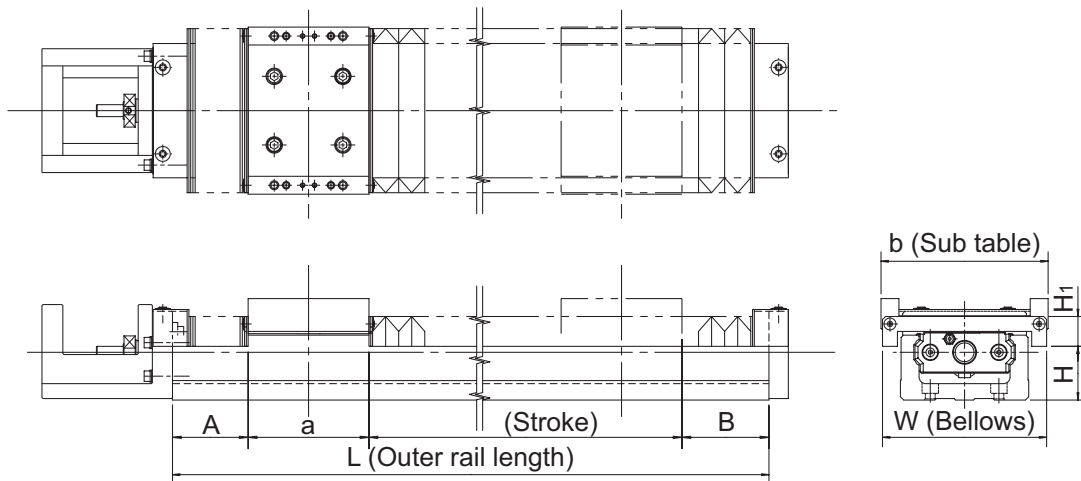

Unit: mm

Model No.	Stroke*1	Outer rail length L	A	B	a	b	W	H	H ₁
KR15	15(22.2)	75	15.8	14	23	44	49	8	15.5
	30(37.2)	100	20.8	19					
	45(52.2)	125	25.8	24					
	60(67.2)	150	30.8	29					
	75(82.2)	175	35.8	34					
90(97.2)	200	40.8	39						
KR20	20(30.8)	100	18.8	17.2	33.2	52	60	10	20
	55(67.8)	150	25.3	23.7					
	80(93.6)	200	37	36.2					
KR26	50(61.3)	150	23.7	17.6	47.4	62	74	18	20
	80(91.6)	200	32.8	28.2					
	110(125.6)	250	40.8	36.2					
	160(175.6)	300	40.8	36.2					
KR30H	30(42)	150	28.5	25.5	54	80	80	21.5	17.5
	60(72)	200	38.5	35.5					
	130(142)	300	53.5	50.5					
	200(212)	400	68.5	65.5					
	270(282)	500	83.5	80.5					
	340(352)	600	98.5	95.5					
KR33	30(42)	150	28.4	25.6	54	86	84	24.5	20
	70(82)	200	33.4	30.6					
	150(162)	300	43.4	40.6					
	220(232)	400	58.4	55.6					
	300(312)	500	68.4	65.6					
	370(382)	600	83.4	80.6					
450(462)	700	93.4	90.6						

Model No.	Stroke*1	Outer rail length L	A	B	a	b	W	H	H ₁
KR45H	160(177)	340	41.1	40.9	81	104	104	28	28
	240(255)	440	52.1	51.9					
	320(339)	540	60.1	59.9					
	400(423)	640	68.1	67.9					
	470(491)	740	84.1	83.9					
	550(575)	840	92.1	91.9					
	640(659)	940	100.1	99.9					
KR46	140(155)	340	52.9	51.1	81	112	110	36	20
	210(225)	440	67.9	66.1					
	290(305)	540	77.9	76.1					
	360(375)	640	92.9	91.1					
	440(455)	740	102.9	101.1					
	510(525)	840	117.9	116.1					
	590(605)	940	127.9	126.1					
KR55	700(719.6)	980	84.6	80.6	95.2	124	154	37	40
	790(809.6)	1080	89.6	85.6					
	870(889.6)	1180	99.6	95.6					
	960(979.6)	1280	104.6	100.6					
	1050(1069.6)	1380	109.6	105.6					
KR65	680(703.2)	980	85.1	81.7	110	170	184	40	47
	860(883.2)	1180	95.1	91.7					
	1030(1053.2)	1380	110.1	106.7					
	1290(1313.2)	1680	130.1	126.7					

*1 The value in the parentheses represents the maximum stroke.

*2 The bellows for KR55 and KR65 are only suitable for horizontal orientation. If the bellows is to be used in other orientations (vertical or wall-mounted), contact THK.

[Model KR-B (with Two Long Nut Blocks)]

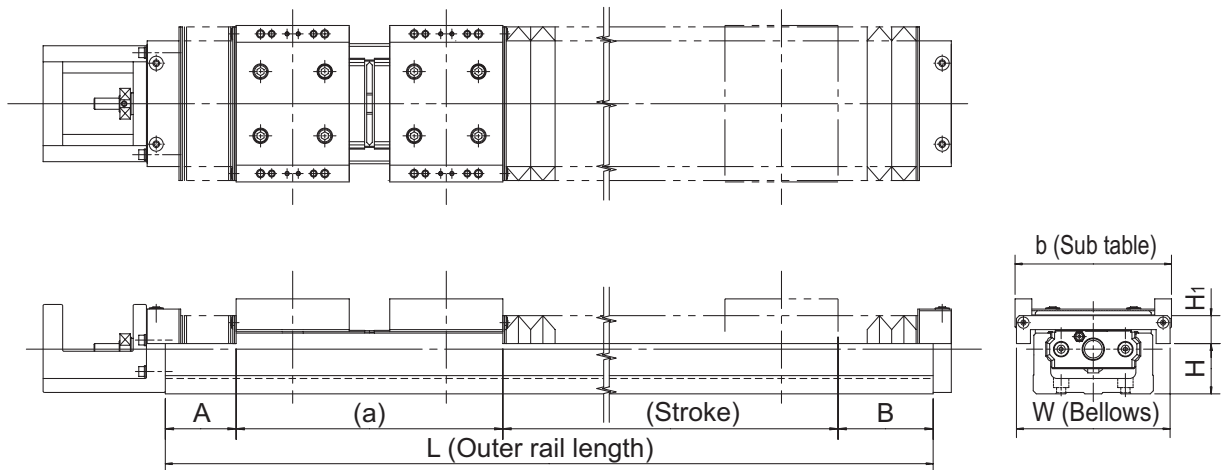

Unit: mm

Model No.	Stroke ^{*1,*2}	Outer rail length L	A	B	a	b	W	H	H ₁
KR15	20(29.2)	125	20.8	19	56	44	49	8	15.5
	35(44.2)	150	25.8	24					
	50(59.2)	175	30.8	29					
	65(74.2)	200	35.8	34					
KR20	25(34.8)	150	18.8	17.2	79.2	52	60	10	20
	60(71.8)	200	25.3	23.7					
KR26	35(47.3)	200	23.7	17.6	111.4	62	74	18	20
	65(77.6)	250	32.8	28.2					
	115(127.6)	300	32.8	28.2					
KR30H	85(97.6)	300	38.5	35.5	128.4	80	80	21.5	17.5
	155(167.6)	400	53.5	50.5					
	225(237.6)	500	68.5	65.5					
	295(307.6)	600	83.5	80.5					
KR33	80(96)	300	38.4	35.6	130	86	84	24.5	20
	160(176)	400	48.4	45.6					
	240(256)	500	58.4	55.6					
	310(326)	600	73.4	70.6					
	390(406)	700	83.4	80.6					
KR45H	80(95)	340	28.1	27.9	189	104	104	28	28
	155(170.5)	440	41.1	39.4					
	230(247)	540	52.1	51.9					
	310(331)	640	60.1	59.9					
	400(415)	740	68.1	67.9					
	465(483)	840	84.1	83.9					
KR46	60(75)	340	37.9	36.1	191	112	110	36	20
	130(145)	440	52.9	51.1					
	210(225)	540	62.9	61.1					
	280(295)	640	77.9	76.1					
	360(375)	740	87.9	86.1					
	430(445)	840	102.9	101.1					
KR55	590(612)	980	74.6	70.6	222.8	124	154	37	40
	670(692)	1080	84.6	80.6					
	760(782)	1180	89.6	85.6					
	850(872)	1280	94.6	90.6					
	930(952)	1380	104.6	100.6					
KR65	550(578.6)	980	75.1	71.7	254.6	170	184	40	47
	720(748.6)	1180	90.1	86.7					
	900(928.6)	1380	100.1	96.7					
	1160(1188.6)	1680	120.1	116.7					

*1 The strokes in the table are values when the blocks are in close contact with each other.

*2 The value in the parentheses represents the maximum stroke.

*3 The bellows for KR55 and KR65 are only suitable for horizontal orientation. If the bellows is to be used in other orientations (vertical or wall-mounted), contact THK.

Note) The bellows cannot be attached between the sub tables.

[Model KR-C (with a Single Short Nut Block)]

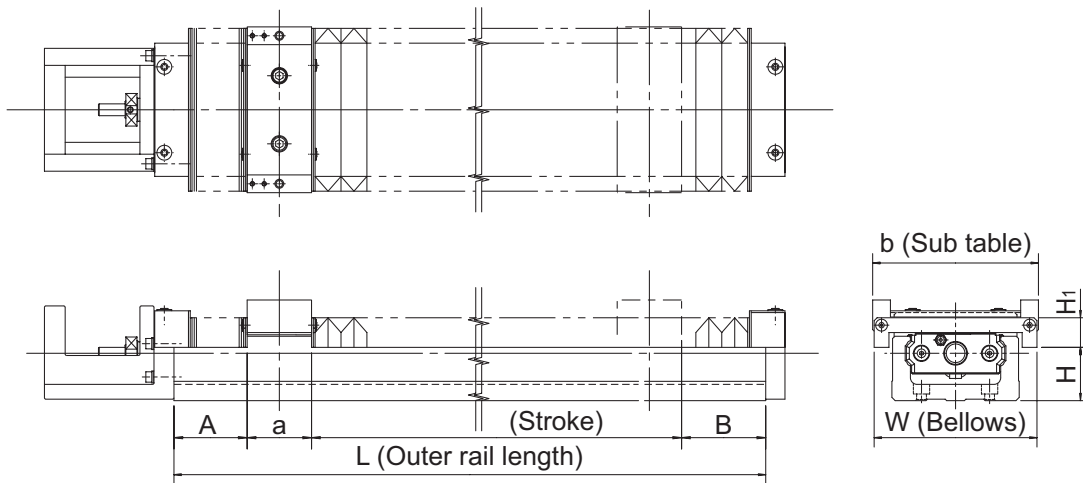

Unit: mm

Model No.	Stroke*	Outer rail length L	A	B	a	b	W	H	H _i
KR30H	45(57.5)	150	33.5	30.5	28.5	80	80	21.5	17.5
	85(97.5)	200	38.5	35.5					
	155(167.5)	300	53.5	50.5					
	225(237.5)	400	68.5	65.5					
	295(307.5)	500	83.5	80.5					
	365(377.5)	600	98.5	95.5					
KR33	55(67.5)	150	28.4	25.6	28.5	86	84	24.5	20
	95(107.5)	200	33.4	30.6					
	165(177.5)	300	48.4	45.6					
	245(257.5)	400	58.4	55.6					
	315(327.5)	500	73.4	70.6					
	395(407.5)	600	83.4	80.6					
	465(477.5)	700	98.4	95.6					
KR45H	190(208.5)	340	44.1	43.9	43.5	104	104	28	28
	275(292.5)	440	52.1	51.9					
	340(360.5)	540	68.1	67.9					
	425(444.5)	640	76.1	75.9					
	510(528.5)	740	84.1	83.9					
	580(596.5)	840	100.1	99.9					
	660(680.5)	940	108.1	107.9					
KR46	170(182.5)	340	57.9	56.1	43.5	112	110	36	20
	240(252.5)	440	72.9	71.1					
	320(332.5)	540	82.9	81.1					
	390(402.5)	640	97.9	96.1					
	470(482.5)	740	107.9	106.1					
	540(552.5)	840	122.9	121.1					
	620(632.5)	940	132.9	131.1					

*The value in the parentheses represents the maximum stroke.

[Model KR-D (with Two Short Nut Blocks)]

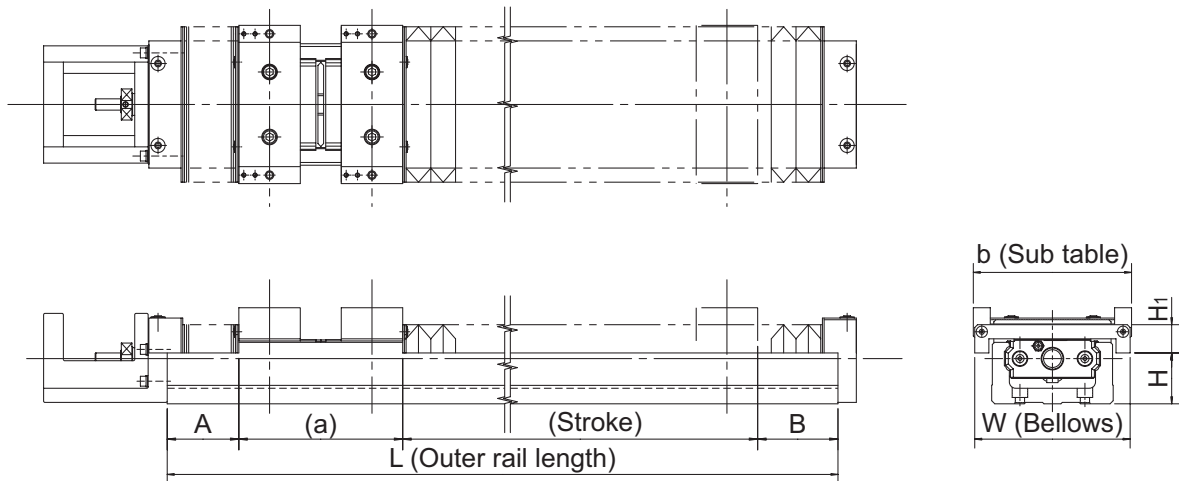

Unit: mm

Model No.	Stroke ^{*1,*2}	Outer rail length L	A	B	a	b	W	H	H ₁
KR30H	15(28.6)	150	23.5	20.5	77.4	80	80	21.5	17.5
	45(58.6)	200	33.5	30.5					
	115(128.6)	300	48.5	45.5					
	185(198.6)	400	63.5	60.5					
	255(268.6)	500	78.5	75.5					
	325(338.6)	600	93.5	90.5					
KR33	55(67)	200	28.4	25.6	79	86	84	24.5	20
	125(137)	300	43.4	40.6					
	205(217)	400	53.4	50.6					
	275(287)	500	68.4	65.6					
	355(367)	600	78.4	75.6					
	425(437)	700	93.4	90.6					
KR45H	140(154)	340	36.1	35.9	114	104	104	28	28
	220(238)	440	44.1	43.9					
	290(306)	540	60.1	59.9					
	370(390)	640	68.1	67.9					
	455(474)	740	76.1	75.9					
	525(542)	840	92.1	91.9					
	605(626)	940	100.1	99.9					
KR46	110(130)	340	47.9	46.1	116	112	110	36	20
	180(200)	440	62.9	61.1					
	260(280)	540	72.9	71.1					
	330(350)	640	87.9	86.1					
	410(430)	740	97.9	96.1					
	480(500)	840	112.9	111.1					
	560(580)	940	122.9	121.1					

*1 The strokes in the table are values when the blocks are in close contact with each other.

*2 The value in the parentheses represents the maximum stroke.

Note) The bellows cannot be attached between the sub tables.

Sensor

Optional proximity sensors and photo sensors are available for model KR. Models equipped with a sensor are also provided with a dedicated sensor rail/sensor dog.

If the stroke is less than 70mm, 2 sensor flag and 2 sensor rail will be attached.

[Example of Installation]

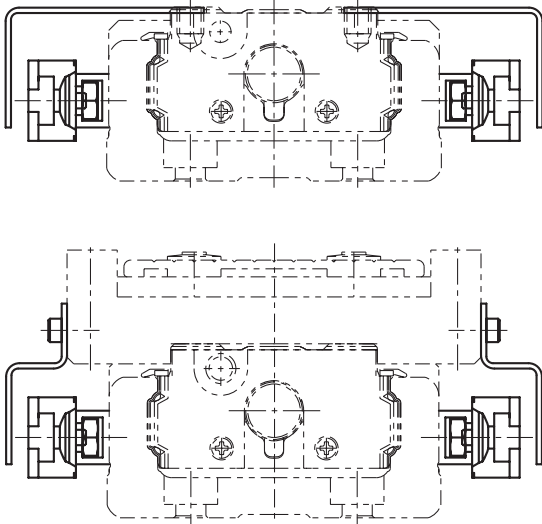

Outer rail length with a sensor/sensor rail mounted on both sides
Unit: mm

Table14 With/without a sensor

Symbol	Description	Type	Accessory
0	None	—	—
1	With sensor rail	—	Mounting screws, sensor rail
2	Photo Sensor* [3 units]	EE-SX671 (Omron Corp.)	Mounting screw/nut, detecting plate, sensor rail, mounting plate, connector (EE-1001)
6	Photo Sensor* [3 units]	EE-SX674 (Omron Corp.)	Mounting screw/nut, detecting plate, sensor rail, mounting plate, connector (EE-1001)
7	Proximity Sensor N.O. contact [3 units]	APM-D3A1-001 (Azbil Corp.)	Mounting screw/nut, detecting plate, sensor rail
B	Proximity Sensor N.C. contact [3 units]	APM-D3B1-003 (Azbil Corp.)	Mounting screw/nut, detecting plate, sensor rail
E	Proximity Sensor N.O. contact [1 unit] N.C. contact [2 units]	APM-D3A1-001 (Azbil Corp.) APM-D3B1-003 (Azbil Corp.)	Mounting screw/nut, detecting plate, sensor rail
H	Proximity Sensor N.O. contact [3 units]	GX-F12A (Panasonic Industrial Devices SUNX Co., Ltd.)	Mounting screw/nut, detecting plate, sensor rail
L	Proximity Sensor N.C. contact [3 units]	GX-F12B (Panasonic Industrial Devices SUNX Co., Ltd.)	Mounting screw/nut, detecting plate, sensor rail
J	Proximity Sensor N.O. contact [1 unit] N.C. contact [2 units]	GX-F12A (Panasonic Industrial Devices SUNX Co., Ltd.) GX-F12B (Panasonic Industrial Devices SUNX Co., Ltd.)	Mounting screw/nut, detecting plate, sensor rail
M	Proximity Sensor N.O. contact [1 unit] N.C. contact [2 units]	GX-F12A-P (Panasonic Industrial Devices SUNX Co., Ltd.) GX-F12B-P (Panasonic Industrial Devices SUNX Co., Ltd.)	Mounting screw/nut, detecting plate, sensor rail

N.O. contact: normally open contact

N.C. contact: normally closed contact

*The photo-sensors can be switched between ON when lit and ON when unlit.

[Proximity Sensor]

APM-D3A1-001 (Azbil Corp.) 3 units
 APM-D3B1-003 (Azbil Corp.) 3 units
 GX-F12A (Panasonic Industrial Devices SUNX Co., Ltd.) 3 units

GX-F12B (Panasonic Industrial Devices SUNX Co., Ltd.) 3 units
 GX-F12A-P (Panasonic Industrial Devices SUNX Co., Ltd.) 3 units
 GX-F12B-P (Panasonic Industrial Devices SUNX Co., Ltd.) 3 units

● Proximity Sensor: APM-D3A1-001 APM-D3B1-003 (Azbil Corp.)

Unit: mm

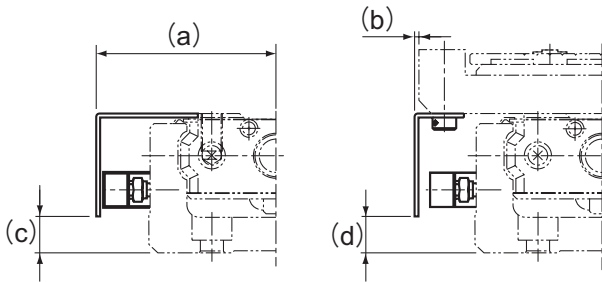

Model No.	a	b	c	d
KR15	27.8	5.8	1.4	1.4
KR20	32.5	6.6	6	6
KR26	37	6.4	8	8
KR30H	43.3	3.3	8.8	9
KR33	42.5	-0.6	8.8	9
KR45H	53.2	1.2	14	14
KR46	55.4	-0.6	21.8	22
KR55	62.4	0.4	22	22
KR65	77.4	-7.6	25.1	25

● Proximity Sensor: GX-F12A GX-F12B GX-F12A-P GX-F12B-P (Panasonic Industrial Devices SUNX Co., Ltd.)

Unit: mm

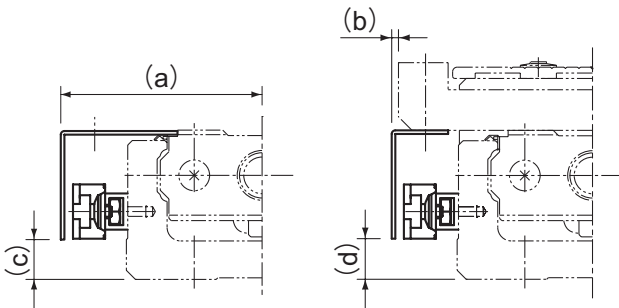

Model No.	a	b	c	d
KR20	34	8.1	3.6	4
KR26	38.5	7.9	6	6
KR30H	45	5	8.8	9
KR33	44.5	1.5	8.8	9
KR45H	54.8	2.8	13.8	14
KR46	57.5	1.5	21.8	22
KR55	64.5	2.5	22	22
KR65	79	-6	25.1	25

[Photo Sensor]

EE-SX671 (Omron Corp.) 3 units

EE-SX674 (Omron Corp.) 3 units

Connector EE-1001 (Omron Corp.) 3 units

Note) The connector is an appended article.

● **Photo Sensor: EE-SX671 (Omron Corp.)**

Unit: mm

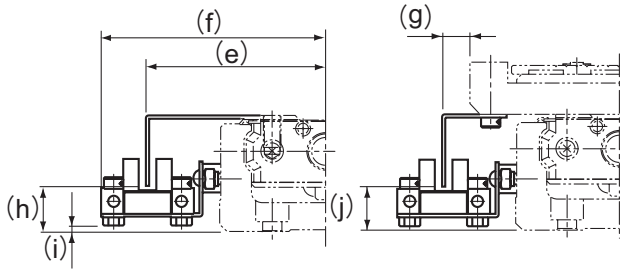

Model No.	e	f	g	h	i	j
KR20	41.3	53.8	15	9.4	0.9	9.5
KR26	46	58.7	14.9	11.4	2.9	11.5
KR30H	51.3	63.9	11.3	13.8	1.4	13.5
KR33	50.8	63.7	7.7	12.8	2.2	13
KR45H	61.2	73.8	9.3	18.3	6.4	18.5
KR46	63.6	76.6	7.7	25.8	15.2	26
KR55	70.7	83.5	8.6	24.5	13.6	25
KR65	85.5	98.5	0.6	28.1	16.6	28

● **Photo Sensor: EE-SX674 (Omron Corp.)**

Unit: mm

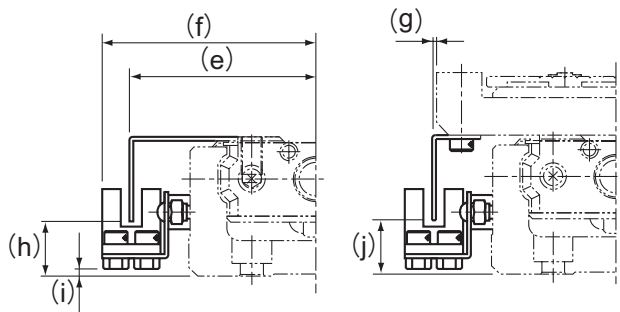

Model No.	e	f	g	h	i	j
KR20	38.3	44.8	12.5	10.9	0.6	11
KR26	43.5	49.7	12.5	12.9	2.6	13
KR30H	46.2	52.4	6.3	13.8	1.1	14
KR33	44.5	50.7	1.5	12.8	1.7	13
KR45H	56.2	62.3	4.2	19	6.1	19
KR46	57.5	63.6	1.5	25.8	14.1	26
KR55	63.5	70.5	1.5	24.5	13.1	24
KR65	79	85.5	-6	28.6	16.1	28

[Sensor Rail]

The sensor rail can be attached alone.

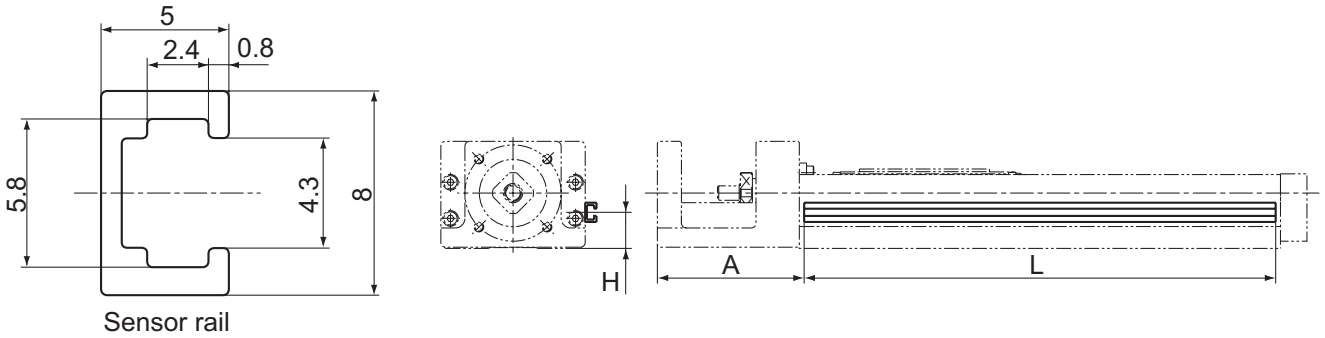

Unit: mm

Model No.	Stroke*	Outer rail length	H	A	L
KR15	25	75	5.5	37.5	88
	50	100			113
	75	125			138
	100	150			163
	125	175			188
	150	200			213
KR20	30	100	10	43	111
	80	150			161
	130	200			211
KR26	60	150	12	54	161
	110	200			211
	160	250			261
	210	300			311
KR30H	50	150	14	61	146
	100	200			196
	200	300			296
	300	400			396
	400	500			496
KR33	500	600	15	61	596
	600	700			696
	200	300			296
	300	400			396
	400	500			496
	500	600			596
KR45H	200	340	19	90	336
	300	440			436
	400	540			536
	500	640			636
	600	740			736
	700	840			836
	800	940			936

Unit: mm

Model No.	Stroke*	Outer rail length	H	A	L
KR46	190	340	28	89.5	336
	290	440			436
	390	540			536
	490	640			636
	590	740			736
	690	840			836
	790	940			936
KR55	800	980	27	96	976
	900	1080			1076
	1000	1180			1176
	1100	1280			1276
KR65	1200	1380	30	102	1376
	790	980			976
	990	1180			1176
	1190	1380			1376
	1490	1680			1676

Housing

[Housing A]

THK also offers Housing A provided with a separate motor, and a turnaround type of Housing A, as options in order to support a motor bracket or a turnaround section that the customer may separately produce.

[Housing A for a Separate Motor]

By using the fitting difference, the user can easily mount a separately manufactured motor bracket.

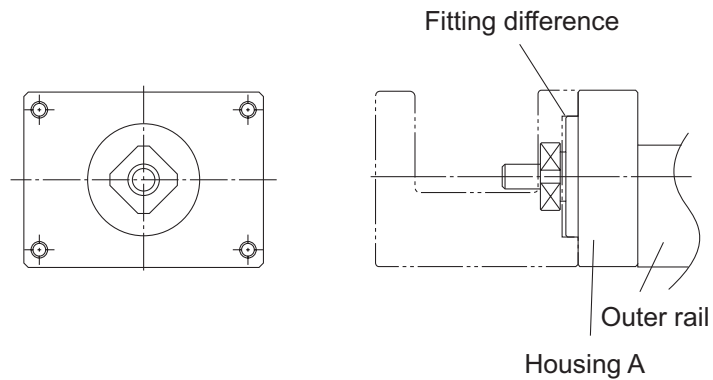

[Turnaround Housing A]

Since the mounting holes are drilled in constant pitch, the user can select the motor bracket orientation.

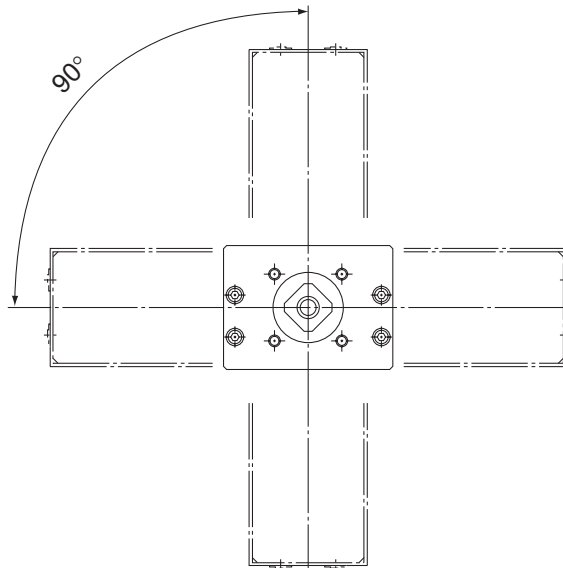

Intermediate Flange

[Motor Used and Applicable Intermediate Flanges for Model KR]

Several types of intermediate flanges for mounting motors are available for model KR. Specify an intermediate flange that matches the motor used.

Table15 Table of Motors Used and Corresponding Intermediate Flanges

Motor type		Rated output	Dimension angle	KR15	KR20	KR26	KR30H	KR33	KR45H	KR46	KR55	KR65		
AC servomotor	Yaskawa Electric	Σ-mini	SGMM-A1	10W	□25	AN	AN	AN	—	—	—	—		
			SGMM-A2	20W		AN	AN	AN	—	—	—	—	—	
			SGMM-A3	30W		—	AN	AN	—	—	—	—	—	
		Σ-V	SGMJV-A5	50W	□40	—	AQ	AQ	AQ	AQ	AQ	AQ	—	—
						—	AQ	AQ	AQ	AQ	AQ	AQ	—	—
			SGMAV-A5	100W	□40	—	—	—	AQ	AQ	AQ	AQ	—	—
						—	—	—	AQ	AQ	AQ	AQ	—	—
			SGMJV-01	150W	□40	—	—	—	—	—	AQ	AQ	—	—
						—	—	—	—	—	AQ	AQ	—	—
			SGMAV-01	200W	□60	—	—	—	—	—	A0	40	A0	AV
						—	—	—	—	—	A0	40	A0	AV
			SGMJV-02	400W	□60	—	—	—	—	—	A0	40	A0	AV
	—					—	—	—	—	A0	40	A0	AV	
	SGMAV-02	550W	□60	—	—	—	—	—	—	—	—	A0	AV	
				—	—	—	—	—	—	—	—	A0	AV	
	SGMJV-04	750W	□80	—	—	—	—	—	—	—	—	AZ	AZ	
				—	—	—	—	—	—	—	—	AZ	AZ	
	Σ-III	SGMAS-A5	50W	□40	—	AQ	AQ	AQ	AQ	AQ	AQ	—	—	
					—	—	—	AQ	AQ	AQ	AQ	—	—	
		SGMAS-01	100W	□60	—	—	—	—	—	A0	40	A0	AV	
					—	—	—	—	—	A0	40	A0	AV	
		SGMPS-01	200W	□60	—	—	—	—	—	A0	40	A0	AV	
					—	—	—	—	—	A0	40	A0	AV	
		SGMAS-02	400W	□80	—	—	—	—	—	—	—	AZ	A0	
					—	—	—	—	—	—	—	AZ	A0	
	SGMPS-02	400W	□80	—	—	—	—	—	—	—	—	AZ	A0	
				—	—	—	—	—	—	—	AZ	A0		
	Σ-II	SGMAH-A3	30W	□40	—	AQ	AQ	AQ	AQ	AQ	AQ	—	—	
					—	AQ	AQ	AQ	AQ	AQ	AQ	—	—	
		SGMAH-A5	50W	□40	—	—	—	AQ	AQ	AQ	AQ	—	—	
					—	—	—	AQ	AQ	AQ	AQ	—	—	
		SGMPH-01	100W	□60	—	—	—	—	—	A0	40	A0	AV	
					—	—	—	—	—	A0	40	A0	AV	
		SGMAH-02	200W	□60	—	—	—	—	—	A0	40	A0	AV	
					—	—	—	—	—	A0	40	A0	AV	
	SGMAH-04	400W	□80	—	—	—	—	—	—	—	—	AZ	A0	
				—	—	—	—	—	—	—	—	AZ	A0	
	SGMPH-02	200W	□80	—	—	—	—	—	—	—	—	AZ	A0	
				—	—	—	—	—	—	—	—	AZ	A0	
	SGMPH-04	400W	□80	—	—	—	—	—	—	—	—	AZ	A0	
—				—	—	—	—	—	—	—	AZ	A0		
SGMAH-08	750W	□80	—	—	—	—	—	—	—	—	AZ	AZ		
			—	—	—	—	—	—	—	—	AZ	AZ		
Mitsubishi Electric	MELSERVO	J2-Jr	HC-AQ013	10W	□28	AM	AM	AM	—	—	—	—		
			HC-AQ023	20W		AM	AM	AM	—	—	—	—		
			HC-AQ033	30W		—	AM	AM	—	—	—	—		
		J3	HF-MP053	50W	□40	—	AQ	AQ	AQ	AQ	AQ	AQ	—	—
						—	AQ	AQ	AQ	AQ	AQ	AQ	—	—
			HF-KP053	100W	□40	—	—	—	AQ	AQ	AQ	AQ	—	—
						—	—	—	AQ	AQ	AQ	AQ	—	—
			HF-MP13	200W	□60	—	—	—	—	—	A0	40	A0	AV
						—	—	—	—	—	A0	40	A0	AV
		HF-KP13	400W	□60	—	—	—	—	—	A0	40	A0	AV	
					—	—	—	—	—	A0	40	A0	AV	
		HF-MP43	750W	□80	—	—	—	—	—	—	—	—	AZ	AZ
					—	—	—	—	—	—	—	—	AZ	AZ
		J2 Super	HC-MFS053	50W	□40	—	AQ	AQ	AQ	AQ	AQ	AQ	—	—
						—	AQ	AQ	AQ	AQ	AQ	AQ	—	—
			HC-KFS053	100W	□40	—	—	—	AQ	AQ	AQ	AQ	—	—
						—	—	—	AQ	AQ	AQ	AQ	—	—
			HC-MFS13	200W	□60	—	—	—	—	—	A0	40	A0	AV
	—					—	—	—	—	A0	40	A0	AV	
	HC-KFS13		400W	□60	—	—	—	—	—	A0	40	A0	AV	
					—	—	—	—	—	A0	40	A0	AV	
	HC-MFS23		750W	□80	—	—	—	—	—	—	—	—	AZ	AZ
					—	—	—	—	—	—	—	—	AZ	AZ
	HC-KFS23		400W	□60	—	—	—	—	—	A0	40	A0	AV	
					—	—	—	—	—	A0	40	A0	AV	
	HC-MFS43	750W	□80	—	—	—	—	—	—	—	—	AZ	AZ	
				—	—	—	—	—	—	—	—	AZ	AZ	
	HC-KFS43	400W	□60	—	—	—	—	—	A0	40	A0	AV		
				—	—	—	—	—	A0	40	A0	AV		
	HC-MFS73	750W	□80	—	—	—	—	—	—	—	—	AZ	AZ	
—				—	—	—	—	—	—	—	AZ	AZ		
HC-KFS73	750W	□80	—	—	—	—	—	—	—	—	AZ	AZ		
			—	—	—	—	—	—	—	—	AZ	AZ		

		Motor type	Rated output	Dimension angle	KR15	KR20	KR26	KR30H	KR33	KR45H	KR46	KR55	KR65				
AC servomotor	Panasonic Corp.	MINAS	A4	MSMD5A	50W	□38	—	AP	AP	AP	AP	AP	—	—			
				MSMD01	100W	□38	—	—	—	AP	AP	AP	AP	—	—		
				MQMA01			200W	□60	—	—	—	—	—	AY	30	—	—
				MSMD02	400W	□60			—	—	—	—	—	AY	30	—	—
				MAMA02					750W	□80	—	—	—	—	—	AY	30
				MSMD04	400W	□80	—	—			—	—	—	AY	30	—	—
				MAMA04			750W	□80	—	—	—	—	—	AY	30	—	—
			MSMD08	750W	□80	—			—	—	—	—	—	—	A5	A5	
			MAMA08			750W	□80	—	—	—	—	—	—	—	A5	A5	
			MSMA3A	30W	□38			—	AP	AP	AP	AP	AP	AP	AP	—	—
			MSMA5A	50W		□38	—	AP	AP	AP	AP	AP	AP	AP	—	—	
			MSMA01	100W	□60		—	—	—	AP	AP	AP	AP	AP	—	—	
			MSMA02	200W		□60	—	—	—	—	—	AY	30	—	—	—	
			MAMA02		400W		□60	—	—	—	—	—	AY	30	—	—	—
		MSMA04	400W	□60		—		—	—	—	—	AY	30	—	—	—	
		MAMA04			750W	□80	—	—	—	—	—	AY	30	—	—	—	
		MSMA08	750W	□80			—	—	—	—	—	—	—	A5	A5		
		MAMA08			750W	□80	—	—	—	—	—	—	—	A5	A5		
		MUMA02	200W	□60			—	—	—	—	—	AY	30	—	—		
		MUMA04	400W		□60	—	—	—	—	—	AY	30	—	—			
		SANYO Electric	SANMOTION	Q1		Q1AA04003D	30W	□40	—	AQ	AQ	AQ	AQ	AQ	AQ	—	—
					Q1AA04005D	50W	—		AQ	AQ	AQ	AQ	AQ	AQ	AQ	—	—
					Q1AA04010D	100W	□60	—	—	—	AQ	AQ	AQ	AQ	—	—	
					Q1AA06020D	200W		—	—	—	—	—	A0	40	A0	AV	
					Q1AA06040D	400W	□76	—	—	—	—	—	A0	40	A0	AV	
					Q1AA07075D	750W		—	—	—	—	—	—	—	A5	A5	
				Omron	OMNUC G5	R88M-K05030	50W	□40	—	AQ	AQ	AQ	AQ	AQ	AQ	—	—
						R88M-K10030	100W		—	—	—	AQ	AQ	AQ	AQ	—	—
						R88M-K20030	200W	□60	—	—	—	—	—	AY	30	—	—
						R88M-K40030	400W		—	—	—	—	—	AY	30	—	—
		R88M-K75030	750W			□80	—	—	—	—	—	—	—	A5	A5		
		OMNUC G	R88M-G05030		50W	□40	—	AQ	AQ	AQ	AQ	AQ	AQ	AQ	—	—	
			R88M-G10030		100W		—	—	—	AQ	AQ	AQ	AQ	AQ	—	—	
			R88M-GP10030		200W	□60	—	—	—	—	—	AY	30	—	—		
	R88M-G20030		400W				—	—	—	—	AY	30	—	—			
	R88M-G40030		400W		□80	—	—	—	—	—	AY	30	—	—			
	R88M-GP20030	200W	—	—		—	—	—	—	—	—	—					
	R88M-GP40030	400W	—	—		—	—	—	—	—	—	—					
	R88M-G75030	750W	□80	—	—	—	—	—	—	—	—	A5	A5				
	Fanuc	βis series	βis0.2/5000	50W	□40	—	AQ	AQ	AQ	AQ	AQ	AQ	—	—			
			βis0.3/5000	100W		—	—	—	AQ	AQ	AQ	AQ	—	—			
			βis0.4/5000	130W	□60	—	—	—	—	—	A0	40	A0	AV			
			βis0.5/6000	350W		—	—	—	—	—	A0	40	A0	AV			
			βis1/6000	500W	□60	—	—	—	—	—	A0	40	A0	AV			
Keyence Corporation	MV	MV-M05	50W	□40	—	AQ	AQ	AQ	AQ	AQ	AQ	—	—				
		MV-M10	100W		—	—	—	AQ	AQ	AQ	AQ	—	—				
		MV-M20	200W	□60	—	—	—	—	—	A0	40	A0	AV				
		MV-M40	400W		—	—	—	—	—	A0	40	A0	AV				
		MV-M75	750W	□76	—	—	—	—	—	—	—	—	A5	A5			
Stepping motor	Oriental Motor	αStep	ASC3 *	□28	AS	AS	AS	—	—	—	—	—	—				
			AS46, ASC46, AR46	□42	—	AR	AR	AR	AR	—	—	—	—				
			AS6 *, ASC66, AR6 *	□60	—	—	—	AU	AU	AU	10	—	—				
			AS9 *	□85	—	—	—	—	—	—	—	A6	A6				
		5 phase	CSK II	CSK52 *	□28	AS	AS	AS	—	—	—	—	—	—			
				CSK54 *	□42	—	AR	AR	AR	AR	—	—	—	—			
				CSK56 *	□60	—	—	—	AU	AU	AU	10	—	—			
			CSK59 *	□85	—	—	—	—	—	—	—	—	A6	A6			
			RK	RK54 *	□42	—	AR	AR	AR	AR	—	—	—	—	—		
		RK56 *		□60	—	—	—	AU	AU	AU	10	—	—				
		RK59 *	□85	—	—	—	—	—	—	—	—	A6	A6				
		2 phase	UMK	UMK24 *	□42	—	AR	AR	AR	AR	—	—	—	—			
				UMK26 *	□56.4	—	—	—	AT	AT	—	—	—	—			
			CSK	CSK24 *	□42	—	AR	AR	AR	AR	—	—	—	—			
CSK26 *	□56.4	—	—	—	AT	AT	—	—	—	—	—						

Note1) The symbols in the table indicate the housing A and intermediate flange.

Note2) For motor coupling, contact THK.

Note3) Model KR15 has a limit in input torque. The permissible input torque for model KR1501 is 0.051 N-m at a maximum and that for model KR1502 is 0.103 N-m at a maximum. If the maximum torque of the motor mounted to model KR15 exceeds the permissible input torque, take a safety measure such as setting a torque limit.

[Dimensional Drawing of Housing A/Intermediate Flange for Model KR]

● For Model KR15

KR**	··· Actuator model number
●◇	···●: Housing A ◇: Intermediate Flange

■ Housing A

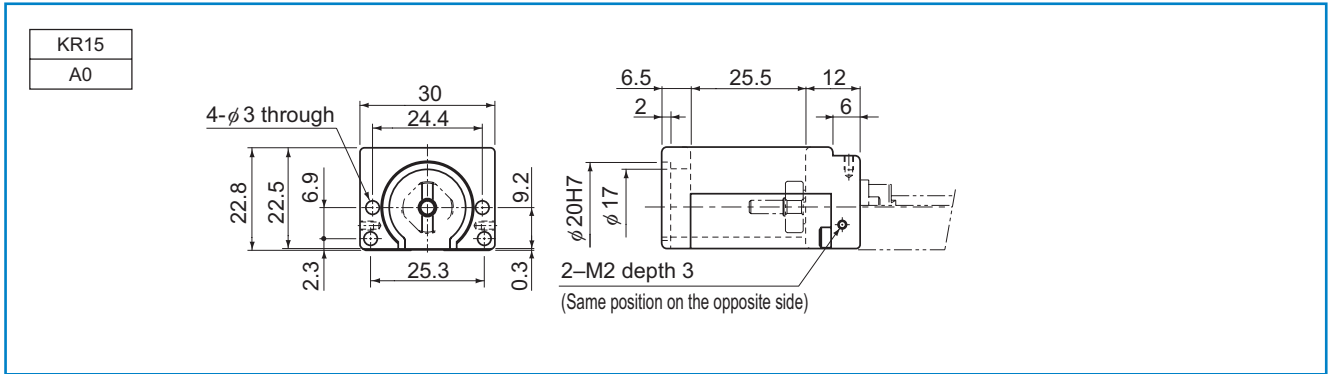

■ Intermediate Flange

Each intermediate flange is made of steel and provided with THK AP-C treatment, a surface treatment for corrosion resistance.

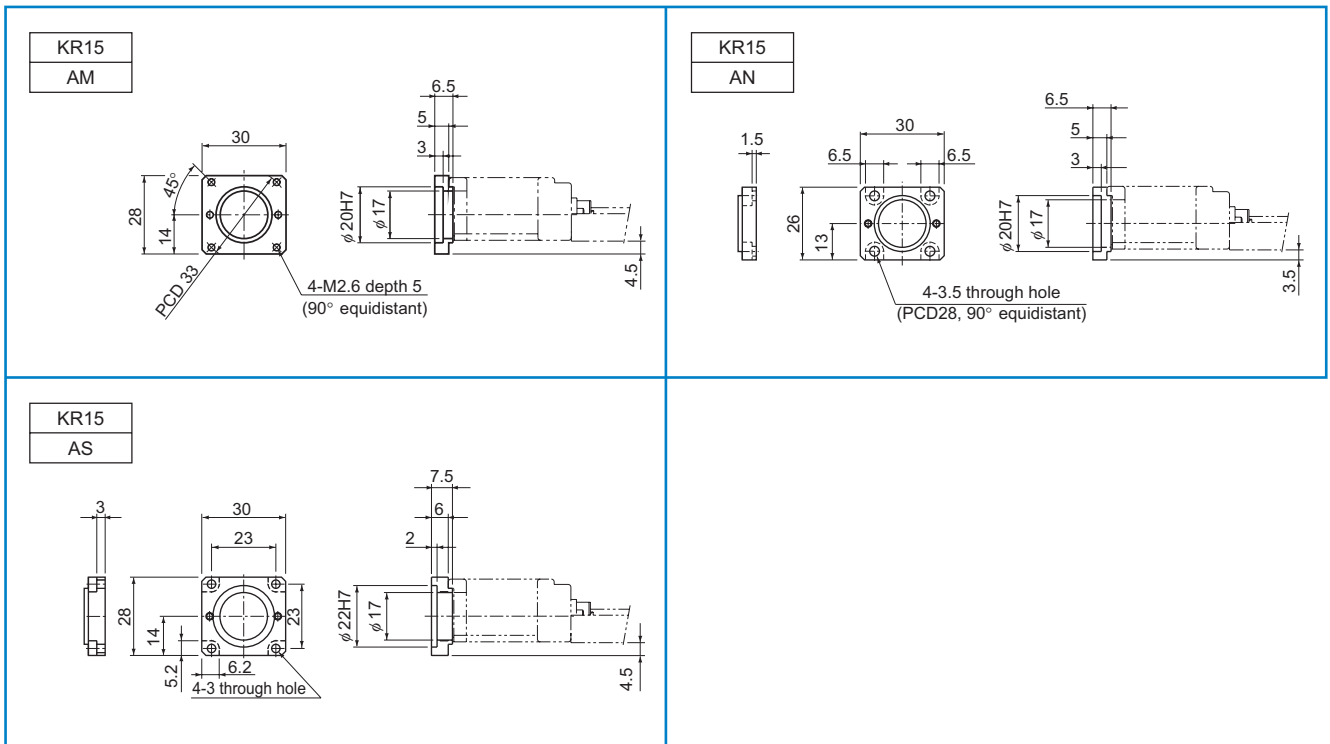

● For Model KR20

KR**	···· Actuator model number
●	···· Housing A
◇	◇ Intermediate Flange

■ Housing A

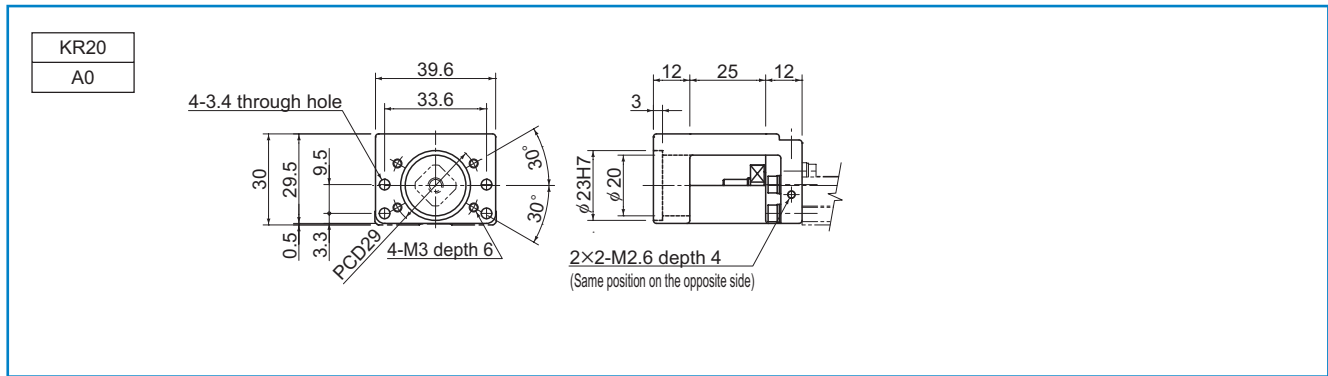

■ Intermediate Flange

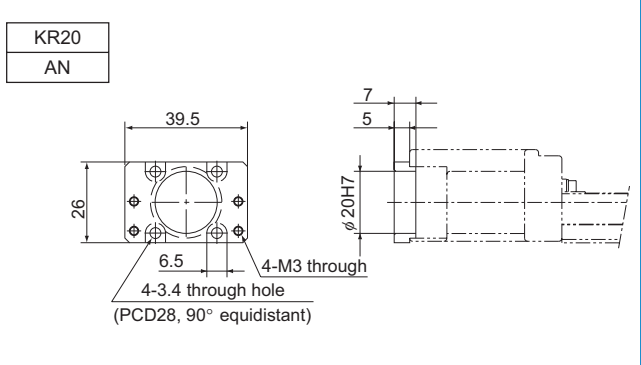
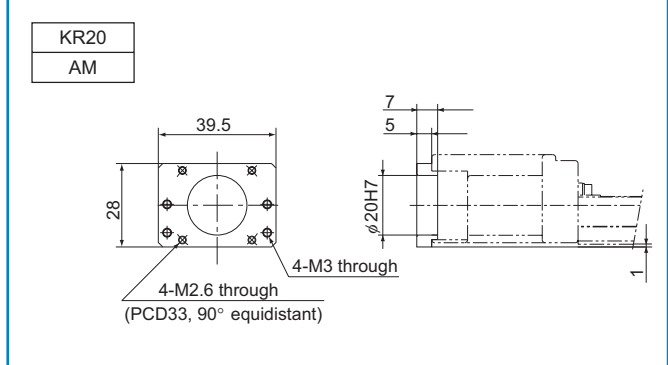
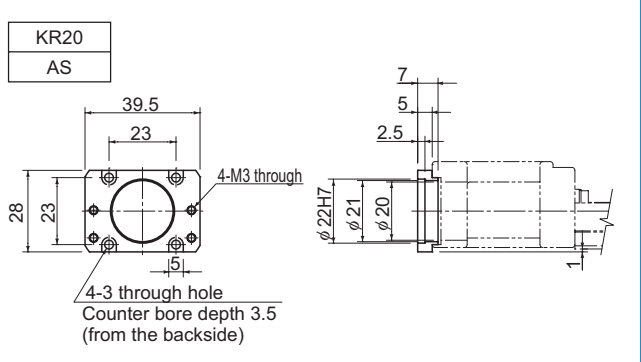
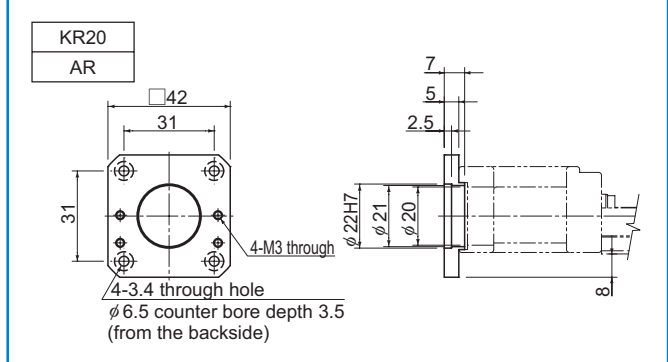
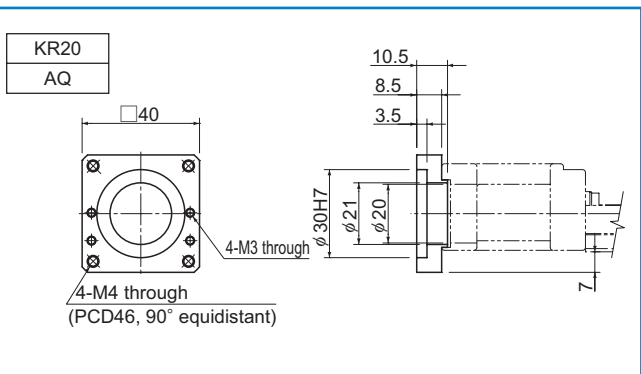
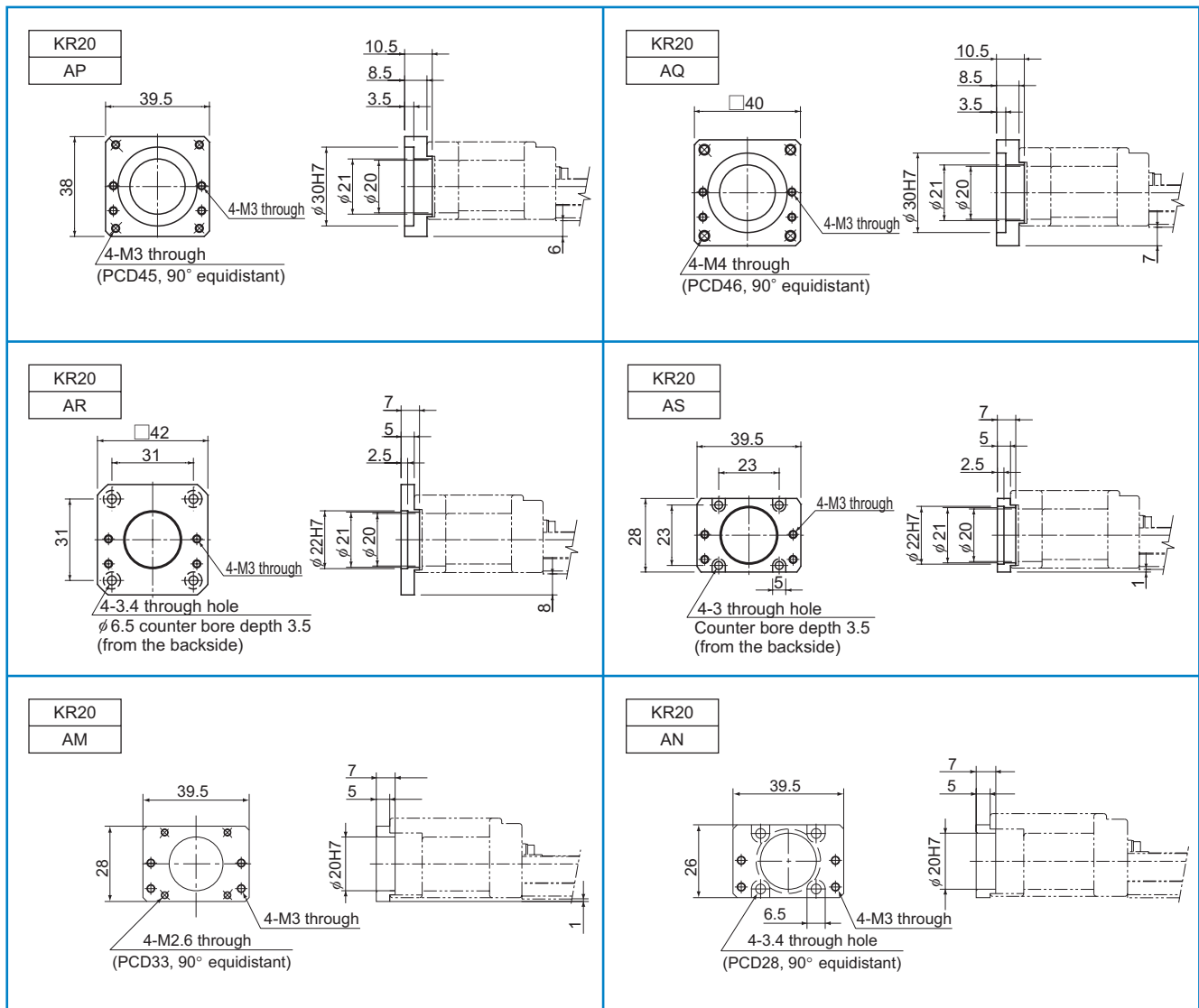

● For Model KR26

KR**	··· Actuator model number
●◇	···●: Housing A ◇: Intermediate Flange

■ Housing A

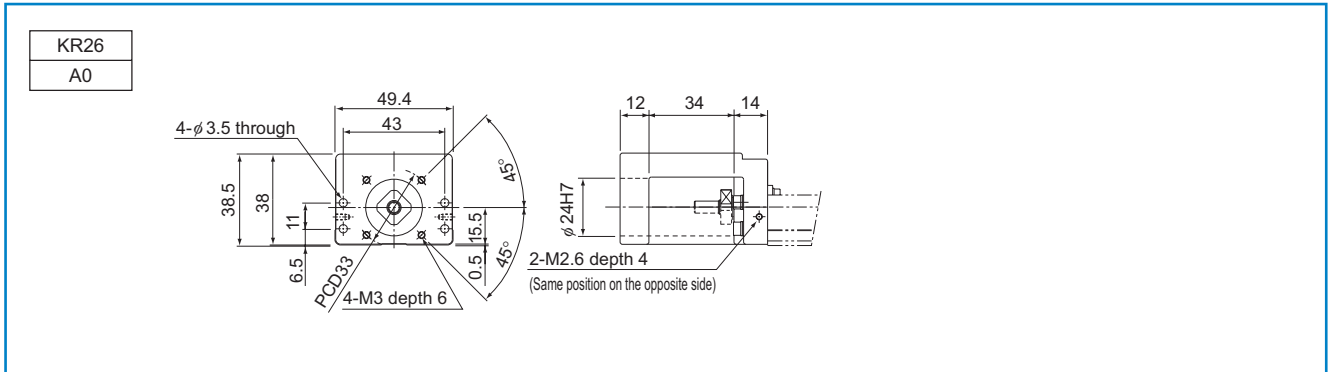

■ Intermediate Flange

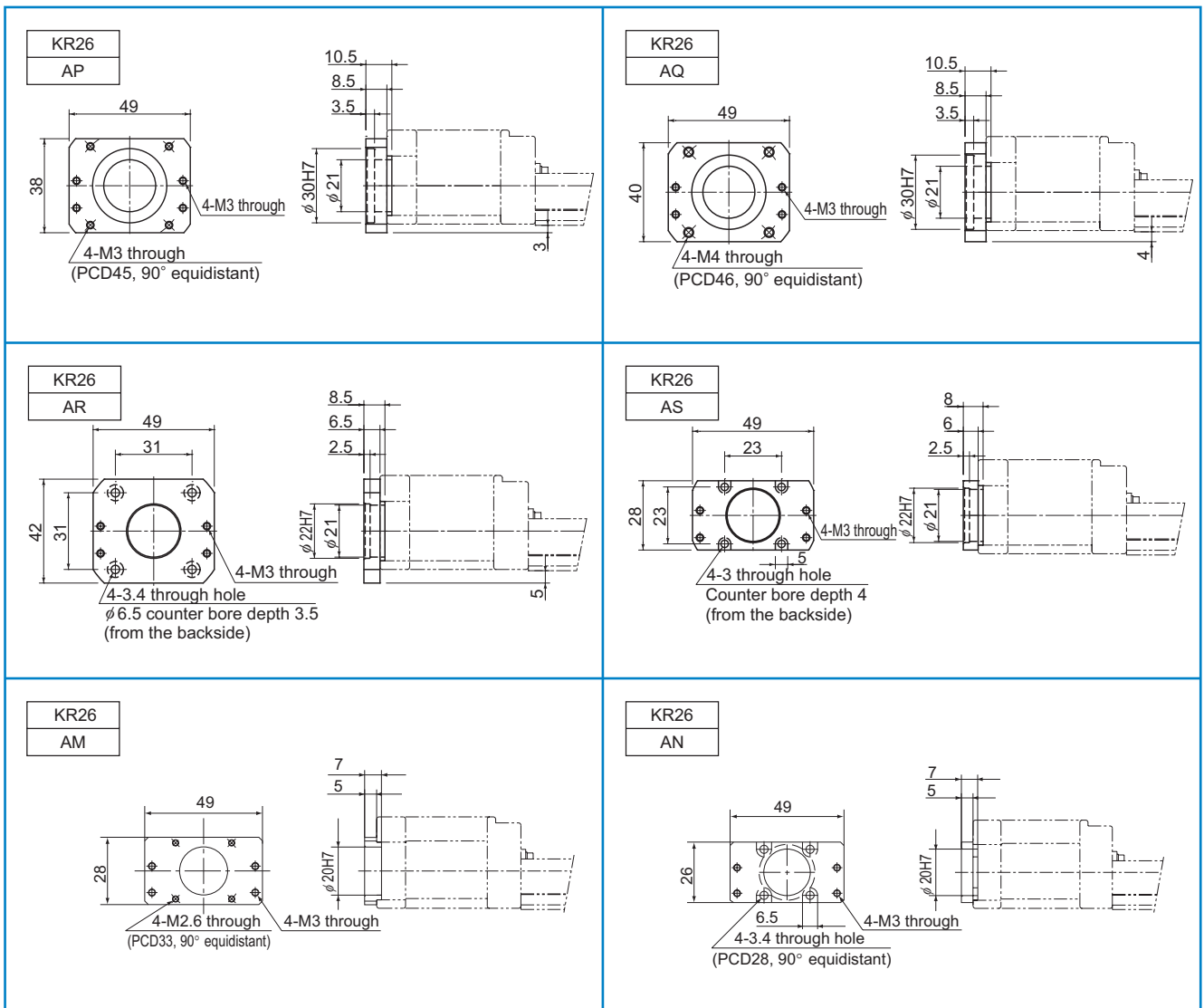

● For Model KR30H

KR**	··· Actuator model number
●	··· Housing A
◇	◇ Intermediate Flange

■ Housing A

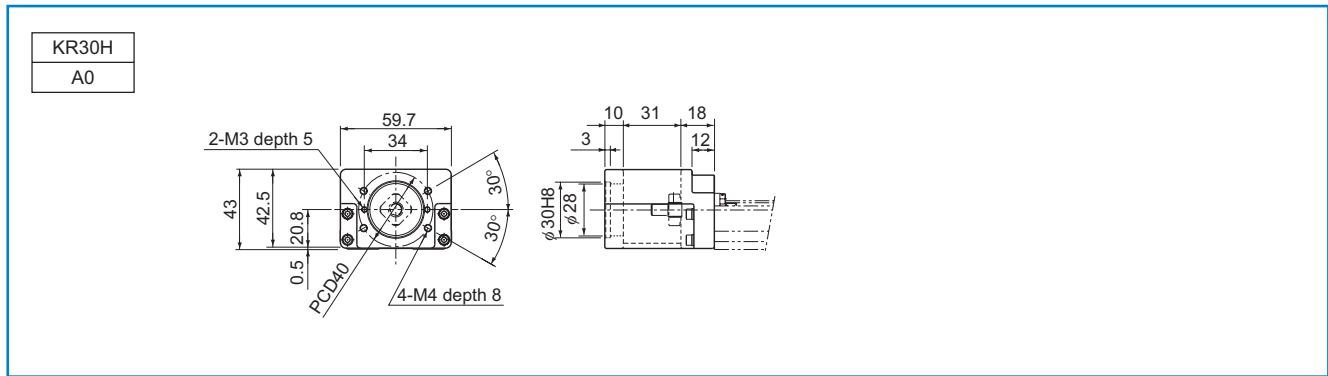

■ Intermediate Flange

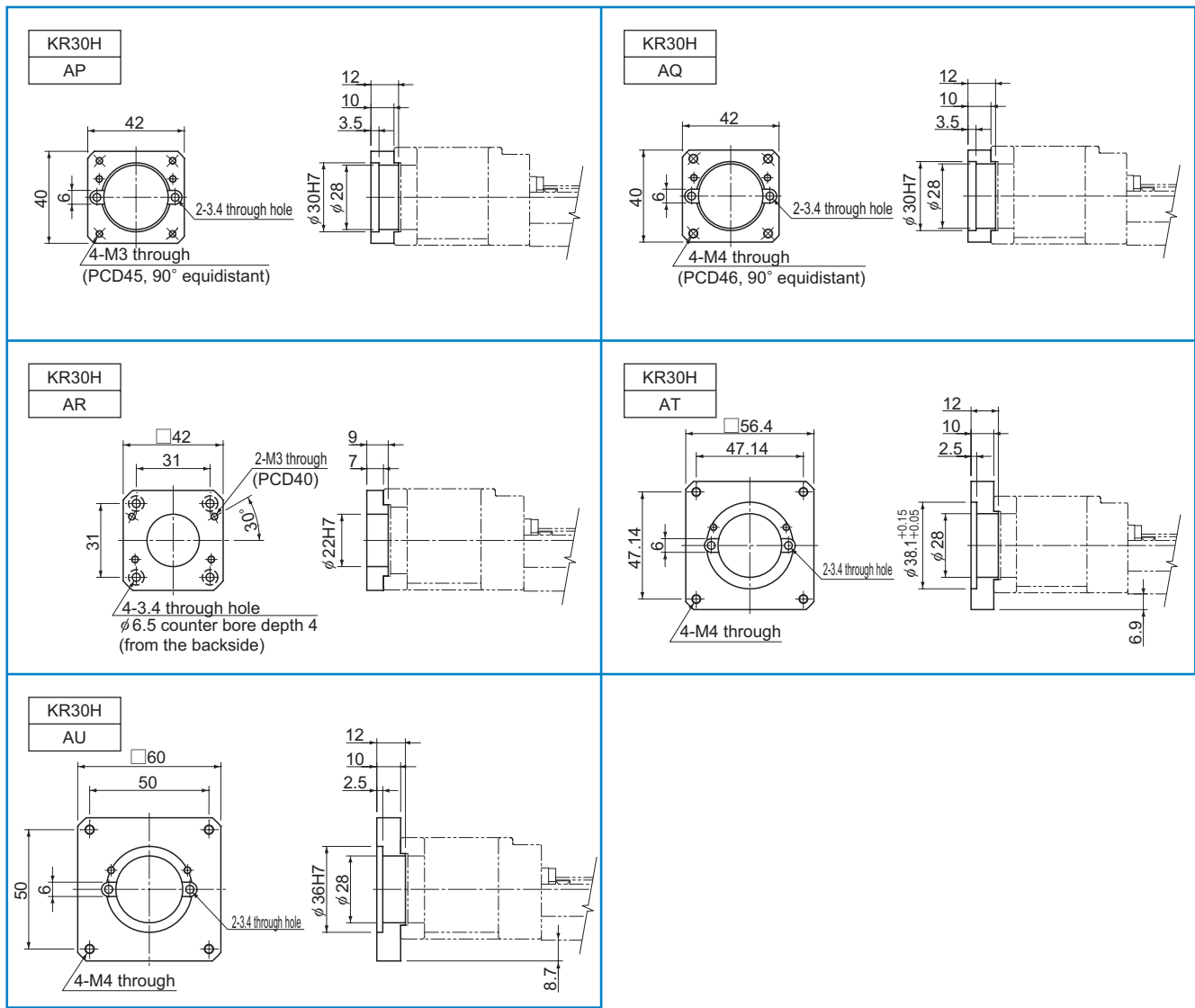

● For Model KR33

KR**	··· Actuator model number
●◇	··· ●: Housing A ◇: Intermediate Flange

■ Housing A

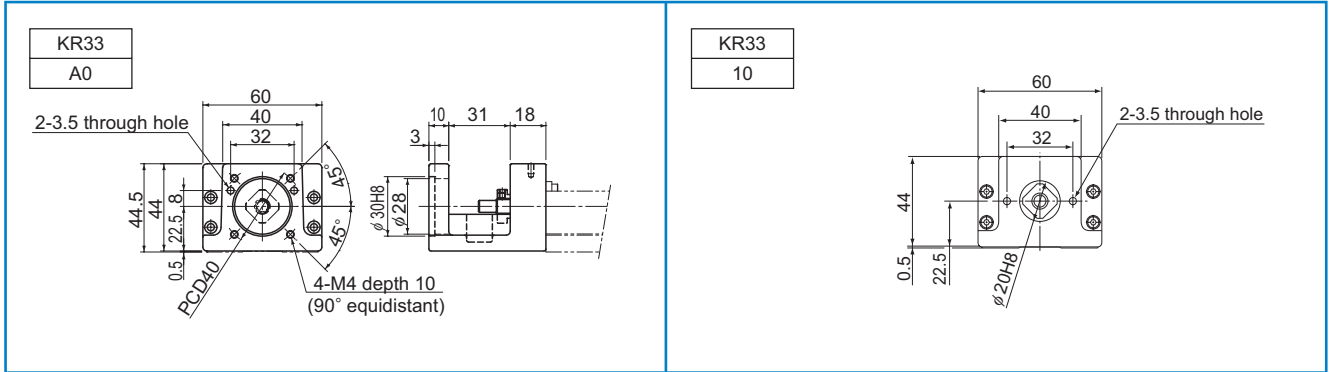

■ Housing A for a Separate Motor

■ Turnaround Housing A

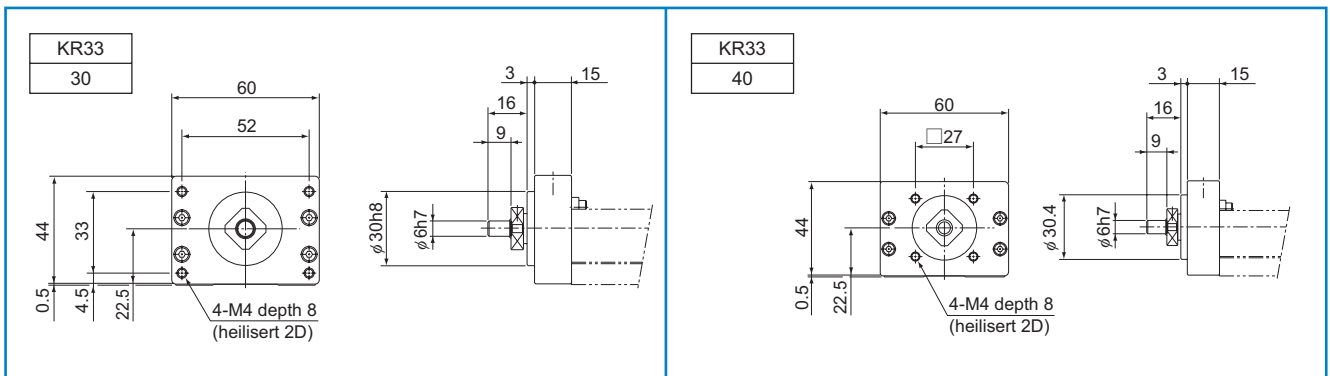

Intermediate Flange

Each intermediate flange is made of steel and provided with THK AP-C treatment, a surface treatment for corrosion resistance.

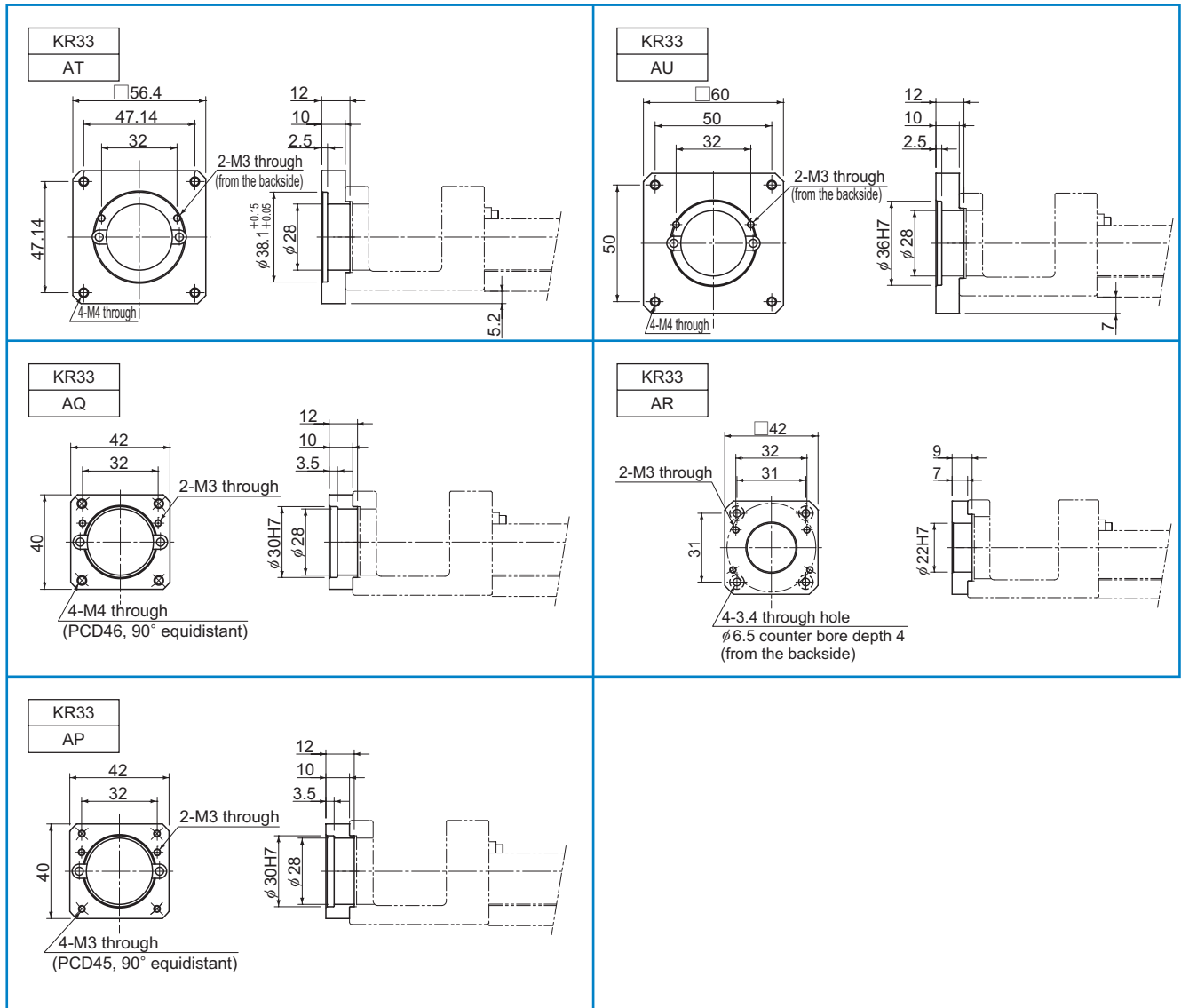

● For Model KR45H

KR**	··· Actuator model number
●◇	···●: Housing A ◇: Intermediate Flange

■ Housing A

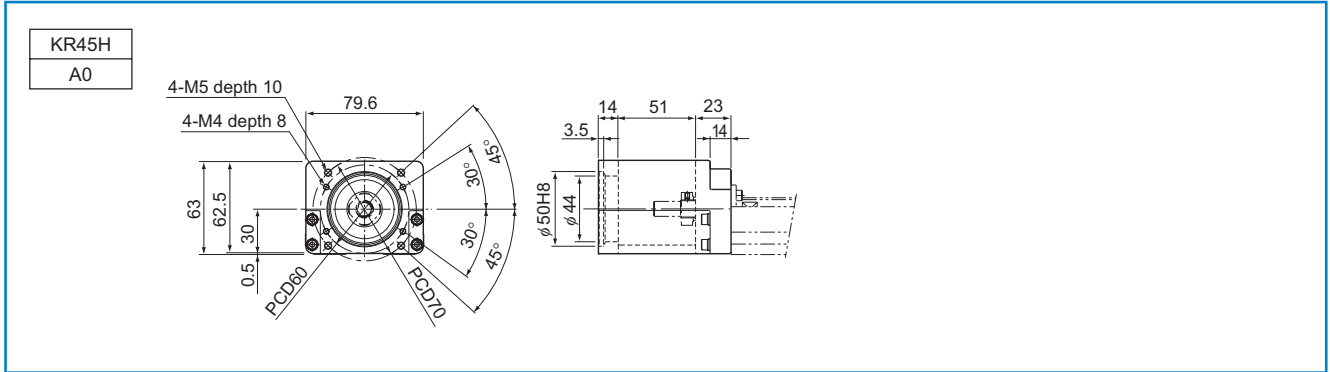

■ Intermediate Flange

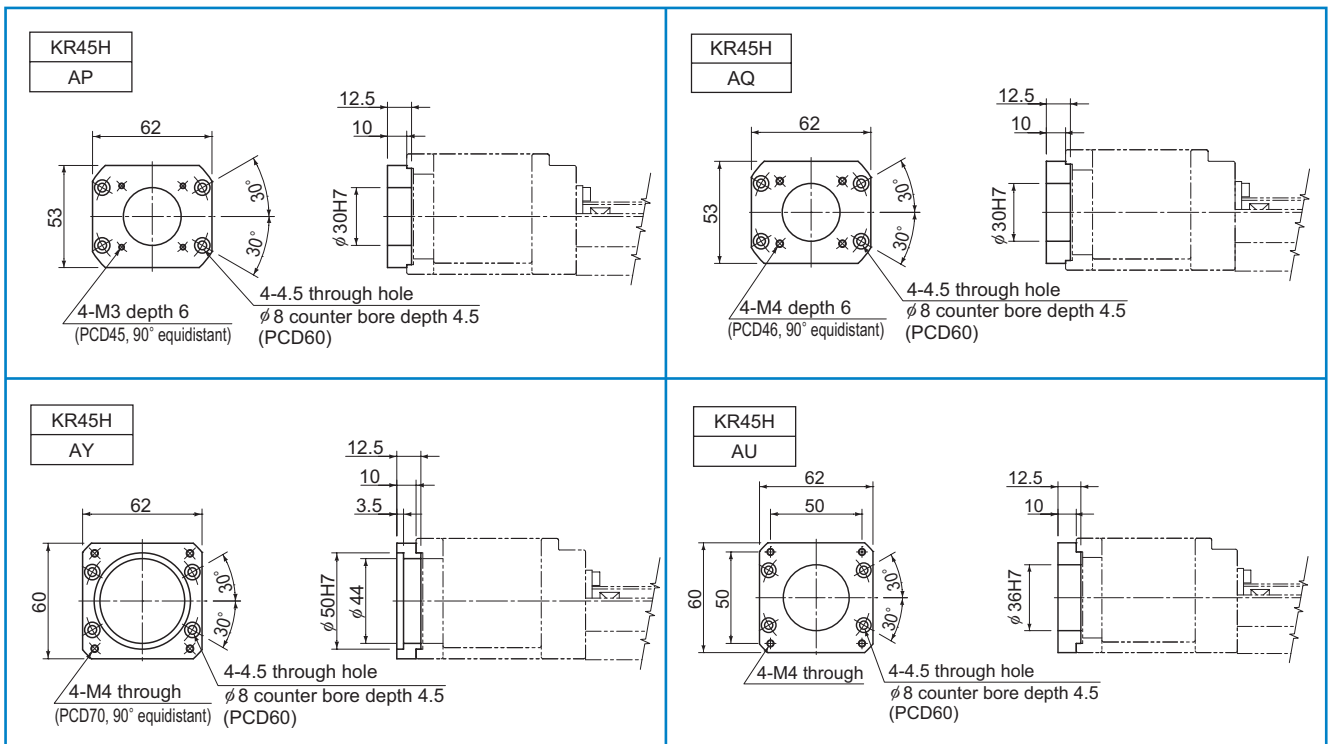

● For Model KR46

KR**	···· Actuator model number
● ◇	····●: Housing A ◇: Intermediate Flange

■ Housing A

<table border="1"> <tr><td>KR46</td></tr> <tr><td>A0</td></tr> </table> <p>4-M4 depth 8 (90° equidistant) 4-M4 depth 8</p>	KR46	A0	<table border="1"> <tr><td>KR46</td></tr> <tr><td>10</td></tr> </table>	KR46	10
KR46					
A0					
KR46					
10					
<table border="1"> <tr><td>KR46</td></tr> <tr><td>20</td></tr> </table>	KR46	20	<table border="1"> <tr><td>KR46</td></tr> <tr><td>30</td></tr> </table>	KR46	30
KR46					
20					
KR46					
30					
<table border="1"> <tr><td>KR46</td></tr> <tr><td>40</td></tr> </table>	KR46	40			
KR46					
40					

■ Housing A for a Separate Motor

KR46
50

4-M5 depth 10 (heilsert 2D)

■ Turnaround Housing A

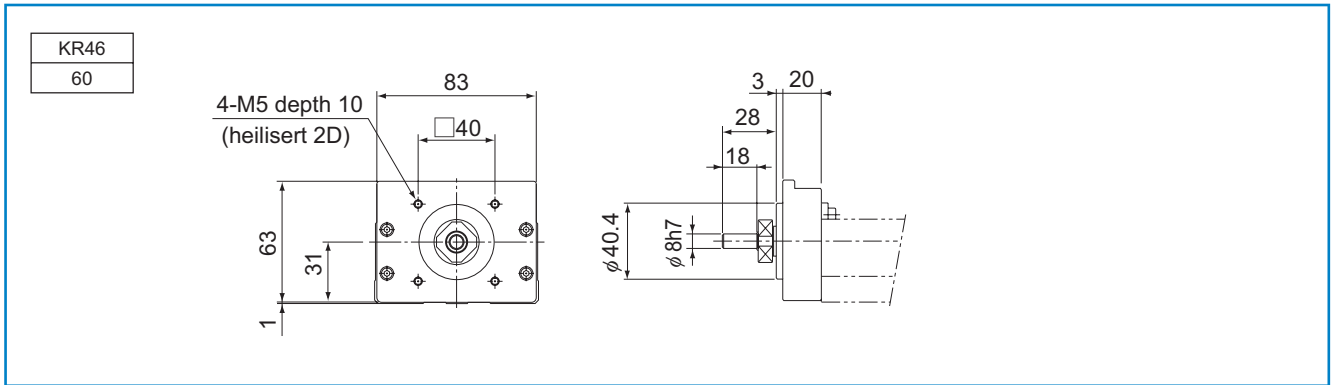

■ Intermediate Flange

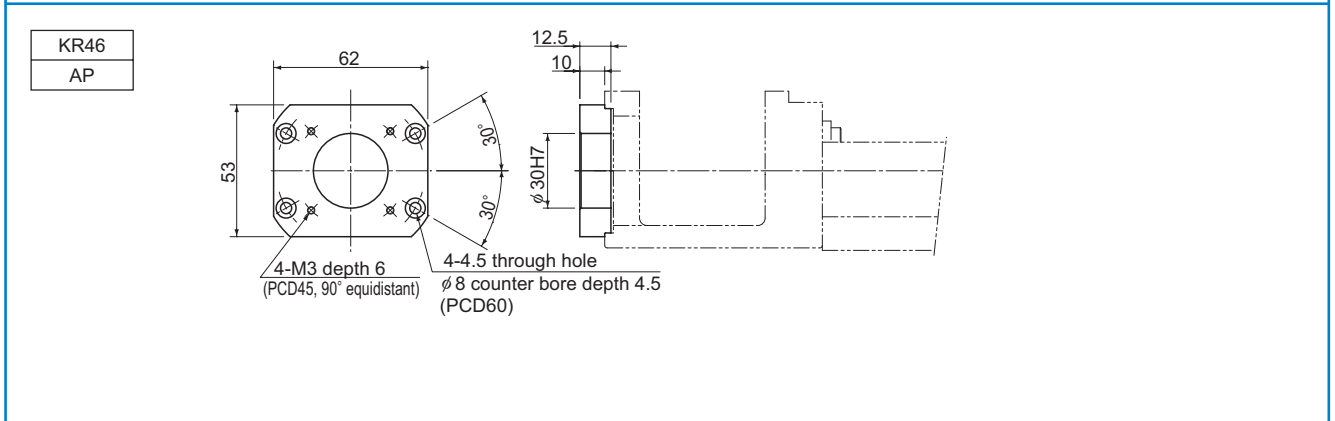
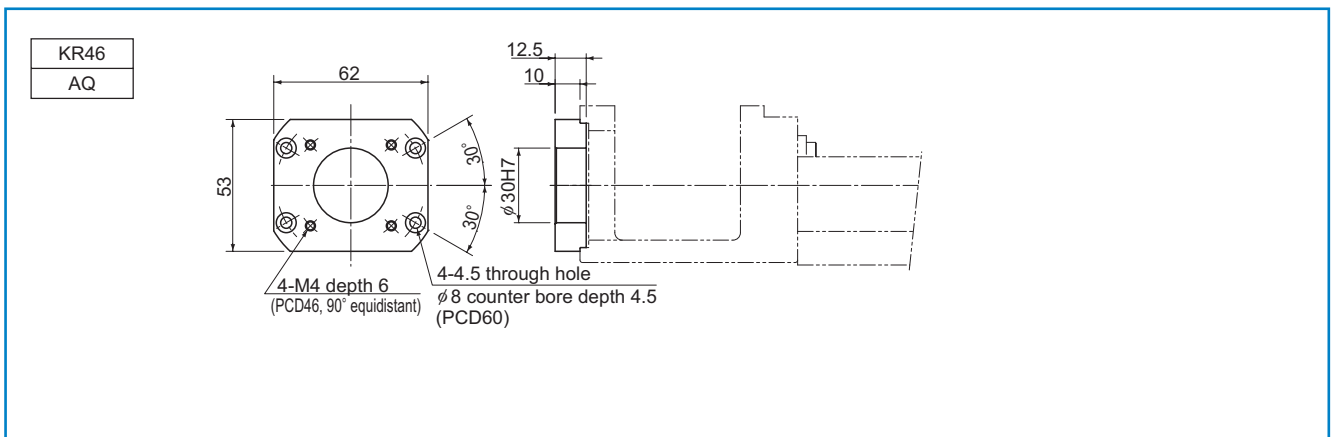

● For Model KR55

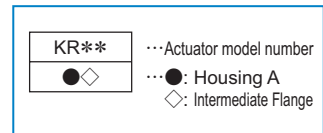

■ Housing A

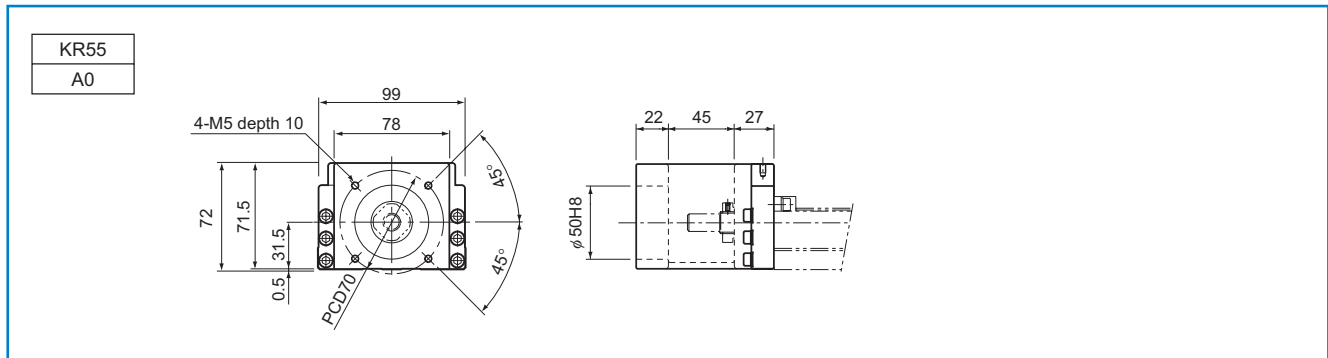

■ Turnaround Housing A

Note) Specify mounting holes when ordering.

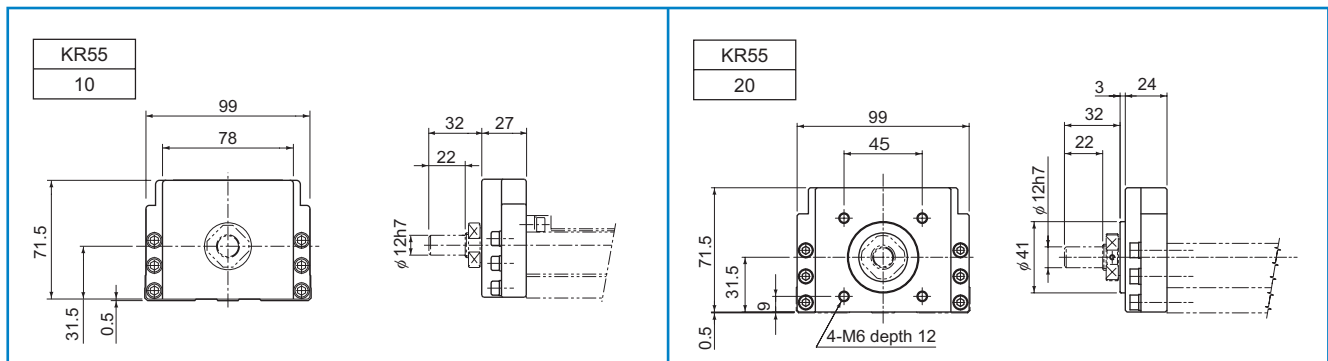

■ Intermediate Flange

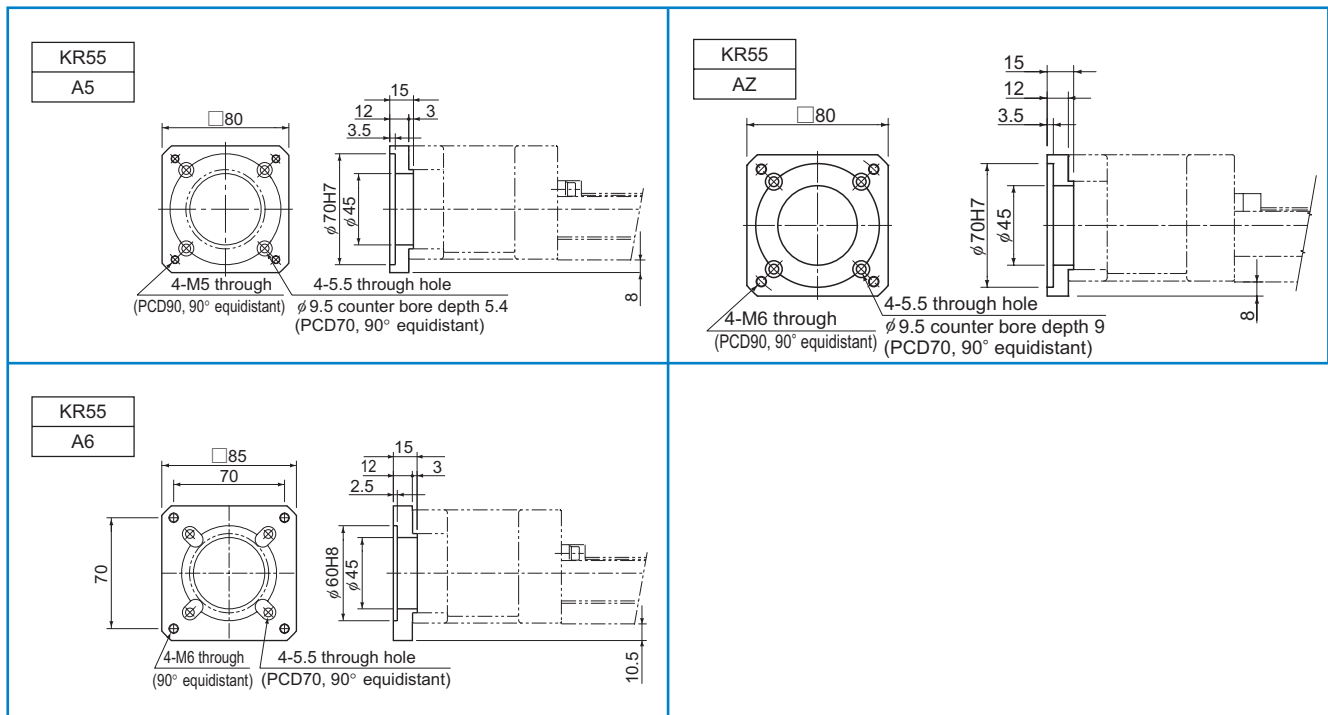

● For Model KR65

KR**	··· Actuator model number
●◇	··· ●: Housing A ◇: Intermediate Flange

■ Housing A

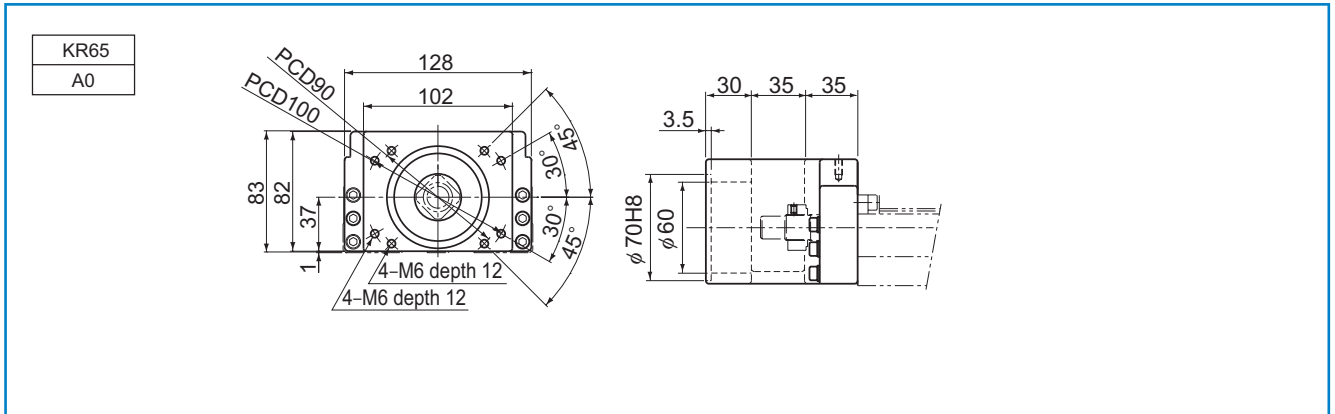

■ Turnaround Housing A

Note) Specify mounting holes when ordering.

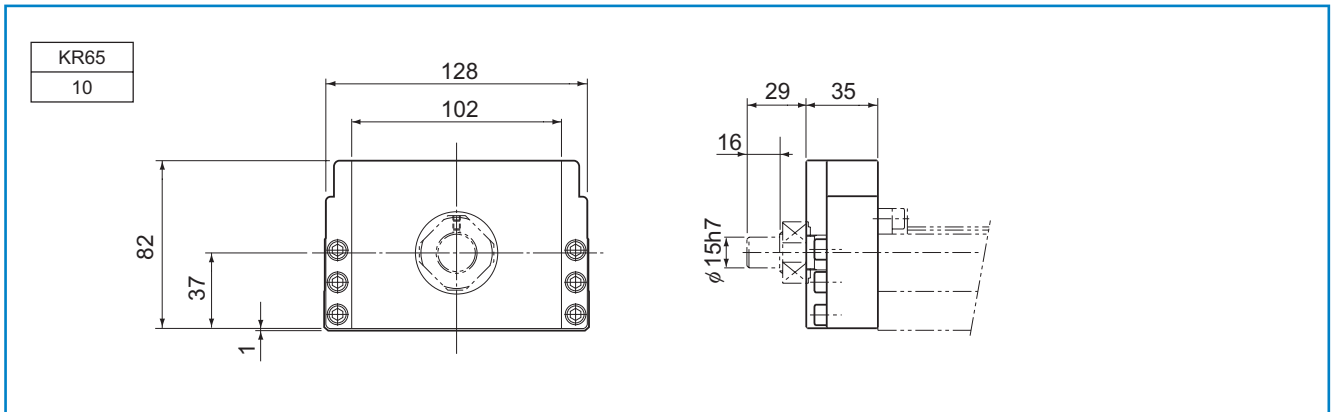

KR65
30

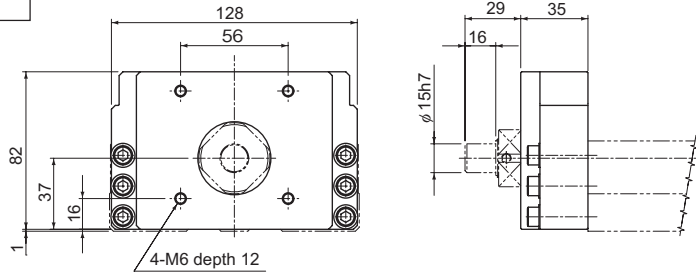

Intermediate Flange

KR65
AV

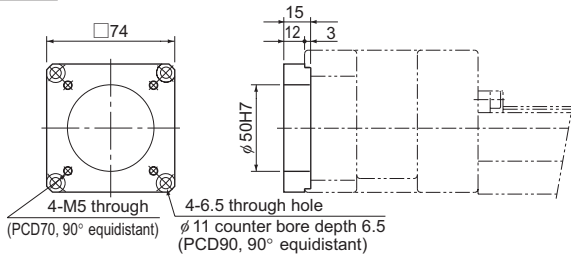

KR65
A5

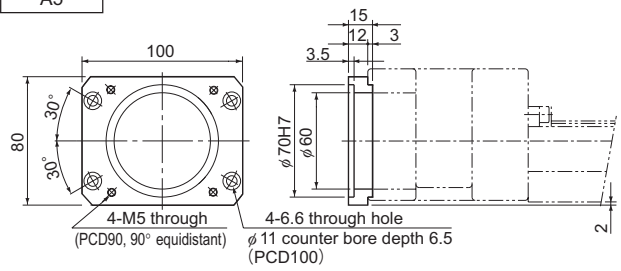

KR65
A6

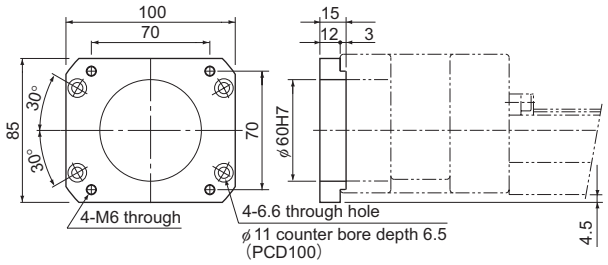

KR65
AZ

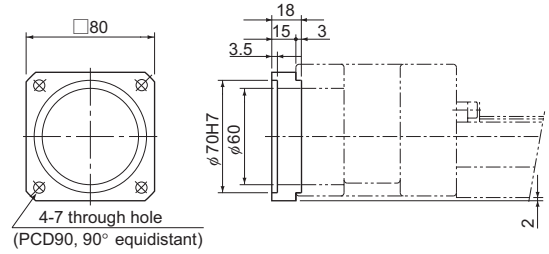

Appendix

Various types of options are available for model KR. Select an appropriate model according to your application. There are also options not contained in this catalog. Contact THK for details.

Name		Overview
Cover	Cover	Serve as contamination protection accessories or the likes
	Bellows	
Sensor	Proximity sensor	Supporting manufacturer: Yamatake, Panasonic Electric Works SUNX
	Photo sensor	Supporting manufacturer: Omron
	Sensor rail	For mounting a sensor
Motor bracket	Housing	For standard type model KR without a motor If the customer manufactures a motor bracket For motor wrap type
	Table of Motors Used in Model KR and Corresponding Intermediate flange	Supporting manufacturer: Yaskawa Electric, Mitsubishi Electric, Panasonic, Sanyo Electric, Omron, Fanuc, Keyence and Oriental Motor
	Intermediate flange dimensional table for model KR	—

Table16 Table of Applicable Options

Model No.	Cover	Bellows	Proximity sensor	Photo sensor	Housing A for a Separate Motor	Turnaround Housing A	Intermediate flange
KR15	○	○	○	—	—	△	○
KR20	○	○	○	○	—	—	○
KR26	○	○	○	○	—	—	○
KR30H	○	○	○	○	—	△	○
KR33	○	○	○	○	○	○	○
KR45H	○	○	○	○	—	△	○
KR46	○	○	○	○	○	○	○
KR55	○	○	○	○	—	○	○
KR65	○	○	○	○	—	○	○

△ : There are also options not contained in this catalog. Contact THK for details.

Cover

For model KR, covers are available as an option.

[Example of Installation]

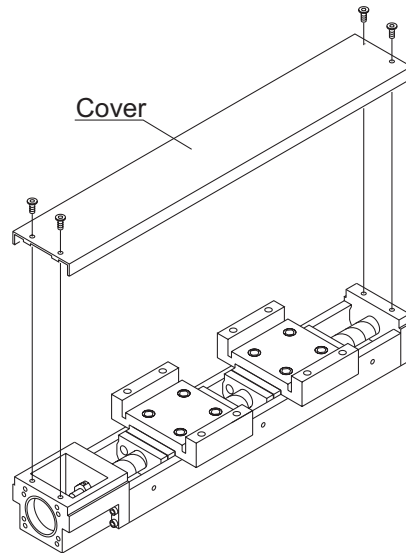

Bellows

● For dimensions of the bellows, see page60 to page64.

For model KR, bellows are available for contamination protection in addition to a cover.

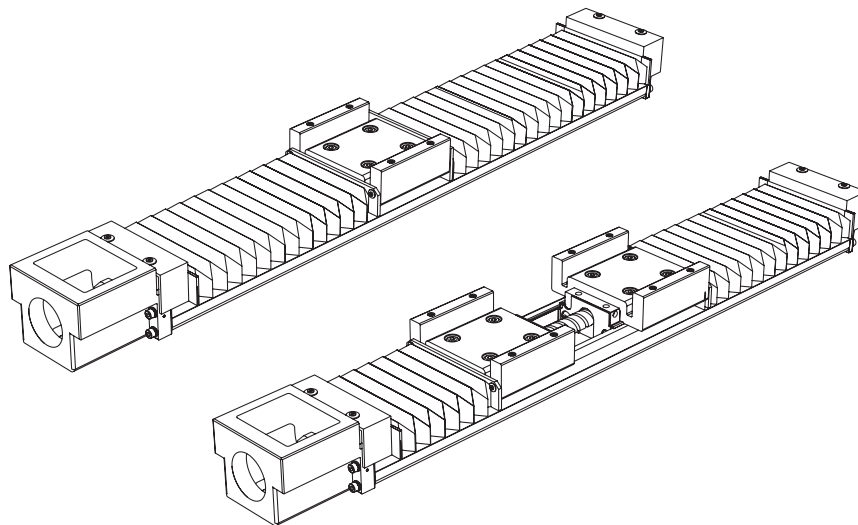

Sensor

● For detailed dimensions, see page65 to page68.

Optional proximity sensors and photo sensors are available for model KR. Models equipped with a sensor are also provided with a dedicated sensor rail/sensor dog.

If the Outer rail length is short, a model having a sensor and a sensor rail attached on both sides is available.

[Installed Example]

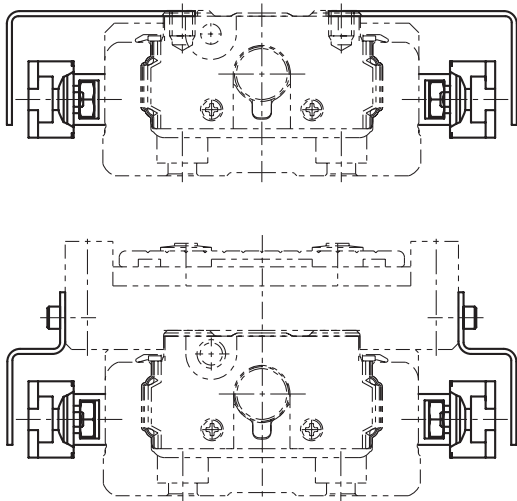

Housing

● For detailed dimensions, see page69 to page83.

[Housing A]

THK also offers Housing A provided with a separate motor, and a turnaround type of Housing A, as options in order to support a motor bracket or a turnaround section that the customer may separately produce.

[Housing A for a Separate Motor]

By using the fitting difference, the user can easily mount a separately manufactured motor bracket.

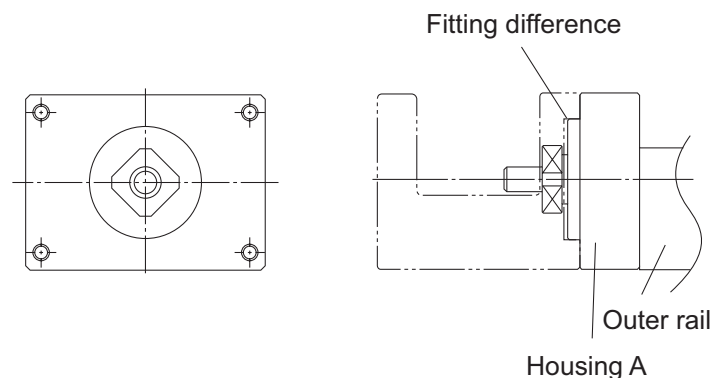

[Turnaround Housing A]

Since the mounting holes are drilled in constant pitch, the user can select the motor bracket orientation.

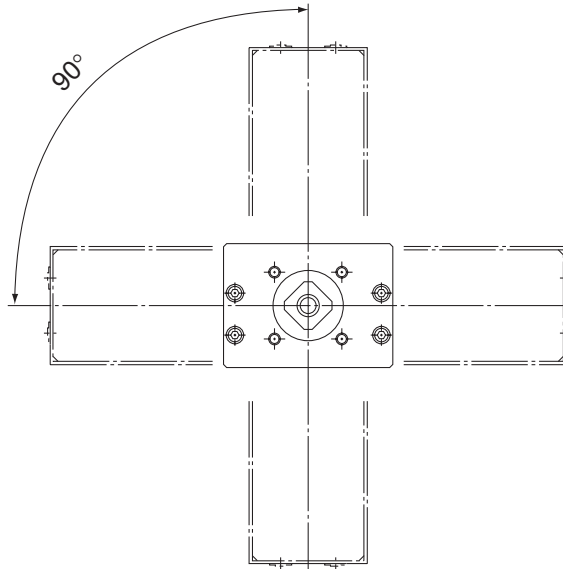

Motor Wrap Type

Model KR are available in “Motor Wrap” types that allow the motor to be turned around in order to minimize the dimension in the longitudinal direction (Pulley ratio:1:1). Contact THK for details.

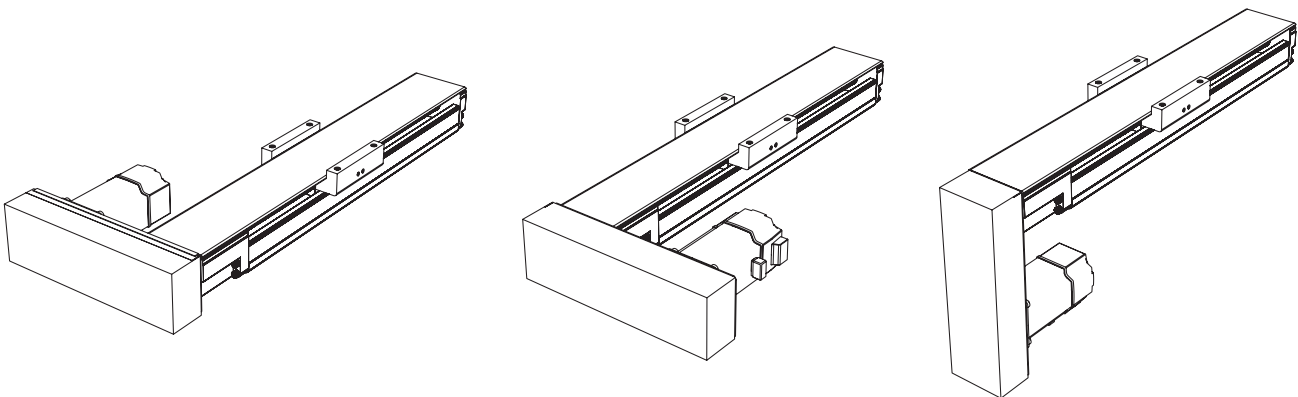

XY Bracket (for Reference)

Brackets for installing models KR33/46 are available. The brackets use aluminum to reduce the weights and keep the inertia as low as possible.

[KR-008XS (for Model KR33, Single-Shaft Type)]

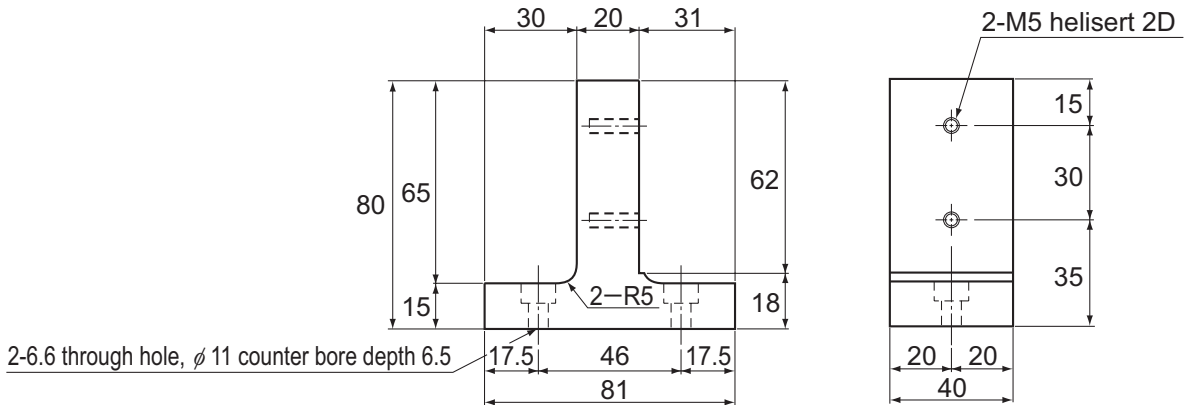

[KR-008XL (for Model KR46, Single-Shaft Type)]

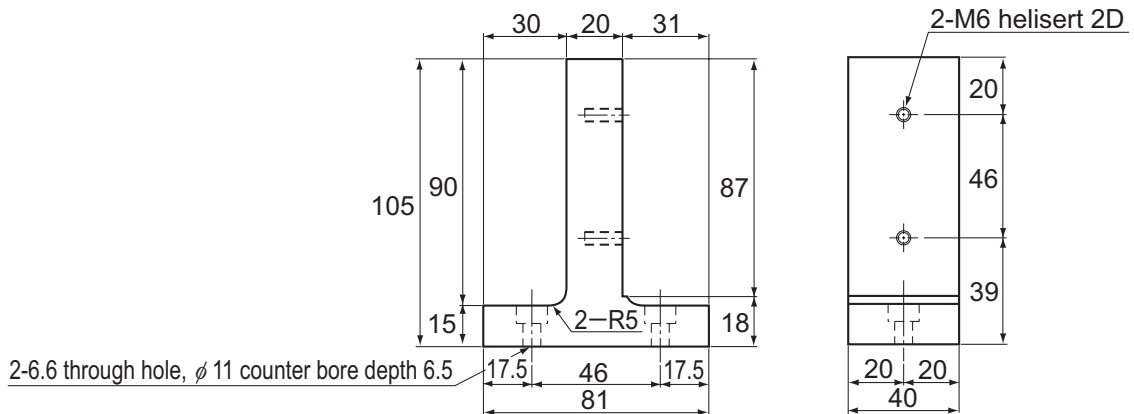

[KR-003XS (for Model KR33, Outer Rail Fixed)]

KR46A+KR33A

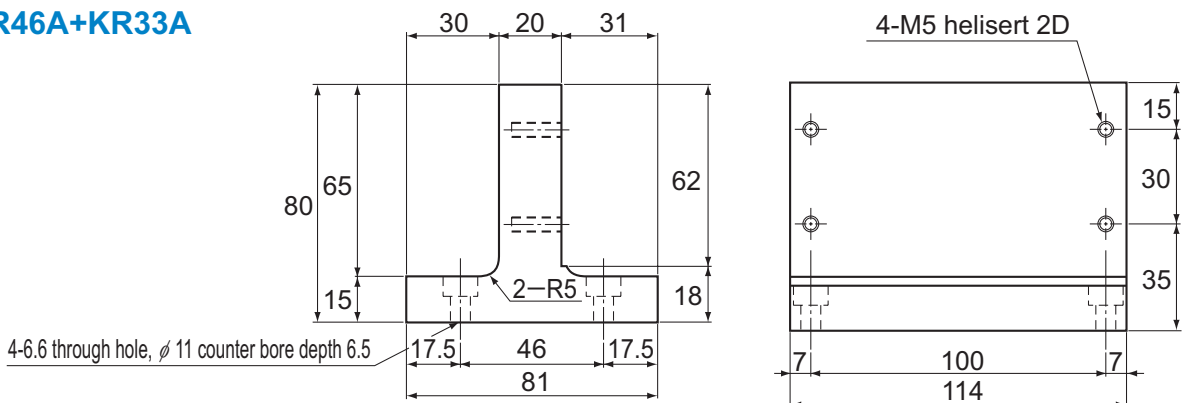

[KR-003XL (for Model KR46, Outer Rail Fixed)]

KR46A+KR46A

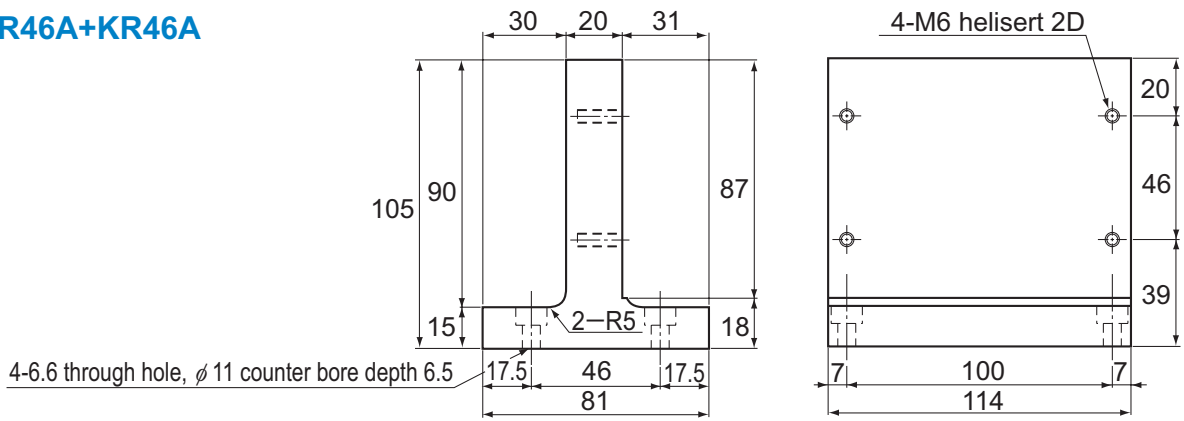

[KR-002XS (for Model KR33, Slider Fixed)]

KR46A+KR33A

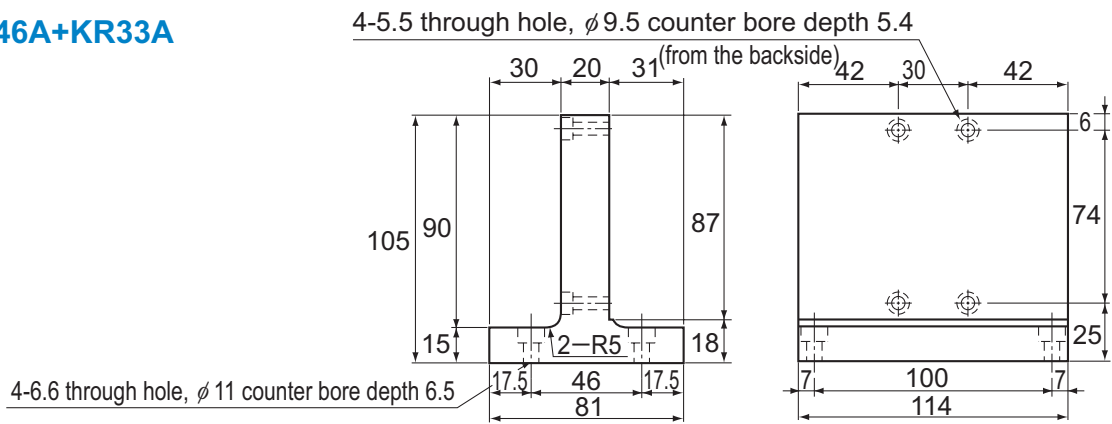

[Example of Combinations]

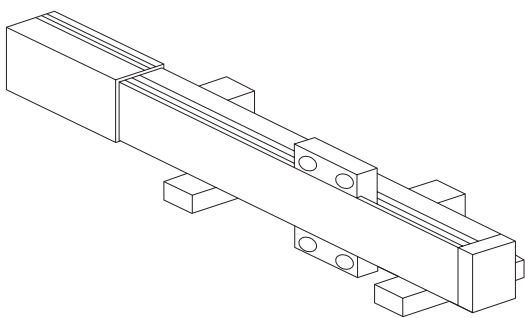

For single shaft

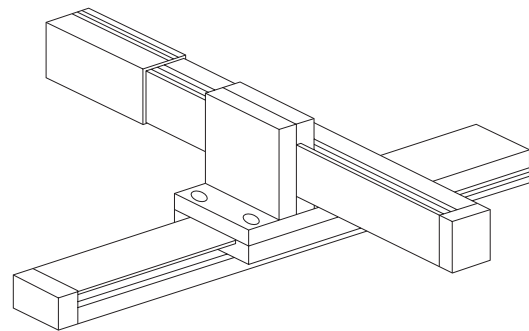

Slider fixed

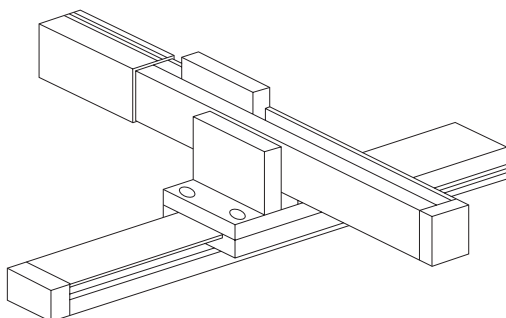

Outer rail fixed

Precautions on Use

[Handling]

- (1) Do not disassemble this product unless absolutely necessary. This will cause dust to enter the product resulting in loss of functionality.
- (2) Take care not to drop or strike this product. This could cause injury or product damage. Giving an impact to it could also cause damage to its function even if the product looks intact.
- (3) Exceeding the dangerous speed may lead the components to be damaged or cause an accident. Be sure to use the product within the specification range designated by THK.
- (4) Foreign material entering the product will cause damage to the ball circulation components and loss of functionality. Prevent foreign material, such as dust or cutting chips, from entering the system.
- (5) When planning to use the product in an environment where the coolant penetrates the inner block, it may cause trouble to product functions depending on the type of the coolant. Contact THK for details.
- (6) The service temperature range of this product is 0 to 40°C (no freezing or condensation). If you consider using this product outside the service temperature range, contact THK.
- (7) If the product will be used in location exposed to vibrations or in special environment such as vacuum/clean-room, and/or high/low temperatures, contact THK.
- (8) If the product is operating or in the ready state, never touch a moving part. In addition, do not enter the operating area of the actuator.
- (9) If two or more people are involved in the operation, confirm the procedures such as a sequence, signs and anomalies in advance, and appoint another person for monitoring the operation.

[Lubrication]

- (1) Thoroughly remove the anti-rust oil before using the product.
- (2) To maximize the performance of model KR, lubrication is required. Using the product without adequate lubrication may induce premature wear in rolling components and/or shorten the service life. Note the standard grease used in the product as follows.
 Model KR15 : THK AFF Grease
 Models KR20 and KR26 : THK AFA Grease
 Models KR30H, KR33, KR45H, KR46, KR55 and KR65 : THK AFB-LF Grease
- (3) Do not mix lubricants of different physical properties.
- (4) Before selecting special lubricant, contact THK.
- (5) When adopting oil lubrication method, contact THK.
- (6) Because the intervals between greasing vary depending on the conditions of product use, it is recommended that the greasing interval be determined through an initial inspection.
- (7) If the product will be used in location exposed to vibrations or in special environment such as vacuum/clean-room, and/or high/low temperatures, contact THK.

[Storage]

Model KR should be stored in a horizontal orientation in the THK wrapping and package, avoiding high or low temperatures and high levels of humidity.

[Instruction Manual]

You can download the “LM Guide Actuator Model KR -- Instruction Manual” from the THK technical support website. Technical support website: <https://tech.thk.com/>

THK LM Guide Actuator Model KR

THK CO., LTD.

HEAD OFFICE 3-11-6, NISHI-GOTANDA, SHINAGAWA-KU, TOKYO 141-8503 JAPAN
INTERNATIONAL SALES DEPARTMENT PHONE:+81-3-5434-0351 FAX:+81-3-5434-0355
Global site : <http://www.thk.com/>

NORTH AMERICA

THK America, Inc.

● HEADQUARTERS

Phone:+1-847-310-1111 Fax:+1-847-310-1271

● CHICAGO OFFICE

Phone:+1-847-310-1111 Fax:+1-847-310-1182

● NORTH EAST OFFICE

Phone:+1-631-244-1565 Fax:+1-631-244-1565

● ATLANTA OFFICE

Phone:+1-770-840-7990 Fax:+1-770-840-7897

● LOS ANGELES OFFICE

Phone:+1-949-955-3145 Fax:+1-949-955-3149

● SAN FRANCISCO OFFICE

Phone:+1-925-455-8948 Fax:+1-925-455-8965

● DETROIT OFFICE

Phone:+1-248-858-9330 Fax:+1-248-858-9455

● TORONTO OFFICE

Phone:+1-905-820-7800 Fax:+1-905-820-7811

SOUTH AMERICA

THK BRAZIL INDUSTRIA E COMERCIO LTDA.

Phone:+55-11-3767-0100 Fax:+55-11-3767-0101

EUROPE

THK GmbH

● EUROPEAN HEADQUARTERS

Phone:+49-2102-7425-555 Fax:+49-2102-7425-556

● DÜSSELDORF OFFICE

Phone:+49-2102-7425-0 Fax:+49-2102-7425-299

● STUTTGART OFFICE

Phone:+49-7141-4988-500 Fax:+49-7141-4988-888

● U.K. OFFICE

Phone:+44-1384-47-1550 Fax:+44-1384-47-1551

● ITALY OFFICE

Phone:+39-02-9901-1801 Fax:+39-02-9901-1881

● SWEDEN OFFICE

Phone:+46-8-445-7630 Fax:+46-8-445-7639

● AUSTRIA OFFICE

Phone:+43-7229-51400 Fax:+43-7229-51400-79

● SPAIN OFFICE

Phone:+34-93-652-5740 Fax:+34-93-652-5746

● TURKEY OFFICE

Phone:+90-216-362-4050 Fax:+90-216-569-7150

● PRAGUE OFFICE

Phone:+420-2-41025-100 Fax:+420-2-41025-199

● MOSCOW OFFICE

Phone:+7-495-649-80-47 Fax:+7-495-649-80-44

THK Europe B.V.

● EINDHOVEN OFFICE

Phone:+31-040-290-9500 Fax:+31-040-290-9599

THK France S.A.S.

Phone:+33-4-3749-1400 Fax:+33-4-3749-1401

CHINA

THK (CHINA) CO.,LTD.

● HEADQUARTERS

Phone:+86-411-8733-7111 Fax:+86-411-8733-7000

● SHANGHAI OFFICE

Phone:+86-21-6219-3000 Fax:+86-21-6219-9890

● BEIJING OFFICE

Phone:+86-10-8441-7277 Fax:+86-10-6590-3557

● CHENGDU OFFICE

Phone:+86-28-8526-8025 Fax:+86-28-8525-6357

● GUANGZHOU OFFICE

Phone:+86-20-8523-8418 Fax:+86-20-3801-0456

● SHENZHEN OFFICE

Phone:+86-755-2642-9587 Fax:+86-755-2642-9604

● XIAN OFFICE

Phone:+86-29-8834-1712 Fax:+86-29-8834-1710

THK (SHANGHAI) CO.,LTD.

Phone:+86-21-6275-5280 Fax:+86-21-6219-9890

TAIWAN

THK TAIWAN CO.,LTD.

● TAIPEI HEAD OFFICE

Phone:+886-2-2888-3818 Fax:+886-2-2888-3819

● TAICHUNG OFFICE

Phone:+886-4-2359-1505 Fax:+886-4-2359-1506

● TAINAN OFFICE

Phone:+886-6-289-7668 Fax:+886-6-289-7669

KOREA

SEOUL REPRESENTATIVE OFFICE

Phone:+82-2-3468-4351 Fax:+82-2-3468-4353

SINGAPORE

THK LM SYSTEM Pte.Ltd.

Phone:+65-6884-5500 Fax:+65-6884-5550

THAILAND

THK LM System Pte.Ltd.Representative Office in Thailand

Phone:+660-2751-3001 Fax:+660-2751-3003

INDIA

THK India Pvt. Ltd.

Phone:+91-80-2340-9934 Fax:+91-80-2340-9937