

**Sumitomo Drive Technologies**  
*Always on the Move*

# Motion Control Drives

FINE CYCLO®  
F2C-C series



## Table of Contents

1. Construction.....	1
2. Application Examples.....	3
3. Nomenclature.....	4
4. Products.....	4
5. Speed Ratio & Rotation Direction.....	4
6. Operating Principles.....	5
7. Rating.....	6
8. Engineering Data.....	8
9. Main Bearings.....	11
10. Selection.....	12
11. Nortice for Designing.....	14
12. Outline Drawing.....	16

Motion Control Drives  
FINE CYCLO®

# F2C-C series

**NEW**

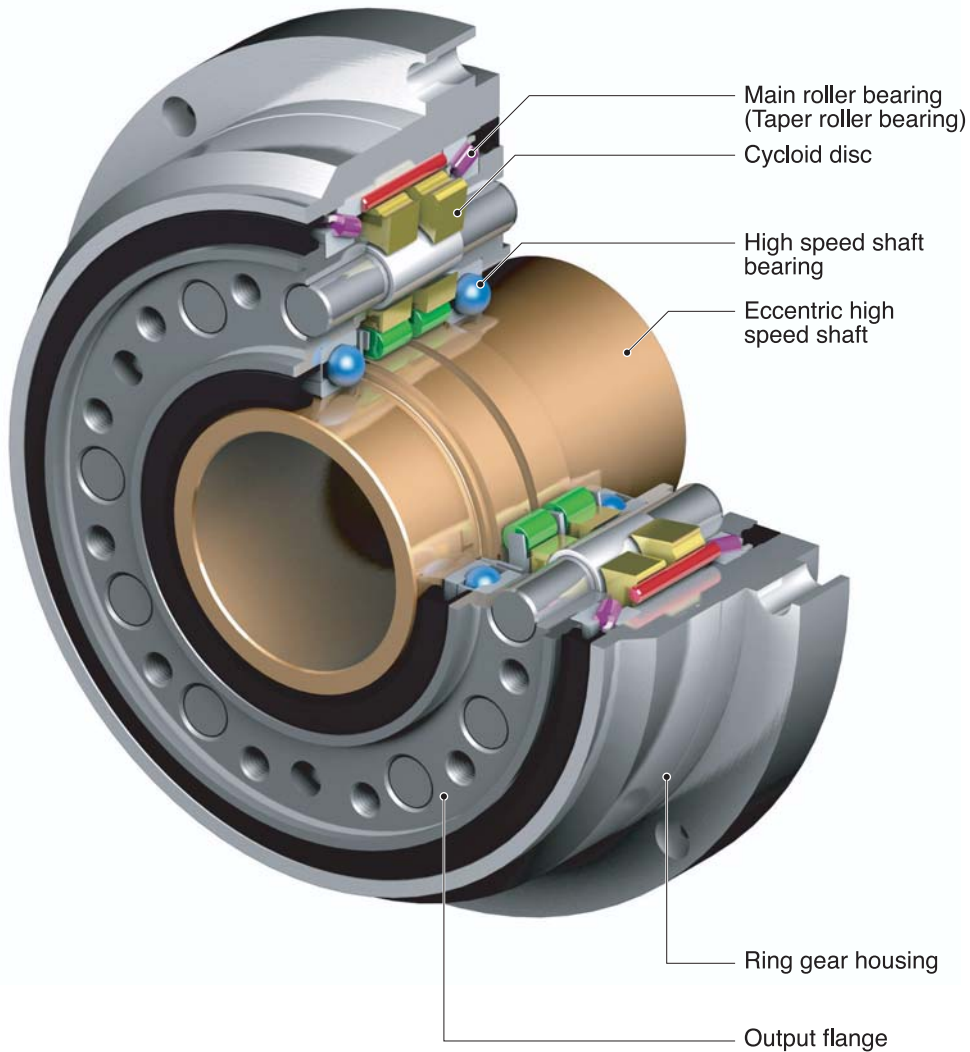

### Large Hollow Bore

Enlarged hollow diameter enables effective use of space for cable or shaft.

### Reduces Man-Hour for Assembly

High-speed shaft supported by the reducer simplifies coupling with motor.

### Complete Sealed Design

Grease is sealed inside the reducer. Customers are released from the sealing work.

### Compact Design

Simple construction with less number of parts than single stage reducer mechanism.

# 1. Construction

Fig. C-1

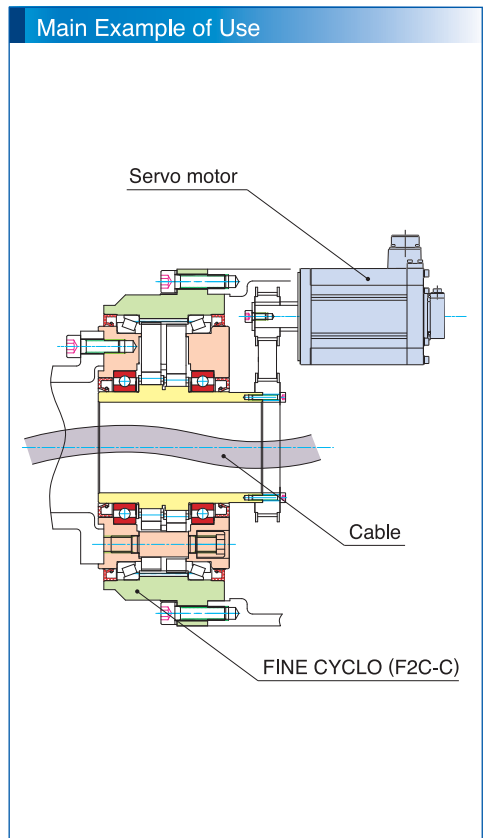
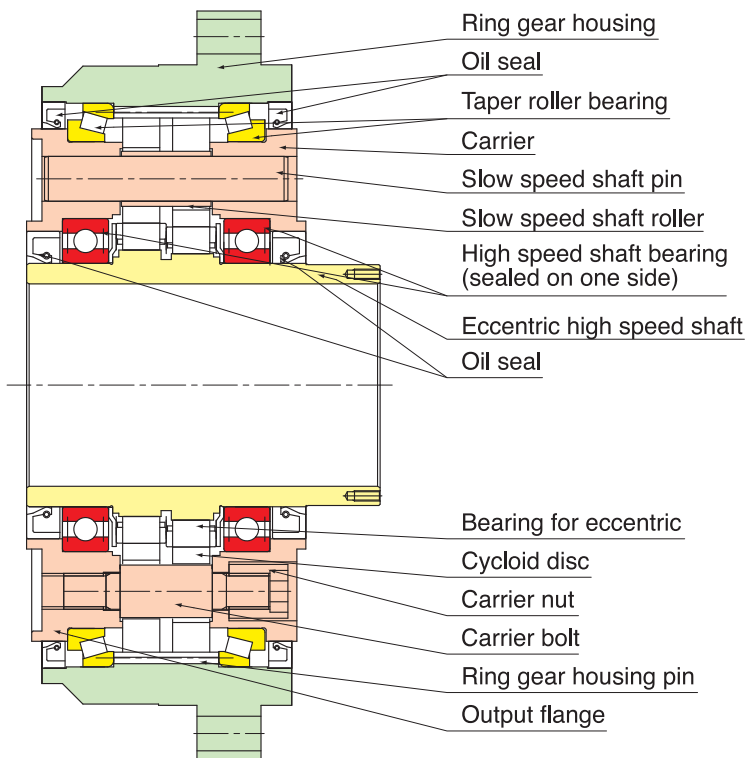

# 2. Application Examples

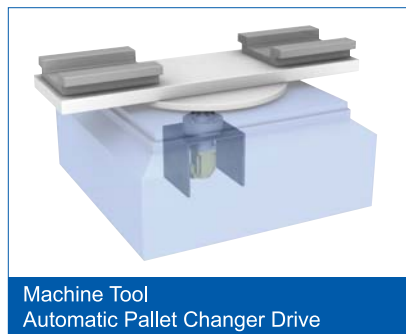

### 3. Nomenclature

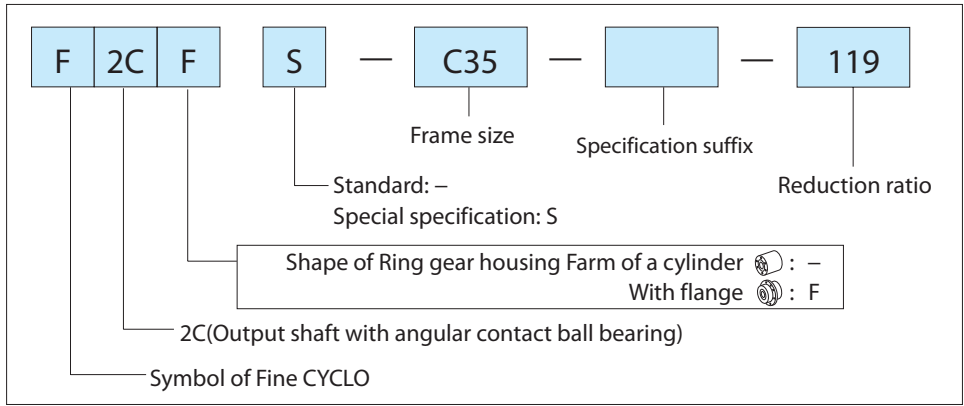

### 4. Products

Mark • : Model Lineup

Frame size	Reduction ratio		
	59	89	119
C25	•	•	•
C35	•	•	•
C45	•	•	•
C55	•	•	•
C65	•	•	•

### 5. Speed Ratio & Rotation Direction

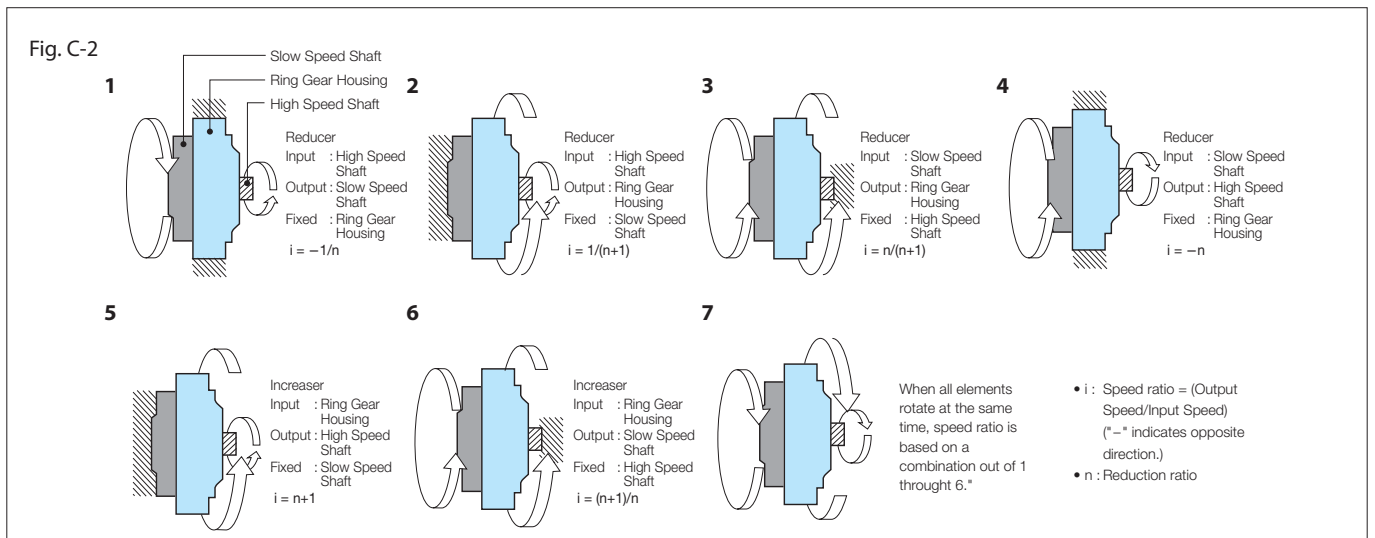

# 6. Operating Principles

The reducer portion of the FINE CYCLO® is fundamentally different in principle and mechanism from the involute gearing mechanism of competitive gearmotors. The unique speed reducer portion is an ingenious combination of the following two mechanisms:

- ☆ A combination of a planet gear and a fixed internal sun gear. In the FINE CYCLO®, the planet gear has cycloidal-shaped teeth and the sun gear has circular pin teeth. The number of teeth in the planet gear is one or two less than the sun gear.
- ☆ A constant speed internal gearing mechanism.

Fig. C-3 Principle of internal Planetary Gearing

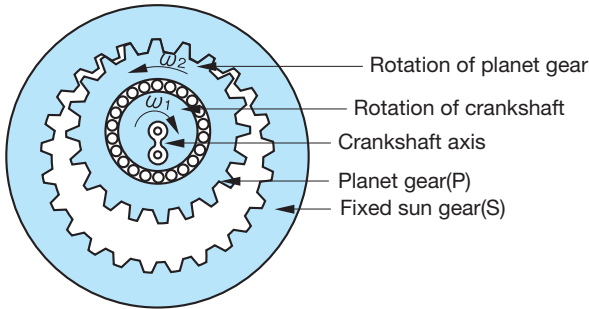

See Fig. C-3

In equation 1, below, P identifies the number of the planet gear teeth, S that of the sun gear, w<sub>2</sub> the angular velocity of the planet gear around its own axis. The velocity ratio of w<sub>2</sub> to w<sub>1</sub> is shown as follows:

$$\frac{\omega_2}{\omega_1} = 1 - \frac{S}{P} = - \frac{S-P}{P} \dots \text{Equation 1}$$

With S greater by one or two than P in this equation, the highest velocity ratio is obtainable.

That is, if S-P=1 is applied to Equation 1, the velocity ratio may be calculated from the following equation:

$$\frac{\omega_2}{\omega_1} = \frac{1}{P} \dots \text{Equation 2}$$

Or if S-P=2 is applied to Equation 1, the velocity ratio may be calculated from the following equation:

$$\frac{\omega_2}{\omega_1} = \frac{2}{P} \dots \text{Equation 3}$$

As the crankshaft rotates at the angular velocity w<sub>1</sub> around the axis of the sun gear, the planet gear rotates at the angular velocity:

$$- \frac{1\omega_1}{P} \text{ or } - \frac{2\omega_1}{P}$$

Fig. C-4 Epitrochoid Planet Gear-Circular(PIN) Tooth Sun Gear Combination

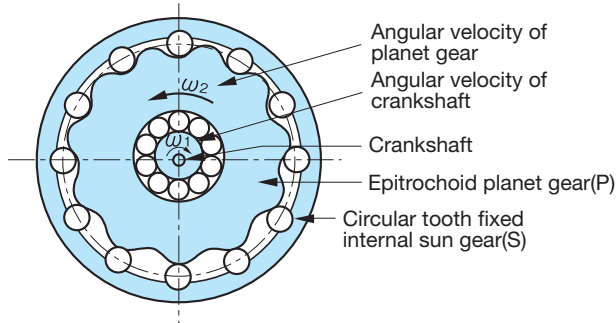

Fig. C-5 Constant Speed Internal Gearing

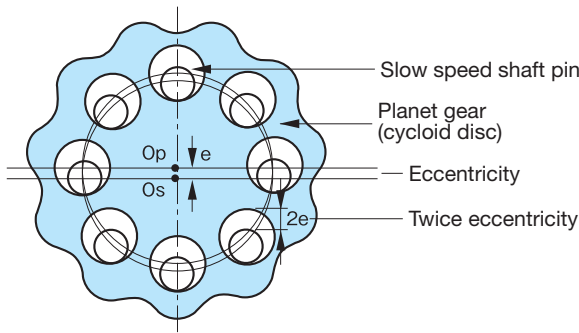
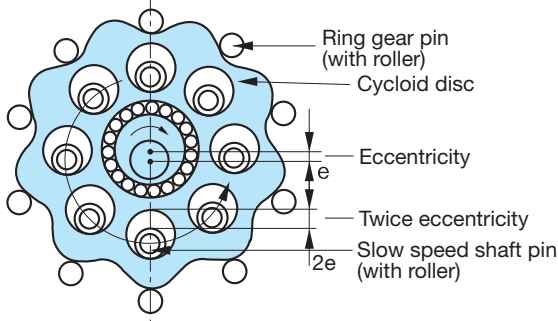

Fig. C-6 Combination of Planet-Sun Gears and Constant Speed Internal Gear



When P indicates the number of the teeth of the planet gear and the symbol indicates that the rotation of the planet gear is in a reverse direction to that of the crankshaft.

In the FINE CYCLO®, illustrated in Fig. C-4, circular teeth(pins) are adapted for the sun gear and epitrochoid curved teeth for the planet gear, thereby avoiding tooth top interference. The rotation of the planet gear around its own axis is taken out through a constant speed internal gearing mechanism as shown in Fig. C-5.

In this mechanism shown in Fig. C-6, the pins of the slow speed shaft are evenly spaced on a circle that is concentric to the axis of the sun gear. The pins transmit the rotation of the planet gear by rolling internally on the circumference of the bores of each planet gear or cycloid disc. The diameter of the bores minus the diameter of the slow speed shaft pins is equal to twice the eccentricity value of the crank shaft (eccentric). This mechanism smoothly transmits only the rotation of the planet gear around its own axis to the slow speed shaft.

# 7. Rating

Table C-1 Rating Table (Input rotation base)

Input speed $n_1$ (r/min)			2500			2000			1750			1500		
Model	Frame size	Reduction ratio	Rated output torque (Upper/N·m) (Lower/kgf·m)	Output speed (r/min)	Allowable input power (kW)	Rated output torque (Upper/N·m) (Lower/kgf·m)	Output speed (r/min)	Allowable input power (kW)	Rated output torque (Upper/N·m) (Lower/kgf·m)	Output speed (r/min)	Allowable input power (kW)	Rated output torque (Upper/N·m) (Lower/kgf·m)	Output speed (r/min)	Allowable input power (kW)
F2C	C25	59	370 37.7	42.4	2.19	396 40.4	33.9	1.87	412 42	29.7	1.70	432 44.0	25.4	1.53
		89	370 37.7	28.1	1.45	396 40.4	22.5	1.24	412 42	19.7	1.13	432 44.0	16.9	1.01
		119	370 37.7	21.0	1.08	396 40.4	16.8	0.93	412 42	14.7	0.84	432 44.0	12.6	0.76
F2CF	C35	59				754 76.9	33.9	3.56	785 80	29.7	3.24	822 83.8	25.4	2.91
		89				754 76.9	22.5	2.36	785 80	19.7	2.15	822 83.8	16.9	1.93
		119				754 76.9	16.8	1.77	785 80	14.7	1.61	822 83.8	12.6	1.44
F2CF	C45	59							1275 130	29.7	5.27	1336 136	25.4	4.73
		89							1275 130	19.7	3.50	1336 136	16.9	3.14
		119							1275 130	14.7	2.61	1336 136	12.6	2.35
F2CF	C55	59										2055 209	25.4	7.28
		89										2055 209	16.9	4.83
		119										2055 209	12.6	3.61
F2CF	C65	59												
		89												
		119												

Table C-2 Maximum acceleration or deceleration torque

Frame size	Maximum acceleration or deceleration torque		Peak torque for emergency stop	
	(N·m)	(kgf·m)	(N·m)	(kgf·m)
C25	1030	105	2060	210
C35	1962	200	3924	400
C45	3188	325	6377	650
C55	4316	440	8633	880
C65	6278	640	12577	1280

1000			750			600			Allowable maximum input speed (r/min)	Allowable maximum input speed(r/min)		Equivalent On input shaft Upper/Moment of inertia (x10 <sup>-4</sup> kg·m <sup>2</sup> ) Lower/GD <sup>2</sup> (x10 <sup>-4</sup> kgf·m <sup>2</sup> )	Mass (kg)
Rated output torque (Upper/N·m) (Lower/kgf·m)	Output speed (r/min)	Allowable input power (kW)	Rated output torque (Upper/N·m) (Lower/kgf·m)	Output speed (r/min)	Allowable input power (kW)	Rated output torque (Upper/N·m) (Lower/kgf·m)	Output speed (r/min)	Allowable input power (kW)		50% ED	100% ED		
487 49.7	16.9	1.15	531 54.2	12.7	0.94	568 57.9	10.2	0.81	3500	2900	1450	6.95 27.8	12.5
487 49.7	11.2	0.76	531 54.2	8.4	0.62	568 57.9	6.7	0.53	3500	2900	1450	6.90 27.6	
487 49.7	8.4	0.57	531 54.2	6.3	0.47	568 57.9	5.0	0.40	3500	2900	1450	6.90 27.6	
928 94.6	16.9	2.19	1012 103	12.7	1.79	1082 110	10.2	1.53	2500	2100	1050	28.5 114	21
928 94.6	11.2	1.45	1012 103	8.4	1.19	1082 110	6.7	1.02	2500	2100	1050	28.5 114	
928 94.6	8.4	1.09	1012 103	6.3	0.89	1082 110	5.0	0.76	2500	2100	1050	28.5 114	
1508 154	16.9	3.56	1644 168	12.7	2.91	1758 179	10.2	2.49	2100	1800	900	61.3 245	32
1508 154	11.2	2.36	1644 168	8.4	1.93	1758 179	6.7	1.65	2100	1800	900	61.0 244	
1508 154	8.4	1.77	1644 168	6.3	1.44	1758 179	5.0	1.24	2100	1800	900	61.0 244	
2321 237	16.9	5.48	2530 258	12.7	4.48	2705 276	10.2	3.83	1800	1500	750	114 456	45
2321 237	11.2	3.63	2530 258	8.4	2.97	2705 276	6.7	2.54	1800	1500	750	114 454	
2321 237	8.4	2.72	2530 258	6.3	2.22	2705 276	5.0	1.90	1800	1500	750	114 454	
3713 378	16.9	8.77	4048 413	12.7	7.17	4328 441	10.2	6.14	1700	1400	700	200 799	62
3713 378	11.2	5.82	4048 413	8.4	4.75	4328 441	6.7	4.07	1700	1400	700	199 796	
3713 378	8.4	4.35	4048 413	6.3	3.56	4328 441	5.0	3.04	1700	1400	700	199 796	

□ : 50%ED range □ : 100%ED range

Notes:

- Rated output torque  
Rated output torque implies allowable mean load torque at each output speed. Rated output torque for below 600r/min input is the same as 600r/min.  
Allowable input power is the value converted from rated output torque, when it is 100%. This value takes efficiency of FINE CYCLO® in consideration.
- Allowable maximum input speed and allowable mean input speed  
Reducer may be used within maximum input speed indicated in the Table, however, allowable mean input speed is limited by operation (%ED).
- Allowable acceleration or deceleration peak torque  
Allowable peak torque at normal start and stop.
- Allowable momentary maximum torque  
Allowable momentary maximum torque at emergency stop or heavy shock, when loading 1000 times in overall lifetime.
- Moment of inertia, GD<sup>2</sup>  
Value at input shaft. Divide them by g (Moment of inertia: 9.8m/sec<sup>2</sup>) or 4g (GD<sup>2</sup>: 4 x 9.8m/sec<sup>2</sup>) to convert from them to inertia.
- Calculate the rated torque using the following formula when the speed is not shown in the table above.

$$T_{2N} = T_{2N,600} \left( \frac{600}{n_1} \right)^{0.3}$$

$T_{2N}$ : Rated torque at input speed  $n_1$   
 $T_{2N,600}$ : Rated torque at input speed  $n_1$  is 600r/min



# 8. Engineering Data

## 8-1. Stiffness and lost motion

- Hysteresis curve Relationship between load and displacement of output flange (rotational angle) when load is removed slowly from allowable torque to zero torque, with fixed input shaft.
- Lost Motion Torsional deflected angle at ±3% allowable output torque.
- Stiffness Slope of the straight line connecting two points, when allowable torque is 50% and 100% on the hysteresis curve.

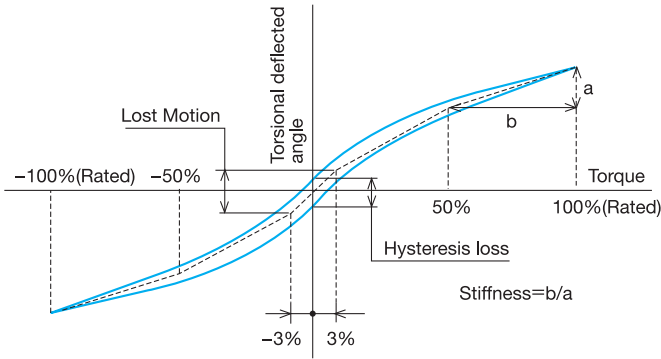

Fig. C-7 Hysteresis curve

## 8-2. No Load Running Torque

No load running torque indicates torque on input shaft for rotating reducer under no-load condition.

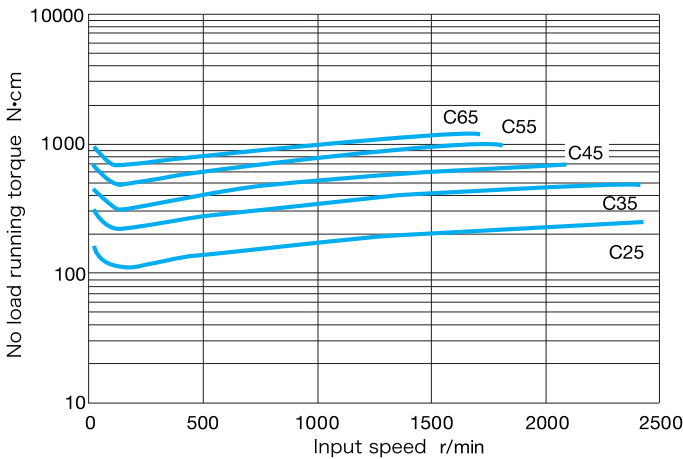

Fig. C-8

- Notes) 1. Fig. C-8 shows average data after reducers have been run.  
2. Measurement Conditions

Ring gear housing temperature	Approx. 30°C
Accuracy in assembled dimensions	Refer to 11.1
Lubrication	Standard grease

Table C-3 Engineering data

Frame size	Rated output torque at input speed 1750 r/min	Lost Motion		Stiffness
		Measured torque	Lost Motion	
	Nm	Nm	arc min	Nm/arc min
C25	412	12.4	1.0	128
C35	785	23.5		294
C45	1275	38.3		491
C55	1962	58.9		687
C65	3139	94.2		1030

Note) arc min means "minute" of the angle. Stiffness is the average value (typical data).

### (Example calculation of torsional deflected angle)

Calculation of torsion angle when torque is applied in one direction using C35 as example.

1) When load torque is 15N·m

(When load torque is in the range of lost motion)

$$\theta = \frac{15}{23.5} \times \frac{1}{2} = 0.32 \text{ arcmin}$$

2) When load torque is 600N·m

$$\theta = \frac{1}{2} \times \frac{600-23.5}{294} = 2.5 \text{ arcmin}$$

### 8-3. No-Load Friction Torque on Output Shaft

Indicates torque necessary to start rotation from output side of reducer from stop without load.

Table C-4 Value of no-load friction torque on output shaft

Frame size	No-load friction torque on output shaft	
	N·m	kgfm
C25	59	6
C35	118	12
C45	147	15
C55	245	25
C65	343	35

Notes: 1. Table C-4 shows average data after reducers have been run.  
2. Measurement Conditions

Accuracy in assembled dimensions	Refer Item 11-1
Lubrication	Standard grease

### 8-4. Efficiency

Fig. C-9 Efficiency Curve (Frame size C25-C45)

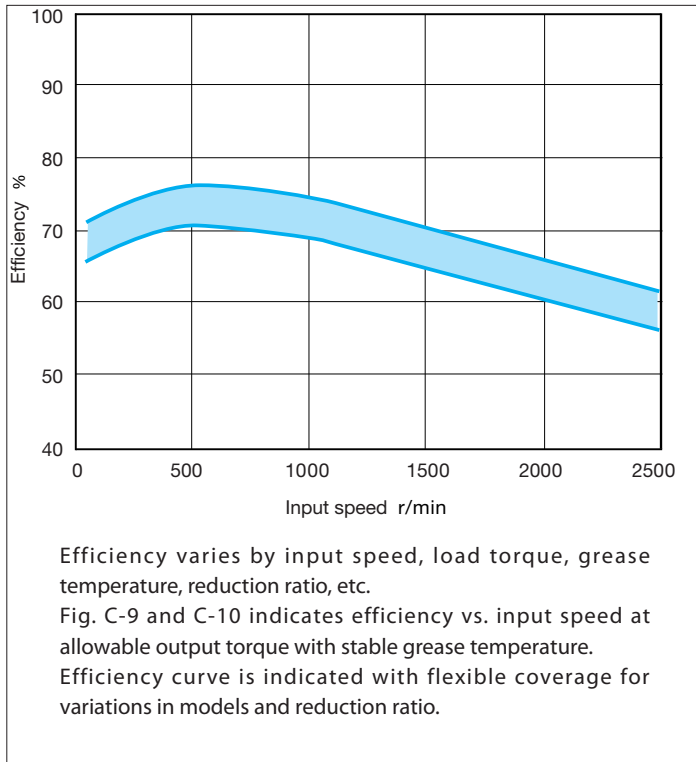

Fig. C-10 (Frame size C55-C65)

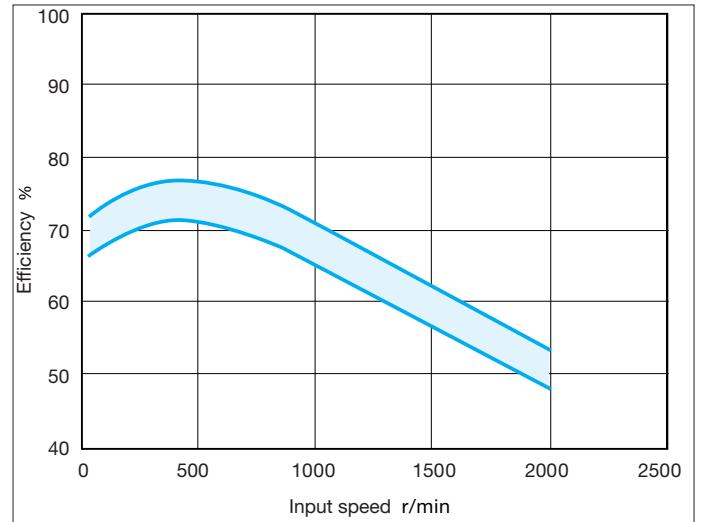
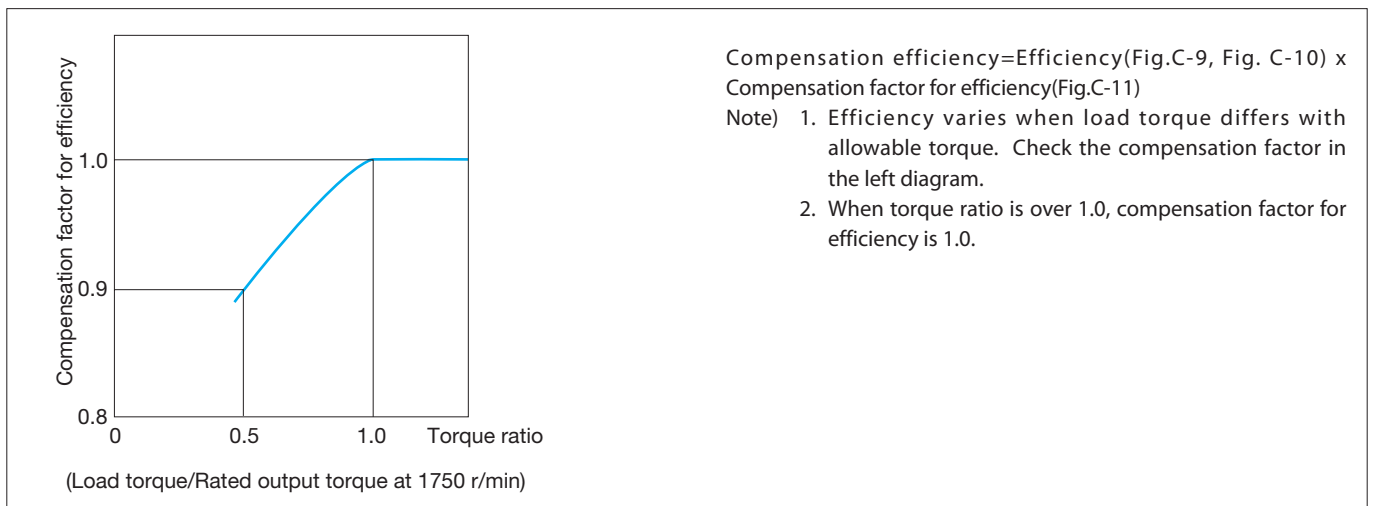

Fig. C-11 Compensation Curve of Efficiency



### 8-5. ALLOWABLE RADIAL LOAD & AXIAL LOAD OF HIGH SPEED SHAFT

When a gear or sheave is mounted on the high speed shaft, radial load and axial load should be equal to or less than allowable value. Check radial & axial load by following the next formula (1)-(3).

(1) Radial load  $P_r$

$$P_r = \frac{T \ell}{R} \leq \frac{P_{ro}}{L_f C_f F_{S1}} \quad [\text{N, kgf}] \quad (\text{Formula C-1})$$

(2) Axial load  $P_a$

$$P_a \leq \frac{P_{ao}}{C_f F_{S1}} \quad [\text{N, kgf}] \quad (\text{Formula C-2})$$

(3) When radial and axial load co-exist

$$\left( \frac{P_r L_f}{P_{ro}} + \frac{P_a}{P_{ao}} \right) \cdot C_f F_{S1} \leq 1 \quad (\text{Formula C-3})$$

$P_r$  : Actual radial load [N, kgf]

$T \ell$  : Equivalent torque on input shaft [N·m, kgf·m]

$R$  : Pitch circle radius of sprocket, gear, or sheave [m]

$P_{ro}$  : Allowable radial load [N, kgf] (Table C-5)

$P_a$  : Actual axial load [N, kgf]

$P_{ao}$  : Allowable axial load [N, kgf] (Table C-6)

$L_f$  : Load location factor (Table C-7)

$C_f$  : Coupling factor (Table C-8)

$F_{S1}$  : Shock factor (Table C-9)

Table C-5 Actual radial load  $P_{ro}$ (Up: N/Down: kgf)

Frame size	Input speed r/min						
	2500	2000	1750	1500	1000	750	600
C25		563	589	620	709	781	841
		57	60	63	72	80	86
C35			687	723	828	911	981
			70	74	84	93	100
C45			785	826	946	1041	1121
			80	84	96	106	114
C55				981	1123	1236	1332
				100	114	126	136
C65					1419	1561	1682
					145	159	171

Table C-6 Actual axial load  $P_{ao}$ (Up: N/Down: kgf)

Frame size	Input speed r/min						
	2500	2000	1750	1500	1000	750	600
C25	540	589	628	677	824	942	1040
	55	60	64	69	84	96	106
C35		746	795	863	1040	1197	1334
		76	81	88	106	122	136
C45			912	981	1197	1373	1530
			93	100	122	140	156
C55				1481	1785	2050	2276
				151	182	209	232
C65					2570	2953	3286
					262	301	335

Table C-7 Load Location Factor  $L_f$

L (mm)	Frame size				
	C25	C35	C45	C55	C65
5	0.80	0.76	0.75	0.73	0.73
10	0.86	0.81	0.79	0.77	0.77
15	0.92	0.86	0.83	0.80	0.80
20	0.98	0.90	0.87	0.84	0.84
25	1.14	0.95	0.91	0.88	0.87
30	1.36	1.00	0.95	0.91	0.90
35	1.59	1.17	0.99	0.95	0.94
40	1.82	1.33	1.11	0.99	0.97
45		1.50	1.25	1.07	1.02
50		1.67	1.39	1.19	1.14
60		2.00	1.67	1.43	1.36
70			1.94	1.67	1.59
80				1.90	1.82
$L_f$ =When 1 of L(mm)	22	30	36	42	44

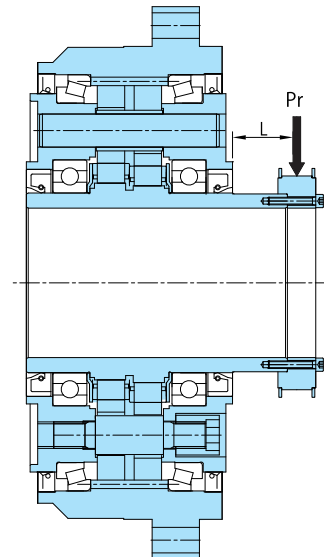

Fig. C-12 Load location on input shaft

Table C-8 Coupling Factor  $C_f$

Coupling method	$C_f$
Chain	1
Machine gear or pinion	1.25
Timing belt	1.25
V-Belt	1.5

Table C-9 Shock Factor  $F_{S1}$

Degree of shock	$F_{S1}$
Practically no shock	1
Light shock	1-1.2
Severe shock	1.4-1.6

# 9. Main Bearings

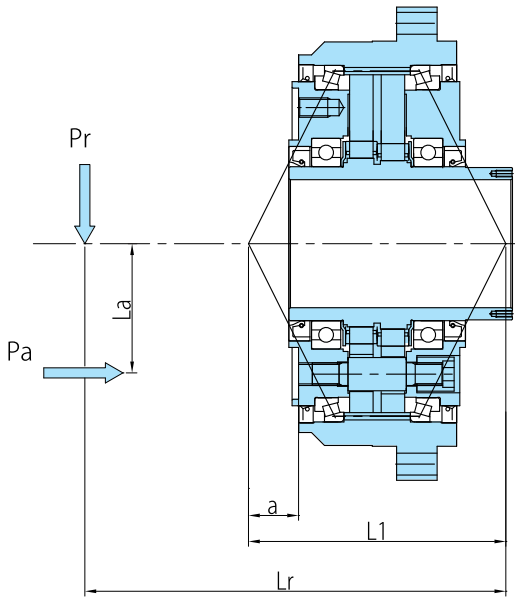

Fig. C-13 Span between each loading point  
 Note) Consult us if:  $L_r > 4 \times L_1$

Pr: Actual radial load(N, kgf)  
 Pa: Actual axial load(N, kgf)

Table C-10 Span of Loading Points(mm)

Frame size	Span of Loading Points	
	L1(mm)	a(mm)
C25	102	13.5
C35	135.2	24.6
C45	158.8	30.9
C55	191.8	41.9
C65	211.8	46.4

Table C-11 Moment Stiffness

Frame size	Moment Stiffness (N-m/arcmin)
C25	883
C35	1668
C45	2649
C55	3924
C65	5690

Table C-12 Allowable Moment & Allowable Axial Load

Frame size	Allowable Moment (N-m)	Allowable Axial Load (N)
C25	1619	5396
C35	2551	6867
C45	3924	8339
C55	6082	10791
C65	8829	13734

1. Moment Stiffness  
 Indicates stiffness on inclination of output shaft with external moment.

External moment (M)  
 $M = PrL_r + PaL_a$  ..... (Formula C-4)

2. Allowable Moment & Allowable Axial Load  
 Check external moment and external axial load with Formula C-5, Formula C-6, and Fig.C-13.

Equivalent moment (Me)  
 $Me = C_f F_{S1} PrL_r + C_f F_{S1} PaL_a$  ..... (Formula C-5)

Equivalent axial load (Pae)  
 $Pae = C_f F_{S1} Pa$  ..... (Formula C-6)

Cf : Coupling factor [Table C-13]  
 F<sub>S1</sub>: Shock factor [Table C-14]

Table C-13 Coupling Factor Cf

Load connection factor	Cf
General purpose chain	1
Machine gear or pinion	1.25
Timing belt	1.25
V-Belt	1.5

Table C-14 Shock factor F<sub>S1</sub>

Load Classification	F <sub>S1</sub>
Uniform load (no shock)	1
Moderate shocks	1-1.2
Heavy shocks	1.4-1.6

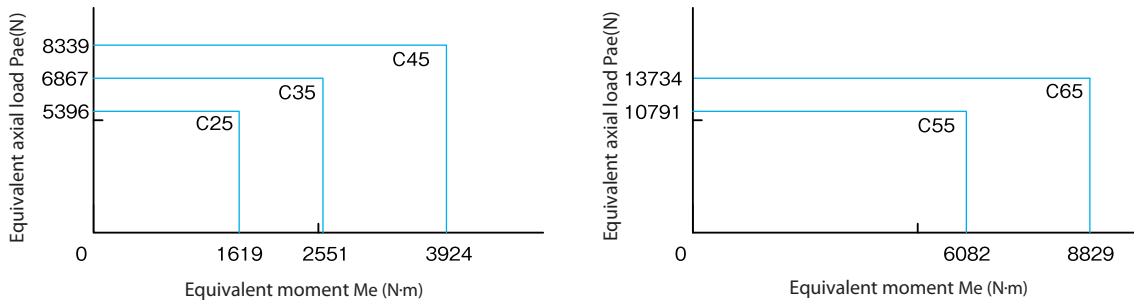
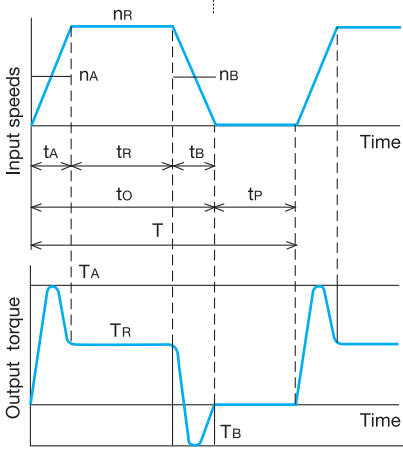

Fig. C-14 Diagram of Allowable Moment & Axial Load

# 10. Selection

## 10-1. Flow Cart and Formula of Selection

FIG. C-15 Load cycle



$n_A$  : Average input speed during acceleration under condition defined in Fig. C-15

$$n_A = \frac{n_R}{2}$$

$n_R$  : Input speed with normal running

$n_B$  : Average input speed during deceleration in Fig. C-15

$$n_B = \frac{n_R}{2}$$

$t_A$  : Acceleration time  
 $t_R$  : Normal running time  
 $t_B$  : Deceleration time  
 $t_o$  : Total running time  
 $t_P$  : Standstill time  
 $T$  : Time/Cycle  
 $T_A$  : Acceleration peak torque  
 $T_R$  : Torque during normal running  
 $T_B$  : Peak torque at braking

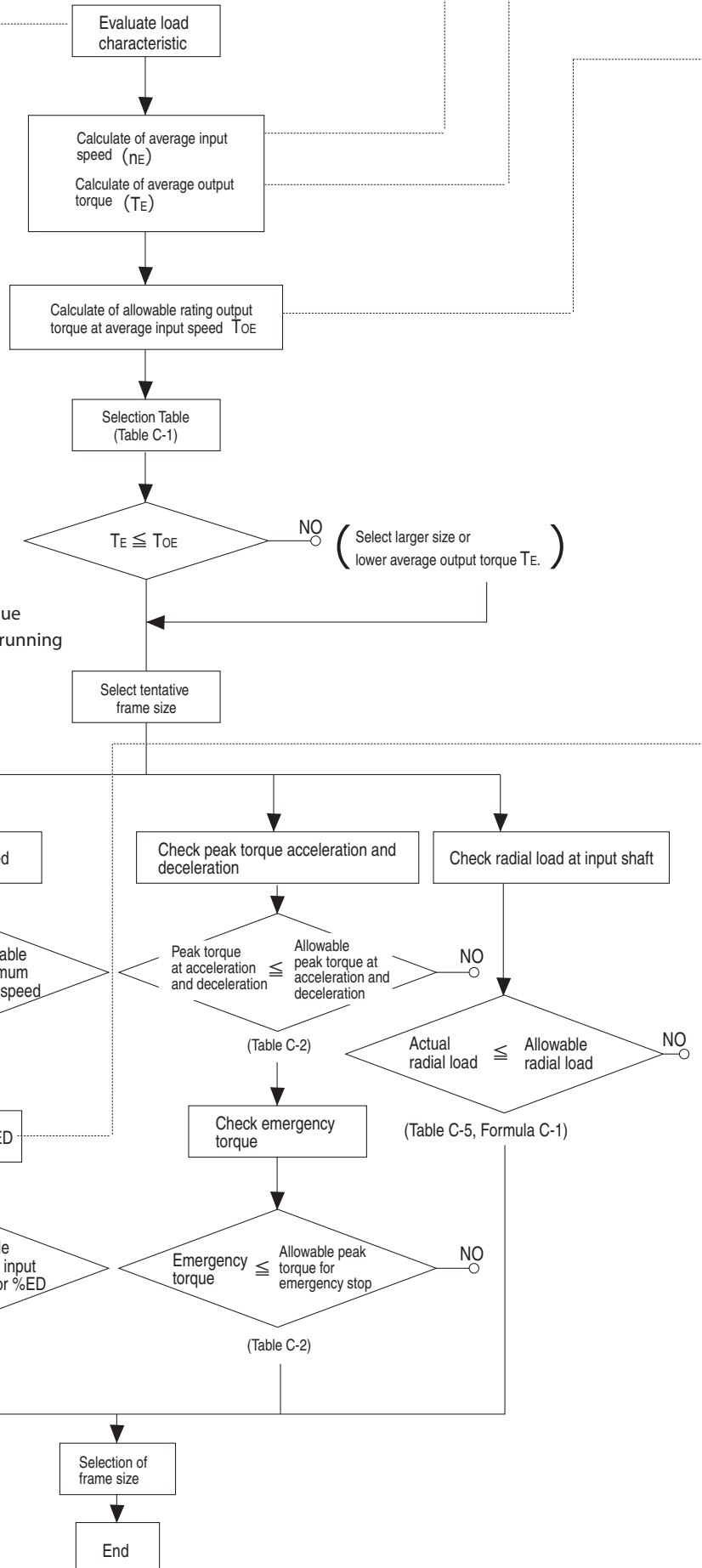

Calculation in Load Condition of Fig. C-15

○ Average input speed  $n_E = \left( \frac{t_A n_A + t_R n_R + t_B n_B}{t_o} \right)$  ..... (Formula C-8)

○ Average output torque  $T_E = \left( \frac{t_A n_A T_A^{10/3} + t_R n_R T_R^{10/3} + t_B n_B T_B^{10/3}}{t_o} \right)^{0.3} \times F_{S2}$  ..... (Formula C-9)

○ Allowable rating output torque at average input speed  $T_{OE} = \left( \frac{600}{n_E} \right)^{0.3} \times T_o$  ..... (Formula C-10)

To: Rated output torque at input speed 600r/min (Table C-2)

When  $n_E < 600$ ,  $T_{OE}$  equals to  $T_o$  at input speed 600r/min.

○ %ED  $\%ED = \frac{t_o}{T} \times 100$  ..... (Formula C-11)

Maximum of single cycle time is 10 minutes when calculating %ED. When single cycle time is over 10 minutes, calculate %ED as T=10 (minutes).

Table C-15  $F_{S2}$  Load factor

Loading condition	$F_{S2}$
Uniform load	1
Moderate shock	11.2
Heavy shock	1.41.6

10-2. Example of Selection

0 Evaluate F2C-C25-119 for following specification.

(Specification) $T_A$ : Acceleration peak torque	600N·m	$t_A$ : Acceleration time	0.3sec
$T_R$ : Normal running torque	250N·m	$t_R$ : Normal running time	3.0sec
$T_B$ : Peak torque at breaking	400N·m	$t_B$ : Deceleration time	0.3sec
Emergency torque : 1700N·m		$t_P$ : Total running time	3.6sec
(1000 times during overall life time)		$t_o$ : Standstill time	3.6sec
$n_A$ : Average input speed during acceleration	1250r/min	$T$ : Single cycle time	7.2sec
$n_R$ : Input speed with normal running	2500r/min	Radial load at input shaft	: Operated by timing belt with moderate shock 196N at point 25mm from end of shaft
$n_B$ : Average input speed during deceleration	1250r/min	Radial load at output shaft	: Connection with gear, moderate shock 4116N at 60mm point from side of flange

It considered that reducer is used to operate wrist of robot with moderate shock.

(Calculate) Average input speed  $n_E = \frac{0.3 \times 1250 + 3.0 \times 2500 + 0.3 \times 1250}{3.6} = 2292(r/min)$

Average output torque  $T_E = \left( \frac{0.3 \times 1250 \times 600^{10/3} + 3.0 \times 2500 \times 250^{10/3} + 0.3 \times 1250 \times 400^{10/3}}{3.6 \times 2292} \right)^{0.3} \times 1 = 306(N·m)$

○ Allowable output torque at average input speed  $T_{OE} = \left( \frac{600}{2292} \right)^{0.3} \times 568 = 380(N·m) \geq 306(N·m) \rightarrow F2C-C25-119$

○ Calculate of %ED  $\%ED = \frac{3.6}{7.2} \times 100 = 50\%$

○ Evaluate of maximum input speed 2500(r/min) < 3500(r/min) (Table C-1)

○ Evaluate of average input speed 2292(r/min) at 50%ED < 2900(r/min) at 50%ED (Table C-1)

○ Evaluate of peak torque at acceleration and deceleration 600(N·m) < 1030(N·m) (Table C-2)

○ Evaluate of emergency torque 1700(N·m) < 2060(N·m) (Table C-2)

○ Allowable radial load at input shaft with coefficient in consideration

$Pro = 538N = 841 \times (600/2292)^{1/3}$ ,  $Lf = 1.14$ ,  $Cf = 1.25$ ,  $F_{S1} = 1.2$

$\frac{Pro}{Lf \times Cf \times F_{S1}} = \frac{538}{1.14 \times 1.25 \times 1.2} = 315(N) > 196(N)$  (Table C-5, Formula C-1)

○ Evaluate of allowable moment

$Lr = 55 + L1 - a = 55 + 102 - 13.5 = 143.5mm$

External Moment Calculated with the Coefficient

$Cf = 1.25$ ,  $F_{S1} = 1.2$ ,  $M = Cf \times F_{S1} \times Pr \times Lr = 1.25 \times 1.2 \times 4116 \times 143.5 \times 10^{-3} = 886(N·m) < 1619(N·m)$

F2C-C25-119 is selected by evaluation above.

# 11. Notice for Designing

## 11-1 Precision in Assembly Dimensions

Fig. C-16 Method of Assembly

- Pilot for mounting input parts(Pully, Gear etc.) are as (C) in following figure.
- Use (B) for output shaft assembly and (A) for casing assembly as pilot for mounting.

Example for Assembly 1

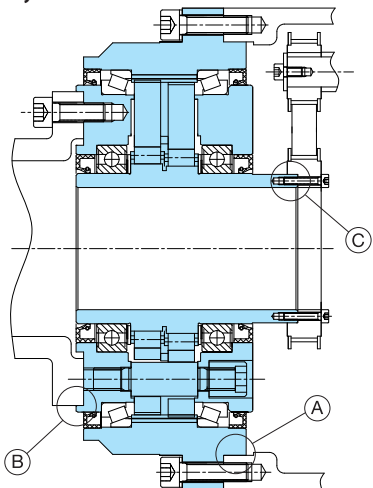

## 11-2. Tightening Torque and Allowable Transmitted Torque for Bolts

1 Allowable transmitted torque for bolts

Quantity, size, and tightening torque of bolt for the output flange and ring gear housing are shown in Table C-16. Allowable peak torque for emergency stop that can be transmitted is shown in Table C-16.

Table C-16

Frame size	Output Flange Bolts					Ring gear housing bolts				
	Number of bolts-size	Tightening torque		Allowable transmitted torque by bolts		Number of bolts-size	Tightening torque		Allowable transmitted torque by bolts	
		N·m	kgf·cm	N·m	kgf·m		N·m	kgf·cm	N·m	kgf·m
F2C-C25	12-M8	33.4	340	2080	212	12-M8	33.4	340	3178	324
F2CF-C35	12-M10	65.7	670	4267	435	8-M10	65.7	670	4670	476
F2CF-C45	12-M12	114	1160	7191	733	8-M12	114	1160	7760	791
F2CF-C55	12-M14	181	1850	10919	1113	12-M12	114	1160	1308	1326
F2CF-C65	12-M16	284	2890	16893	1722	16-M16	114	1160	19404	1978

Frame size	Eccentric High Speed Shaft				
	Number of bolts-size	Tightening torque		Allowable transmitted torque by bolts	
		N·m	kgf·cm	N·m	kgf·m
F2C-C25	6-M3	1.67	17	69	7.0
F2CF-C35	6-M4	3.92	40	157	16
F2CF-C45	6-M4	3.92	40	196	20
F2CF-C55	8-M5	8.04	82	481	49
F2CF-C65	12-M5	8.04	82	785	80

- Bolt: Use metric hexagon socket head cap screw based on JIS B1176, strength grade 10.9"
- Countermeasure for bolts loosening: Use adhesives (Loctite262, etc.) or spring washer (based on JIS B1251, class 2).
- Use conical spring washer (Based on JIS B1251, class 2) on flange side when coupling the reducer to prevent damaging the bolt bearing surface.
- Friction Coefficient: 0.15

### 11-3. Assembly Procedure

Example for Assembly 1

(1)

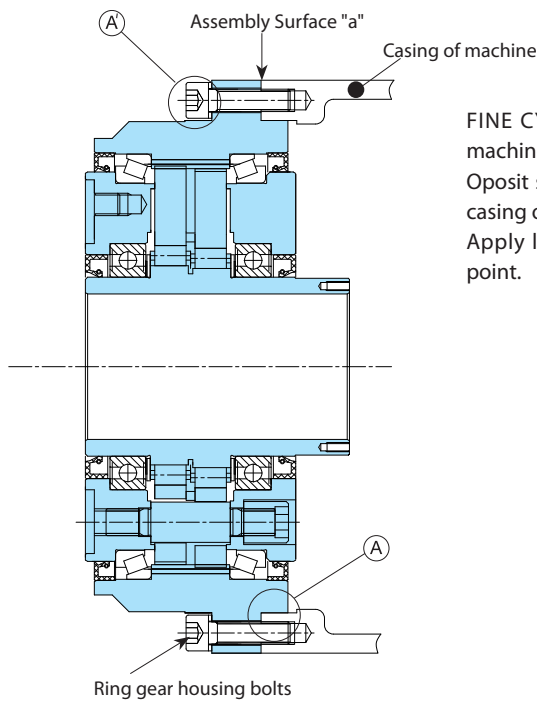

FINE CYCLO® F-Series is attached to the casing of machine with bolts.(Pilot (A))  
 Oposit side (Pilot (A)) can be used for attaching to the casing of machine.  
 Apply liquid gasket to the assembly side "a" at this point.

(2)

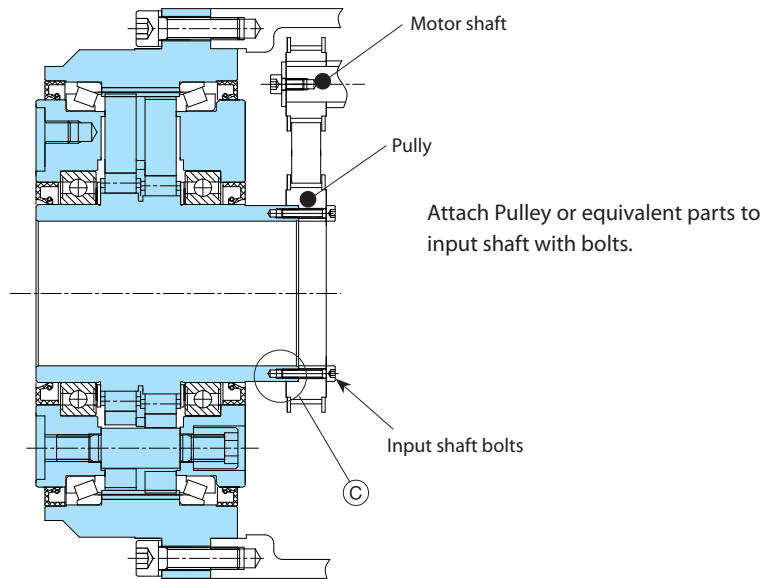

Attach Pully or equivalent parts to input shaft with bolts.

(3)

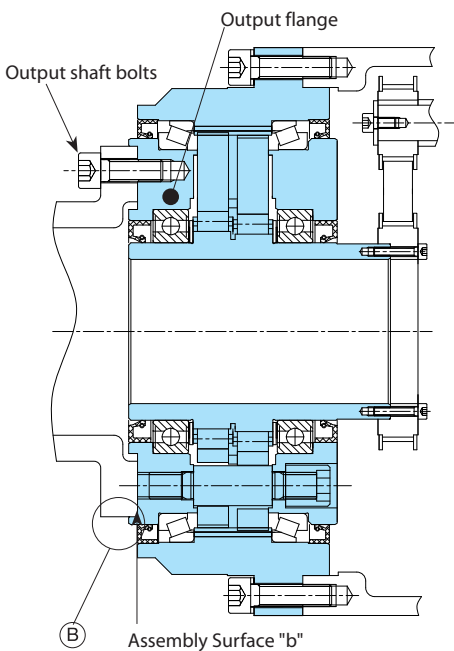

Attach Output flange of FINE CYCLO to output shaft of machine by bolts.(Pilot (B))  
 Apply liquid gasket to the assembly side "b" at this point.

Notes1) Make sure to apply specified tightening torque( refer to Table C-16) to bolts when attaching reducer.

Notes2) Choose bolts shorter then the depth of tap indicated in output side flange and input shaft in Outline Drawing.

Recommended liquid gasket: Liquid gasket Three Bond 1215 of Three Bond Co., Ltd.

### 11-4. Lubrication

- Grease supply at the time of assembly is not necessary. FINE CYCLO® is filled with grease (Multemp FZ No. 00) before shipment to customer.
- Overhaul recommended when reducer runs for total 20000 hours or 3-5 years after purchase.
- Overhaul requires experience and technique. F-CYCLO must be sent to SHI-factory.
- Condition of use: Ambient temperture -10 - +40 Ceisius Degree.

Table C-18

Unit: g

Frame size	C25	C35	C45	C55	C65
Grease(g)	75	110	140	200	300



# 12. Outline Drawing

## F2C-C25

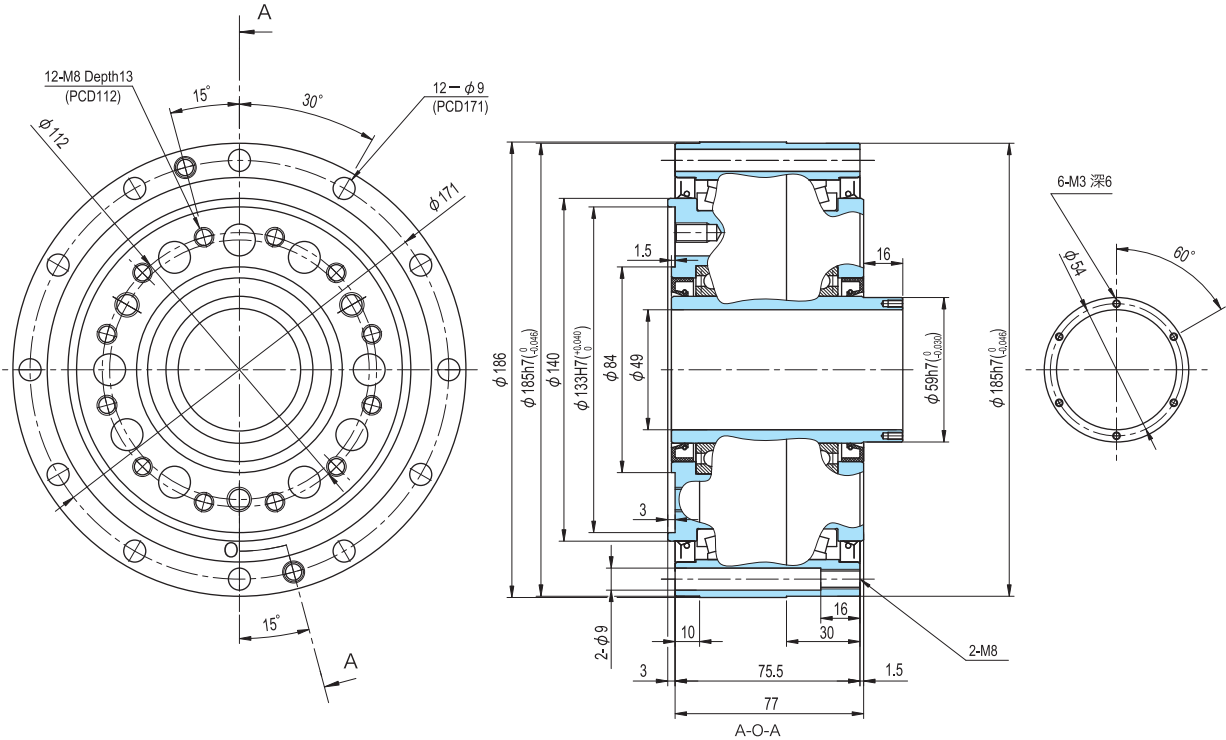

Mass 12.5kg

## F2CF-C35

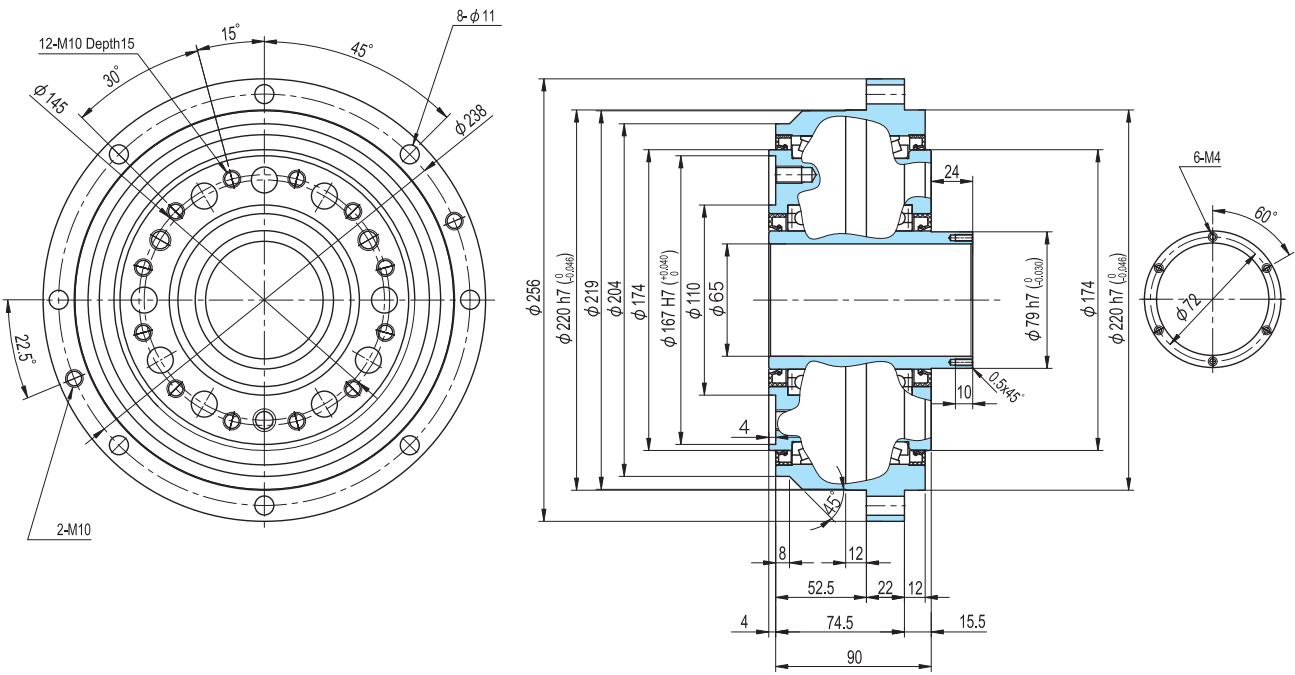

Mass 21kg

# Outline Drawing

## F2CF-C45

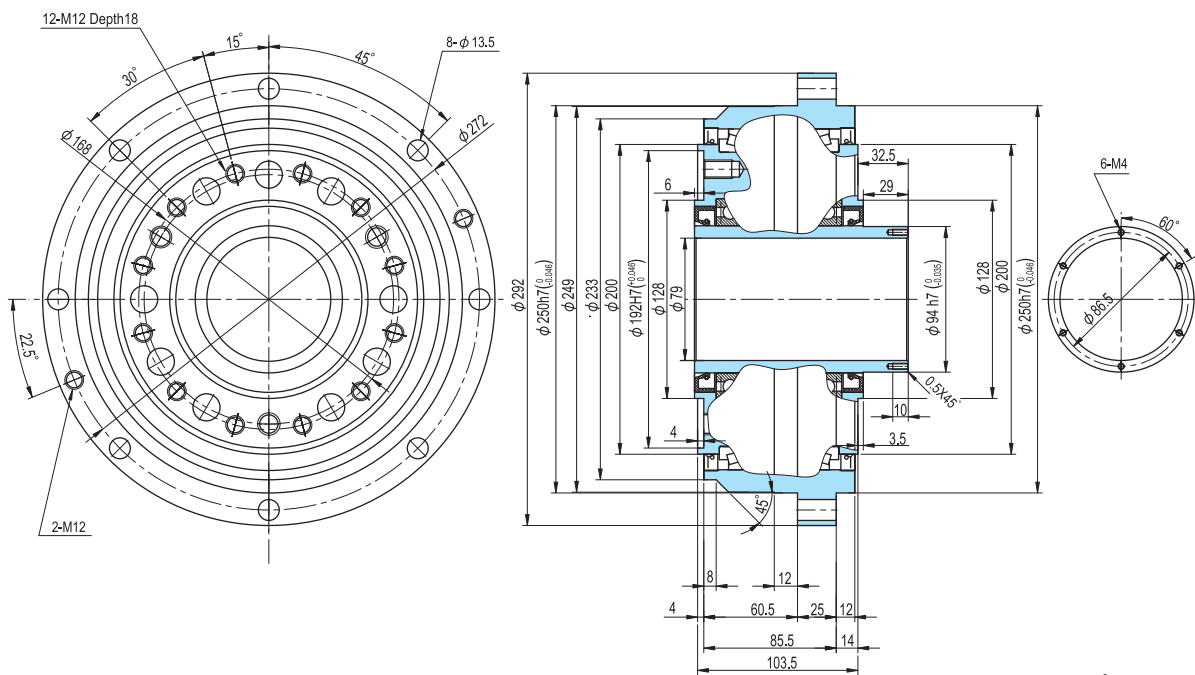

Mass 32kg

## F2CF-C55

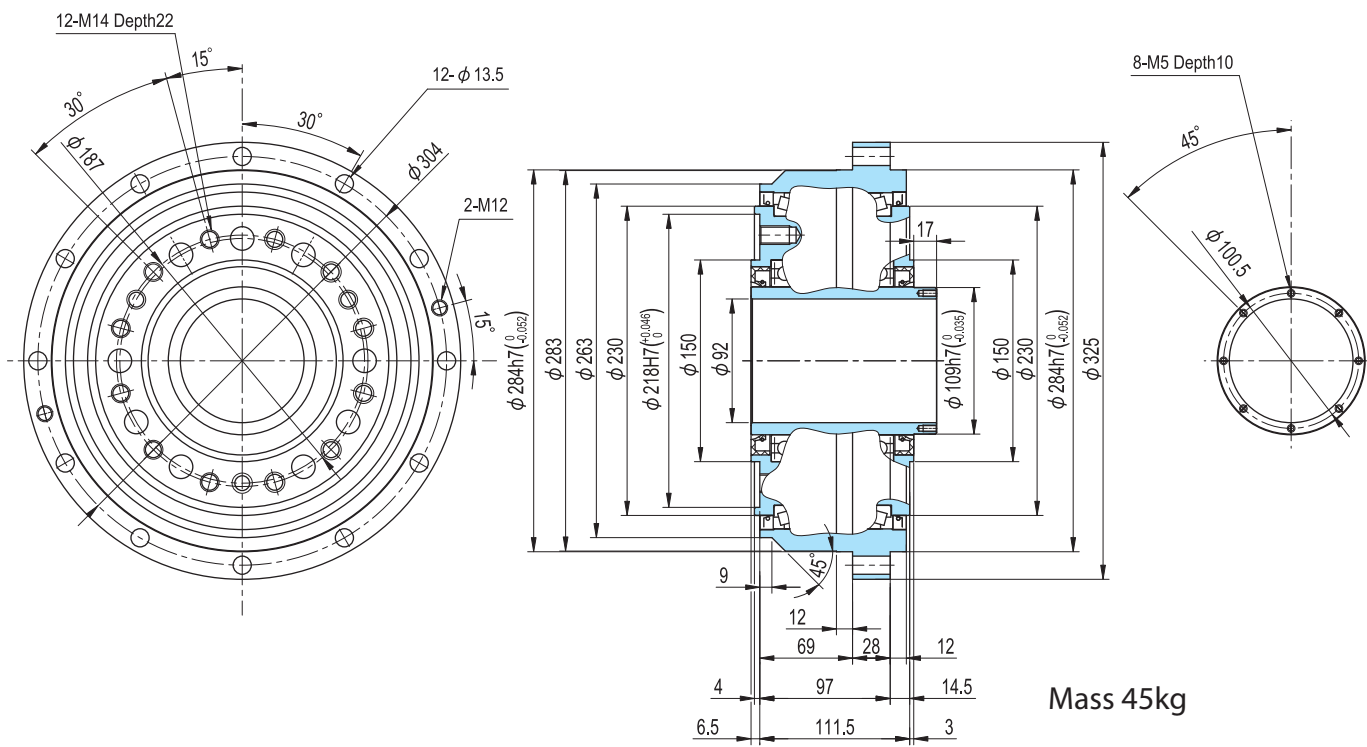

Mass 45kg

# Outline Drawing

F2CF-C65

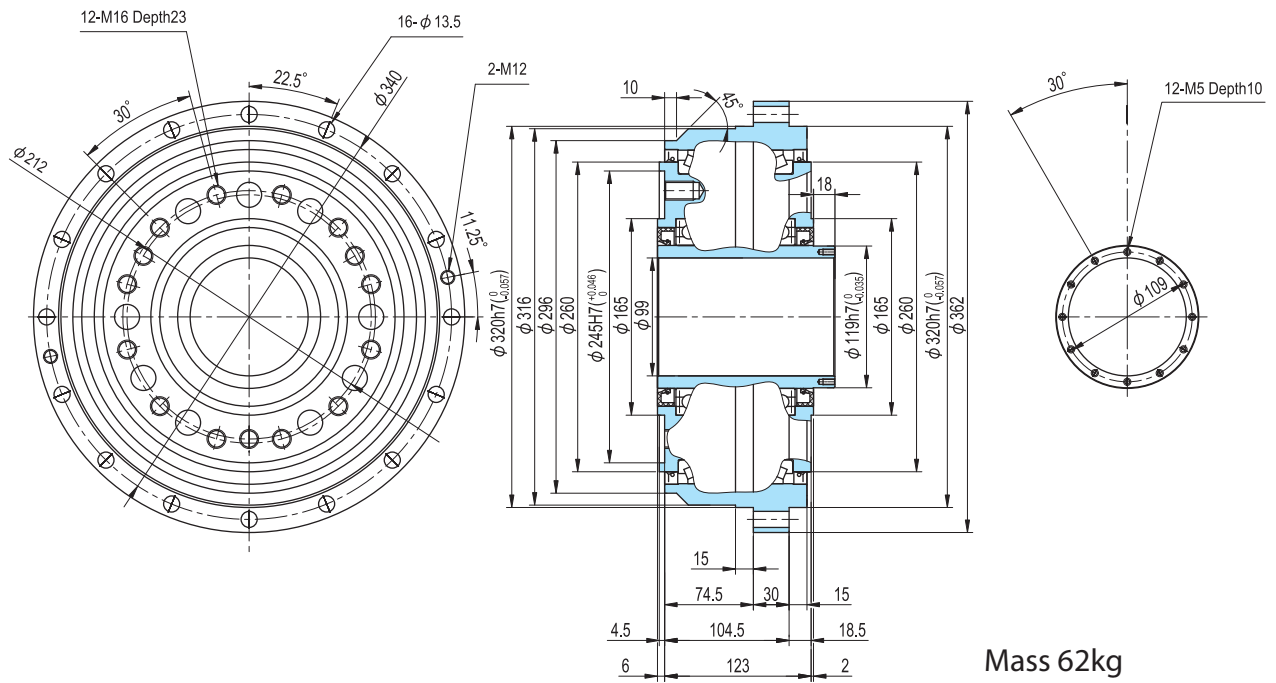

# Worldwide locations

## World Headquarters JAPAN

Sumitomo Heavy Industries Ltd.  
PTC Group  
Think Park Tower, 1-1,  
Osaki 2-chome,  
Shinagawa-ku, Tokyo 141-6025  
[www.cyclo.shi.co.jp](http://www.cyclo.shi.co.jp)

## Headquarters & Manufacturing EUROPE

### Germany

Sumitomo (SHI) Cyclo Drive Germany GmbH  
European Headquarters  
Cyclostraße 92  
85229 Markt Indersdorf  
Germany  
Tel. +49 (0) 81 36 66-0  
Fax +49 (0) 81 36 57 71  
E-Mail: [marktind@sce-cyclo.com](mailto:marktind@sce-cyclo.com)  
[www.sumitomodriveeurope.com](http://www.sumitomodriveeurope.com)

## Subsidiaries & Sales Offices in Europe

### Austria

Sales Office Austria  
Gruentalerstraße 30 A  
4020 Linz  
Austria  
Tel. +43 (0) 732 33 09 58  
Fax +43 (0) 732 33 19 78

### Benelux

Sales Office Benelux  
Heikneuterlaan 23  
3010 Kessel-Lo/ Leuven  
Belgium  
Tel. +32 (0) 16 60 83 11  
Fax +32 (0) 16 57 16 39

### France

SM-Cyclo France S.A.R.L.  
8 Avenue Christian Doppler  
Arlington Techniparc  
77700 Serris  
France  
Tel. +33 (0) 149 92 94 94  
Fax +33 (0) 149 92 94 90

### Italy

SM-Cyclo Italy S.R.L.  
Via dell'Artigianato 23  
20010 Cornaredo (MI)  
Italy  
Tel. +39 (0) 2 93 56 21 21  
Fax +39 (0) 2 93 56 98 93

## Headquarters & Manufacturing USA

Sumitomo Drive Technologies  
Sumitomo Machinery Corp. of America  
4200 Holland Boulevard  
Chesapeake, VA 23323  
Tel. +1 (757) 4 85 33 55  
Fax +1 (757) 4 87 31 93  
[www.smcyclo.com](http://www.smcyclo.com)

### Spain

SM-Cyclo Iberia  
Edificio Gobelas  
C/Landabbarri no. 4  
Escalera 1 – 2.º Izqda  
48940 Leioa, Vizcaya  
Spain  
Tel. +34 (0) 94 48 05 38 9  
Fax +34 (0) 94 48 01 55 0

### Sweden

SM-Cyclo Scandinavia AB  
Ridbanegatan 4  
21377 Malmö  
Sweden  
Tel. +46 (0) 40 22 00 30  
Fax +46 (0) 40 22 00 35

### United Kingdom

SM-Cyclo UK, Ltd.  
Unit 29, Bergen Way,  
Sutton Fields Industrial Estate  
Kingston upon Hull  
HU7 0YQ, East Yorkshire  
United Kingdom  
Tel. +44 (0) 14 82 79 03 40  
Fax +44 (0) 14 82 79 03 21