

Sumitomo Drive Technologies
Always on the Move

PARAMAX[®] SPA Series
Single Stage Drives

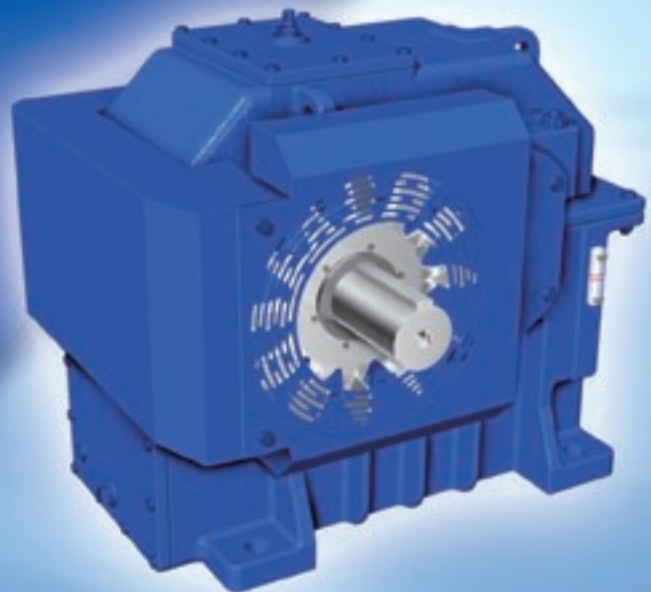

No. G2003E-2

Features

- **Varied reduction ratios**

17 varieties of reduction ratios are available for each size. Customers can select desired reduction ratios from among our standard lineup of reducer sizes.

- **Long-life bearing for minimum maintenance**

The design life of the bearing (L10) is 100,000 hours or longer.

- **Dedicated housing with large capacity**

The capacity of the lower housing is secured to reduce deterioration of the lubricants.

- **Various cooling systems with high cooling performance**

Desired operating temperatures can be attained by the combined use of the large housing with the cooling fan and cooling coil.

- **Ease of maintenance**

The cooling coil integrated with the cover can be attached or detached without disassembling the housing. Since all housings are of split type, the replacement of the internal parts during overhaul is locally available.

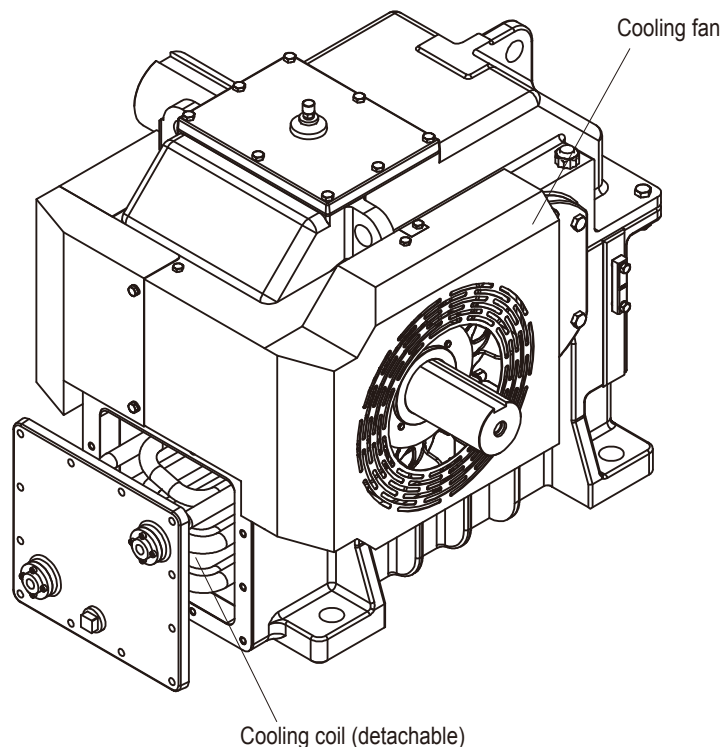

Nomenclature, Specifications, Lubrication, Paint

Nomenclature

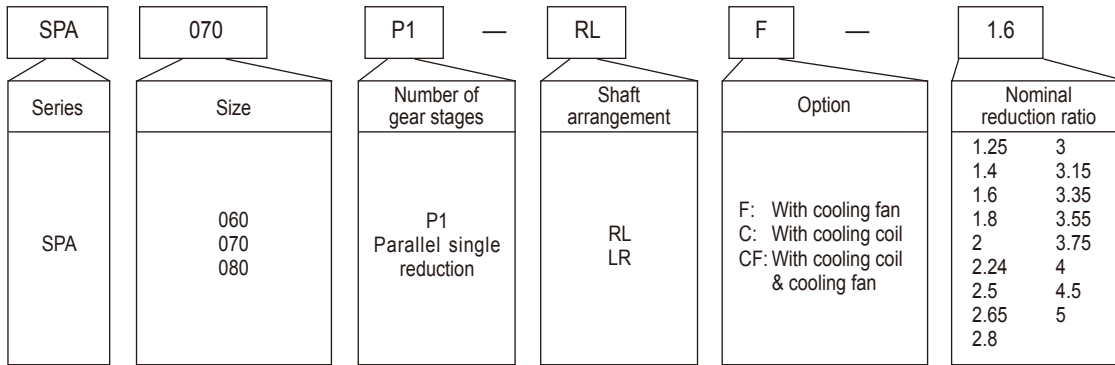

Standard Specifications

Item		Standard Specifications
Reducer	Gear	Material: Alloy steel Heat treatment: Carburizing and quenching Process: Precise finish
	Bearing	Type: Anti-friction bearing Rated life (L10): 100,000 hours or more
	Shaft	Material: Alloy steel
	Housing	Material: Cast iron
	Lubricants	Oil bath
Ambient Condition	Ambient Temp.	0°C to 40°C (Ambient temperature shall be at temperatures near the reducer.)
	Atmosphere	Free of corrosive and explosive gases.
Connection methods		Inline Coupling (Consult Factory for other methods of connections)

Recommended Lubricants

Slow speed shaft speed 100r/min or more

	Ambient Temperature		
	-10°C to +15°C	0°C to 30°C	10°C to 50°C
ISO	VG68	VG150	VG220
AGMA	2EP	4EP	5EP

Viscosity Class Gear Oil	BP	CASTROL			CHEVRON TEXACO		EXXON MOBIL		SHELL	TORAL
	ISO VG68 AGMA 2EP	ENERGOL GR-XP-68	ALPHA SP68	OPTIGEAR BM68	TRIBOL 1100/68	GEAR COMPOUNDS EP68	MEROPA WM68	SPARTAN EP68	MOBILGEAR 626	OMALA 68
ISO VG150 AGMA 4EP	ENERGOL GR-XP-150	ALPHA SP150	OPTIGEAR BM150	TRIBOL 1100/150	GEAR COMPOUNDS EP150	MEROPA WM150	SPARTAN EP150	MOBILGEAR 629	OMALA 150	CARTER EP150
ISO VG220 AGMA 5EP	ENERGOL GR-XP-220	ALPHA SP220	OPTIGEAR BM220	TRIBOL 1100/220	GEAR COMPOUNDS EP220	MEROPA WM220	SPARTAN EP220	MOBILGEAR 630	OMALA 220	CARTER EP220

Painting Specifications

Painting Area	Surface Conditioning	Kind of Painting Painting of Finish Coat	Painting Specifications			
			Type	Coating	Film Thickness μm	Type of Coating
Outside Painting	Cast Iron Class 1	Acrylic modified phthalic	Under	2	40 to 80	Modified alkyd resin
			Finish	1	15 to 30	Acrylic modified alkyd resin
Inside Painting	Cast Iron Class 1 Steel Plate Class 3	—	—	1	20 to 40	Modified alkyd resin

Selection Table

Rated Power (kW)

Condition: Service Factor 2.0

Nominal Ratio	High Speed Shaft Speed r/min	Size		
		060	070	080
1.25	1800	1171	1818*	2472*
	1500	1030	1515	2175*
	1200	856	1212	1740
	1000	713	1010	1450
1.4	1800	1099	1900	2245
	1500	967	1515	1976
	1200	827	1212	1690
	1000	713	1010	1450
1.6	1800	990	1714	2260
	1500	872	1509	1989
	1200	746	1212	1701
	1000	656	1010	1450
1.8	1800	955	1594	2187
	1500	841	1403	1925
	1200	719	1194	1620
	1000	633	1003	1389
2	1800	883	1473	2032
	1500	778	1297	1788
	1200	665	1070	1517
	1000	585	898	1274
2.24	1800	811	1353	1862
	1500	714	1158	1639
	1200	610	935	1325
	1000	533	785	1113
2.5	1800	738	1292	1779
	1500	649	1086	1539
	1200	551	877	1243
	1000	463	736	1044
2.65	1800	728	1101	1684
	1500	641	925	1415
	1200	519	747	1143
	1000	435	627	960
2.8	1800	697	1097	1552
	1500	599	921	1304
	1200	483	744	1054
	1000	405	624	885

Nominal Ratio	High Speed Shaft Speed r/min	Size		
		060	070	080
3	1800	662	1006	1423
	1500	556	845	1196
	1200	448	682	966
	1000	376	572	811
3.15	1800	626	952	1383
	1500	525	799	1162
	1200	424	645	938
	1000	355	541	787
3.35	1800	570	865	1258
	1500	478	727	1057
	1200	386	586	853
	1000	323	492	716
3.55	1800	520	791	1149
	1500	437	664	965
	1200	295	536	779
	1000	295	449	654
3.75	1800	473	726	1057
	1500	397	610	888
	1200	320	492	716
	1000	268	412	601
4	1800	474	729	1060
	1500	398	612	890
	1200	321	494	718
	1000	269	414	603
4.5	1800	416	616	847
	1500	349	517	711
	1200	281	417	574
	1000	236	349	481
5	1800	340	469	700
	1500	283	391	587
	1200	227	312	474
	1000	189	260	397

Note: kW with "*" mark requires forced lubrication system.

Exact Reduction Ratio

Nominal Ratio	Size		
	060	070	080
1.25	1.250	1.250	1.281
1.4	1.400	1.400	1.433
1.6	1.630	1.571	1.571
1.8	1.769	1.769	1.808
2	2.000	2.000	2.042
2.24	2.273	2.273	2.318
2.5	2.550	2.429	2.476
2.65	2.652	2.737	2.650
2.8	2.818	2.789	2.842
3	3.000	3.000	3.056
3.15	3.200	3.150	3.150
3.35	3.421	3.368	3.368
3.55	3.667	3.611	3.611
3.75	3.941	3.824	3.824
4	4.000	3.882	3.882
4.5	4.368	4.389	4.588
5	5.000	5.105	5.111

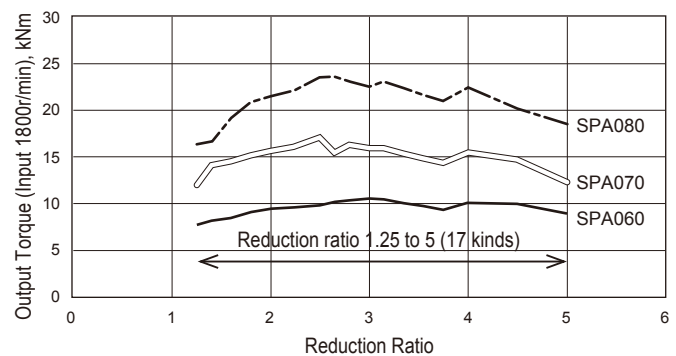

Figure Reduction ratio and approx. output torque (Service Factor 2)

Selection Table

Thermal Rating (Gearbox surface temp at 70°C) Unit: kW

C: With cooling coil
CF: With cooling coil & cooling fan

Nominal Ratio	Ambient Temperature	20°C						40°C					
	Size	060		070		080		060		070		080	
	High Speed Shaft Speed r/min	C	CF	C	CF	C	CF	C	CF	C	CF	C	CF
1.25	1800	*	*	*	*	*	*	*	*	*	*	*	*
	1500	*	875	*	1001	*	1050	*	*	*	395	*	*
	1200	730	1243	811	1508	742	1754	547	874	564	1007	383	1027
	1000	1025	1404	1217	1729	1317	2062	853	1094	984	1310	978	1452
1.4	1800	*	*	*	*	*	*	*	*	*	*	*	*
	1500	265	934	*	1075	*	1154	*	*	*	488	*	*
	1200	769	1266	861	1535	816	1794	593	909	622	1051	470	1092
	1000	1041	1407	1236	1732	1349	2069	875	1107	1011	1326	1022	1480
1.6	1800	*	*	*	*	*	*	*	*	*	*	*	*
	1500	379	1016	*	1145	*	1255	*	*	*	585	*	423
	1200	825	1299	908	1552	889	1845	656	958	679	1089	550	1158
	1000	1065	1414	1248	1722	1390	2093	906	1128	1032	1334	1070	1518
1.8	1800	*	*	*	*	*	*	*	*	*	*	*	*
	1500	314	926	*	1090	*	1231	*	*	*	552	*	451
	1200	728	1184	833	1451	836	1731	567	856	614	1007	519	1088
	1000	952	1287	1144	1598	1276	1935	799	1013	937	1226	977	1396
2	1800	*	704	*	785	*	831	*	*	*	184	*	*
	1500	397	970	381	1159	*	1345	235	*	*	656	*	616
	1200	756	1182	879	1457	920	1757	605	876	674	1042	623	1156
	1000	948	1261	1147	1572	1299	1914	806	1005	954	1224	1019	1411
2.24	1800	*	815	*	944	*	1033	*	*	*	373	*	*
	1500	488	1032	511	1250	390	1460	334	*	302	772	*	768
	1200	798	1201	942	1490	1004	1798	654	911	747	1096	722	1227
	1000	962	1258	1171	1574	1333	1917	827	1016	988	1244	1068	1439
2.5	1800	*	870	*	972	*	1083	*	*	*	431	*	*
	1500	541	1041	543	1244	448	1462	399	717	345	791	*	806
	1200	801	1172	936	1456	1007	1759	669	905	751	1082	740	1219
	1000	937	1211	1144	1526	1306	1859	813	987	970	1213	1055	1406
2.65	1800	*	735	*	1053	*	1153	*	*	*	538	*	385
	1500	373	928	613	1279	505	1499	216	569	424	848	*	856
	1200	667	1079	959	1453	1031	1768	521	783	783	1098	770	1239
	1000	824	1127	1141	1504	1311	1853	687	880	976	1207	1065	1410
2.8	1800	*	766	*	1063	*	1216	*	*	*	554	*	479
	1500	403	938	622	1281	567	1521	252	592	436	855	297	904
	1200	675	1072	959	1447	1049	1756	534	787	786	1096	798	1248
	1000	819	1111	1136	1494	1304	1824	687	872	973	1201	1068	1399
3	1800	*	794	281	1098	*	1273	*	*	*	611	*	568
	1500	432	946	657	1287	625	1538	286	613	479	879	367	947
	1200	681	1062	962	1429	1063	1739	545	788	796	1094	823	1253
	1000	813	1093	1121	1464	1294	1790	685	864	965	1184	1068	1384
3.15	1800	174	795	346	1190	*	1362	*	*	*	687	*	634
	1500	444	923	722	1372	683	1625	308	613	537	951	415	1015
	1200	665	1020	1026	1509	1126	1825	539	765	855	1162	877	1322
	1000	781	1042	1185	1539	1359	1873	662	828	1024	1249	1126	1453
3.35	1800	228	839	415	1243	*	1437	*	*	*	750	*	724
	1500	480	951	766	1404	746	1669	346	646	585	991	485	1072
	1200	686	1035	1049	1522	1158	1843	562	784	881	1182	916	1351
	1000	793	1050	1195	1542	1375	1877	677	840	1037	1258	1146	1466
3.55	1800	366	948	327	1117	*	1315	230	*	*	646	*	633
	1500	589	1038	650	1259	637	1519	462	748	478	865	388	949
	1200	769	1102	912	1363	1018	1671	651	863	752	1039	786	1202
	1000	862	1106	1048	1379	1217	1697	751	906	897	1108	999	1305
3.75	1800	402	955	372	1130	244	1345	273	626	196	678	*	689
	1500	602	1028	669	1253	674	1522	481	752	503	875	433	973
	1200	761	1077	908	1341	1023	1652	649	850	754	1030	800	1200
	1000	843	1074	1032	1349	1206	1668	738	885	887	1089	997	1290
4	1800	397	929	373	1103	255	1316	273	612	203	668	*	684
	1500	586	996	655	1217	664	1481	470	731	495	853	433	952
	1200	737	1040	882	1298	996	1600	630	823	734	999	781	1166
	1000	814	1035	998	1304	1168	1612	713	854	860	1054	967	1249
4.5	1800	488	1052	500	1243	460	1489	357	716	327	800	221	876
	1500	675	1110	759	1332	807	1599	551	828	597	962	582	1087
	1200	823	1145	967	1391	1086	1673	709	914	817	1087	877	1251
	1000	898	1134	1073	1384	1229	1659	790	940	932	1129	1033	1307
5	1800	570	1118	644	1388	601	1648	443	791	471	945	358	1024
	1500	730	1152	873	1447	924	1731	610	879	710	1075	695	1209
	1200	856	1168	1054	1479	1183	1781	745	944	903	1173	970	1351
	1000	917	1146	1144	1456	1314	1753	813	959	1003	1201	1115	1394

Notes: 1. Coolant spec requirements: Temp 20°C, Flow rate: 5 liter/min.

2. "*" mark requires external cooler unit instead of cooling coil. Consult Factory for the detail of required cooler unit.

Selection Table

Thermal Rating (Gearbox surface temp at 90°C) Unit: kW

C: With cooling coil
 CF: With cooling coil & cooling fan

Nominal Ratio	Ambient Temperature	20°C						40°C					
	Size	060		070		080		060		070		080	
	High Speed Shaft Speed r/min	C	CF	C	CF	C	CF	C	CF	C	CF	C	CF
1.25	1800	1189	2409	1345	3001	1284	3694	981	1876	1063	2278	874	2641
	1500	1615	2557	1932	3209	2122	3980	1419	2110	1666	2603	1736	3098
	1200	1946	2647	2390	3340	2783	4163	1764	2278	2143	2839	2424	3436
	1000	2109	2624	2617	3316	3115	4130	1937	2315	2383	2896	2776	3521
1.4	1800	1243	2423	1413	3015	1389	3717	1042	1908	1140	2315	992	2700
	1500	1633	2545	1955	3191	2163	3958	1444	2112	1698	2604	1790	3106
	1200	1936	2614	2376	3295	2772	4105	1760	2257	2137	2811	2425	3402
	1000	2083	2582	2583	3259	3075	4057	1916	2282	2357	2853	2748	3468
1.6	1800	1318	2443	1476	3008	1490	3762	1126	1952	1215	2339	1103	2770
	1500	1661	2531	1965	3147	2215	3969	1480	2118	1719	2586	1851	3137
	1200	1925	2572	2343	3221	2785	4088	1756	2231	2115	2759	2446	3401
	1000	2051	2527	2526	3173	3068	4027	1892	2241	2311	2785	2748	3452
1.8	1800	1169	2251	1355	2825	1398	3529	985	1778	1105	2183	1035	2598
	1500	1489	2324	1802	2935	2035	3679	1315	1928	1566	2397	1694	2899
	1200	1735	2356	2147	2989	2534	3755	1573	2029	1928	2546	2216	3111
	1000	1852	2309	2314	2934	2780	3678	1700	2035	2108	2562	2481	3139
2	1800	1204	2216	1415	2791	1512	3505	1031	1774	1181	2190	1173	2634
	1500	1477	2259	1799	2860	2058	3595	1315	1888	1578	2357	1739	2866
	1200	1685	2266	2092	2880	2481	3622	1534	1960	1887	2465	2185	3021
	1000	1782	2209	2231	2811	2687	3526	1640	1953	2038	2463	2407	3022
2.24	1800	1260	2221	1501	2807	1629	3521	1097	1801	1279	2237	1306	2694
	1500	1493	2235	1828	2836	2102	3560	1339	1883	1619	2358	1798	2868
	1200	1667	2217	2075	2822	2464	3546	1523	1927	1880	2428	2182	2976
	1000	1745	2150	2188	2738	2635	3431	1610	1907	2005	2408	2370	2954
2.5	1800	1257	2142	1487	2726	1627	3420	1106	1755	1276	2185	1321	2636
	1500	1450	2133	1783	2739	2055	3437	1308	1809	1584	2285	1768	2781
	1200	1591	2098	2004	2713	2381	3406	1459	1831	1820	2340	2114	2866
	1000	1652	2025	2104	2625	2533	3287	1528	1801	1930	2313	2282	2835
2.65	1800	1059	2038	1514	2692	1659	3417	892	1610	1313	2177	1360	2649
	1500	1282	2039	1771	2680	2060	3415	1125	1680	1583	2249	1778	2772
	1200	1452	2014	1962	2636	2363	3368	1306	1718	1786	2281	2101	2838
	1000	1531	1944	2046	2541	2503	3242	1393	1696	1880	2244	2257	2799
2.8	1800	1067	2012	1515	2679	1680	3367	907	1599	1316	2171	1392	2630
	1500	1272	2002	1764	2662	2044	3344	1121	1656	1578	2236	1774	2728
	1200	1427	1969	1948	2614	2317	3281	1286	1683	1775	2263	2066	2773
	1000	1498	1896	2027	2516	2441	3150	1365	1657	1864	2223	2205	2725
3	1800	1073	1982	1515	2630	1695	3310	919	1585	1325	2143	1420	2604
	1500	1260	1962	1739	2598	2024	3267	1115	1629	1561	2191	1765	2677
	1200	1400	1920	1902	2538	2267	3189	1264	1646	1736	2203	2027	2703
	1000	1462	1844	1970	2437	2375	3052	1335	1615	1814	2157	2149	2646
3.15	1800	1045	1892	1609	2760	1789	3456	901	1522	1414	2257	1505	2728
	1500	1209	1863	1832	2720	2121	3407	1074	1553	1648	2299	1854	2797
	1200	1330	1815	1993	2651	2367	3321	1204	1560	1822	2305	2119	2818
	1000	1383	1739	2061	2544	2476	3176	1264	1525	1899	2254	2242	2756
3.35	1800	1074	1908	1640	2769	1835	3467	933	1544	1448	2276	1557	2754
	1500	1226	1869	1846	2716	2141	3399	1092	1564	1665	2303	1879	2802
	1200	1336	1812	1992	2637	2365	3298	1212	1561	1824	2297	2122	2806
	1000	1383	1732	2050	2524	2462	3147	1266	1522	1893	2240	2234	2736
3.55	1800	1197	1991	1431	2509	1617	3177	1062	1644	1247	2038	1351	2495
	1500	1326	1938	1622	2453	1900	3103	1199	1648	1449	2058	1651	2532
	1200	1416	1870	1759	2374	2109	3000	1298	1630	1599	2050	1877	2531
	1000	1450	1783	1815	2267	2200	2854	1340	1584	1664	1996	1982	2462
3.75	1800	1182	1937	1420	2455	1620	3121	1054	1607	1244	2003	1365	2465
	1500	1295	1876	1594	2391	1879	3036	1174	1600	1428	2013	1639	2487
	1200	1372	1802	1716	2307	2067	2925	1260	1575	1563	1996	1844	2473
	1000	1399	1714	1765	2198	2148	2777	1294	1525	1621	1939	1938	2400
4	1800	1145	1871	1380	2376	1577	3023	1022	1554	1211	1941	1331	2391
	1500	1251	1810	1543	2311	1821	2935	1135	1545	1384	1947	1590	2407
	1200	1322	1736	1658	2226	1998	2823	1215	1518	1510	1927	1784	2388
	1000	1347	1650	1703	2119	2073	2678	1246	1468	1564	1869	1871	2315
4.5	1800	1271	2041	1504	2517	1703	3106	1140	1705	1331	2074	1464	2493
	1500	1374	1967	1650	2431	1904	2985	1251	1686	1488	2061	1679	2472
	1200	1442	1881	1751	2329	2044	2844	1327	1650	1600	2024	1835	2423
	1000	1464	1786	1787	2211	2098	2685	1357	1593	1646	1957	1902	2333
5	1800	1316	2063	1626	2642	1842	3269	1189	1737	1453	2198	1599	2646
	1500	1399	1975	1751	2533	2025	3126	1280	1702	1588	2162	1796	2603
	1200	1451	1877	1832	2411	2150	2966	1341	1653	1681	2106	1938	2536
	1000	1465	1776	1857	2282	2195	2793	1361	1589	1715	2027	1996	2434

Notes: Coolant spec requirements: Temp 20°C, Flow rate: 5 liter/min.

Dimension Table

Dimension Table

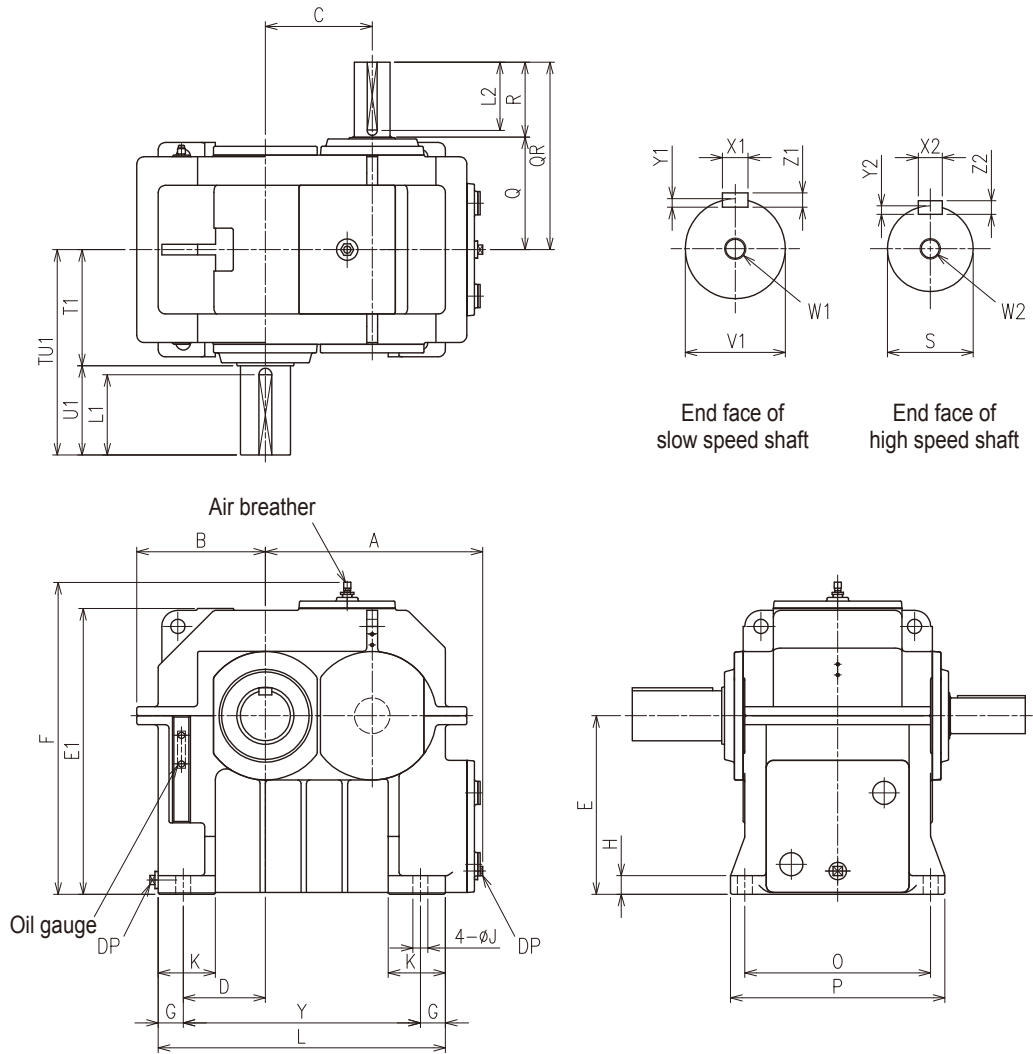

Size	A	B	C	D	E	E1	F	G	H	J	K	L	O	P	Y
060	542	330	262	200	450	715	789	70	45	35	150	707	430	510	567
070	609	360	299	230	500	800	874	70	52	42	160	804	520	600	664
080	656	395	341	265	560	895	969	70	52	42	160	886	570	650	746

Size	High Speed Shaft										DP (Rp)	Approx. Weight (kg)	Approx. Oil Qty. (l)
	Q	QR	R	S	W2/Depth	Key							
						X2	Y2	Z2	L2				
060	280	450	170	90m6	M24/50	25	9	14	150	1 1/2"	710	75	
070	315	525	210	100m6	M24/50	28	10	16	190	1 1/2"	960	120	
080	340	550	210	110m6	M24/50	28	10	16	190	1 1/2"	1275	165	

Size	Slow Speed Shaft									
	TU1	T1	U1	V1	W1/Depth	Key				
						X1	Y1	Z1	L1	
060	540	290	250	130m6	M24/50	32	11	18	225	
070	575	325	250	140m6	M30/60	36	12	20	225	
080	600	350	250	150m6	M30/60	36	12	20	225	

Dimension Table (Cooling Fan, Cooling Coil Inlet/Outlet)

Dimension Table (Cooling Fan, Cooling Coil Inlet/Outlet)

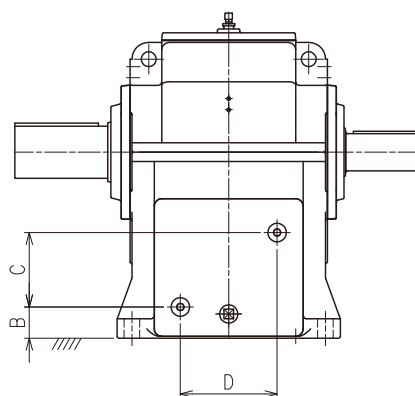
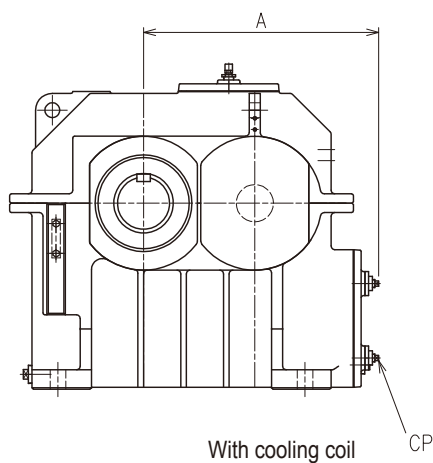
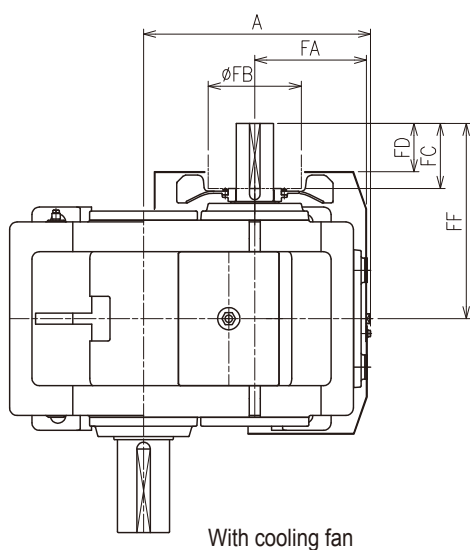

Size	Cooling Fan						Cooling Coil				
	A	FA	FB	FC	FD	FF	A	B	C	D	CP (Rp)
060	543	270	250	135	90	450	565	65	200	200	1/2"
070	610	300	250	175	130	525	632	84	200	260	1/2"
080	657	305	250	175	130	550	679	105	200	310	1/2"

Warranty and Warning

Warranty

Warranty Period	The warranty period for the Products shall be 18 months after the commencement of delivery or 18 months after the shipment of the Products from the seller's works or 12 months from the Products coming into operation, whichever comes first.
Warranty Condition	<p>In case that any problems, troubles or damages on the Products arise due to the defects in the Products during the above "Warranty Period", although the Products are appropriately and properly installed in, connected or combined to the equipment or machines, or maintained in accordance with the maintenance manual and are properly operated under the conditions as described in the catalogue or otherwise as agreed upon in writing between the Seller and the Buyer or its customers, the Seller will Provide, at its sole discretion, appropriate repair or replacement on the Products free of charge, except as stipulated in the "Exception for Warranty" as described below.</p> <p>However, in the event that the Products is installed in, connected or combined to or integrated into the equipment or machines, the Seller shall not reimburse the costs for removal or re-installation of the Products or other incidental costs related thereto and any lost opportunity, loss of profit or any other incidental or consequential losses or damages incurred by the Buyer or its customers.</p>
Exception for Warranty	<p>Notwithstanding the above warranty, the warranty as set forth herein shall not be applied to the problems, troubles or damages on the Products which are caused by:</p> <ol style="list-style-type: none"> 1. installations, connections, combinations or integration of the Products in or to the other equipment or machines, which are rendered by any person or entity other than the Seller, 2. the insufficient maintenance or improper operation by the Buyer or its customers, such that the Product is not appropriately maintained in accordance with the maintenance manual provided or designated by the Seller, 3. the improper use or operation of the Products by the Buyer or its customers which are not informed to the Seller, including, without limitation, the Buyer's or its customers' operation of the Products not in conformity with the specifications, or use of the lubrication oil in the Products which is not recommended by the Seller, 4. troubles, problems or damages on any equipment or machines in or to which the Products are installed, connected or combined or installed, or any specifications particular to the Buyer or its customer.

SAFETY PRECAUTIONS

- Strictly observe the safety rules for installation place and equipment to use. (Industrial Safety and Health Law, Technical Standard for Electric Facilities, Extension Rules, Plant Explosion Guidelines, Building Standards Law, etc.).
- Carefully read the maintenance manual before use. If the maintenance manual is not on hand, make a request for one to the distributor at which you purchased the product or to our sales department. The maintenance manual should be sent to the actual user.
- Select an appropriate product that matches the operating environment and usage.
- Install a protective equipment on the machine side when the machine is used for transportation of passengers or for elevators, escalators, and dumbwaiters.
- When the machine is used for food processing equipment and others that are susceptible to oil, install an oil pan or other damage preventive devices in case of oil leakage due to failure or termination of service life.

Worldwide Sumitomo Network

U.S.A.

Sumitomo Machinery Corporation of America (SMA)
4200 Holland Blvd.
Chesapeake, VA 23323,
U.S.A.
Tel: (1) 757-485-8218
Fax: (1) 757-485-7490

Argentina

SM-Cyclo de Argentina S.A. (SMAR)
Montes de Oca #6719, (B1606BMG) Munro,
Buenos Aires, Argentina
Tel: (54) 11-4765-5332
Fax: (54) 11-4765-5517

Brazil

SM-Cyclo Redutores do Brasil, Ltda. (SMBR)
Av. Fagundes Filho, 191 Metro Sao Judas
Edificio Houston-Sala H123 Sao Paulo-SP
Brasil 04304-010
Tel: (55) 11-5585-3600
Fax: (55) 11-5585-9990

Chile

SM-Cyclo de Chile, Ltda. (SMCH)
San Pablo Ave, 3507 Quinta Nomal,
Santiago, Chile
Tel: (56) 2-892-7000
Fax: (56) 2-892-7001

Mexico

SM-Cyclo de Mexico, S.A. de C.V. (SMME)
Calle "C" No. 506A Parque Industrial
Almacentro Apodaca, N. L., Mexico 66600
Tel: (52) 81-8144-5130
Fax: (52) 81-8369-3699

Canada

SM-Cyclo of Canada, Ltd. (SMC)
1045 South Service Road West,
Oakville, Ontario,
Canada L6L 6K3
Tel: (1) 905-469-1050
Fax: (1) 905-469-1055

Germany

Sumitomo (SHI) Cyclo Drive Germany GmbH (SCG)
Cydostraße 92, 85229 Markt Indersdorf,
Germany
Tel: (49) 8136-66-0
Fax: (49) 8136-5771

Austria

SCG Branch Austria Office
Gruentalerstraße 30A, 4020 Linz,
Austria
Tel: (43) 732-330958
Fax: (43) 732-331978

Benelux

SCG Branch Benelux Office
Office Heikneuterlaan 23, 3010
Kessel-Lo/Leuven, Belgium
Tel: (32) 16 60 83 11
Fax: (32) 16 57 16 39

France

SM-Cyclo France E.U.R.L. (SMFR)
65-75 Avenue Jean Mermoz, Espace Primagaz,
93126 La Courmeuve, France
Tel: (33) 149-929494
Fax: (33) 149-929490

Italy

SM-Cyclo Italy Srl (SMIT)
Via dell' Artigianato 23, 20010
Cornaredo (MI), Italy
Tel: (39) 02-9356-2121
Fax: (39) 02-9356-9893

Spain

SM-Cyclo Iberia, S.L. (SMIB)
Edificio Gobelas, C/Landabarrí, nº 4
Escalera 1, 2º Izqda, Leioa 48940
Vizcaya, Spain
Tel: (34) 944-805389
Fax: (34) 944-801550

Sweden

SM-Cyclo Scandinavia AB (SMSC)
Ridbanegatan 4, S-21377 Malmö,
Sweden
Tel: (46) 40220030
Fax: (46) 40220035

UK

SM-Cyclo UK Ltd. (SMUK)
Unit 29, Bergen Way,
Sutton Fields Industrial Estate,
Kingston upon Hull,
HU7 0YQ, East Yorkshire,
United Kingdom
Tel: (44) 1482-790340
Fax: (44) 1482-790321

China

Sumitomo (SHI) Cyclo Drive China, Ltd. (SCT)
13 Floor, No. 1698 Yishan Rd,
Shanghai, China 201103
Tel: (86) 21-3462-7877
Fax: (86) 21-3462-7922

Hong Kong

SM-Cyclo of Hong Kong Co., Ltd. (SMHK)
Unit 1802, 18/F, Park Building,
476 Castle Peak Road, Kowloon,
Hong Kong
Tel: (852) 2460-1881
Fax: (852) 2460-1882

Korea

Sumitomo(SHI) Cyclo Drive Korea, Ltd. (SCK)
Royal Bldg. 9F Rm. 913,
5 Danju-Dong, Chongro-ku,
Seoul, Korea 110-721
Tel: (82) 2-730-0151
Fax: (82) 2-730-0156

Taiwan

Tatung SM-Cyclo Co., Ltd. (TSC)
22 Chungshan N. Road
3rd., Sec. Taipei, Taiwan 104, R.O.C.
Tel: (886) 2-2595-7275
Fax: (886) 2-2595-5594

Singapore

Sumitomo (SHI) Cyclo Drive Asia Pacific Pte. Ltd. (SCA)
15 Kwong Min Road,
Shingapore 628718
Tel: (65) 6591-7800
Fax: (65) 6863-4238

Philippines

SCA Branch Office in Philippines
B2b Granville Industrial Complex,
Governor's Drive, Bo, Bancal,
Carmona 4116 Cavite, Philippines
Tel: (63) 2-6800-6500
Fax: (63) 2-6800-6555

Vietnam

SCA Representative Office in Ho Chi Minh
Floor 4, 99 Nguyen Thi Minh khai Street
World Ben Thanh, District 1, HCM,
Vietnam
Tel: (84) 8-3925-6504
Fax: (84) 8-3925-6505

Malaysia

SM-Cyclo (Malaysia) Sdn. Bhd. (SMMA)
No.2, Jalan BP 4/1,
Bandar Bukit Puchong, 47100 Puchong,
Selangor Darul Ehsan,
Malaysia
Tel: (60) 3-8061-2909
Fax: (60) 3-8061-3909

Thailand

SM-Cyclo (Thailand) Co., Ltd. (SMTH)
195, Empire Tower 21st FL.,
Unit 2103-4, South Sathorn Road,
Yannawa Sathorn Bangkok 10120,
Thailand
Tel: (66) 2-670-0998
Fax: (66) 2-670-0999

Australia

SM-Cyclo (Australia) Pty., Ltd. (SMAU)
9 Holbeche Rd,
Ardell Park, NSW, 2148,
Australia
Tel: (61) 2-8811-6555
Fax: (61) 2-8811-6500

India

Sumi-Cyclo Drive India Private Limited
Survey No. 130, Hissa No. 02, Jeevan Nagar
Next to TVS Logistics,
Off Mumbai-Bangalore bypass,
Tathawade, Pune-411 033,
India
Tel: (91) 20-6674-2900
Fax: (91) 20-6674-2901

Japan

Sumitomo Heavy Industries, Ltd.
ThinkPark Tower, 1-1, Osaki 2-Chome,
Shinagawa-ku, Tokyo 141-6025,
Japan
Tel: (81) 3-6737-2511
Fax: (81) 3-6866-5160